

Vol. 16 No. 2

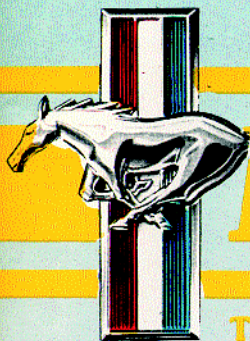

MUSTANG TIMES

The Official Publication of The Mustang Club of America

February 1992

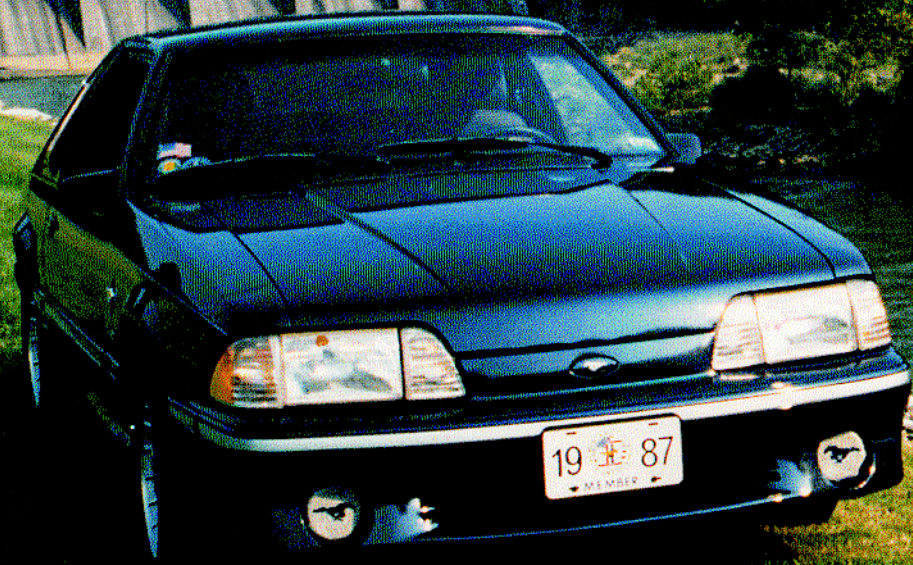

Does Your Carburetor Run Properly & Look Like This?

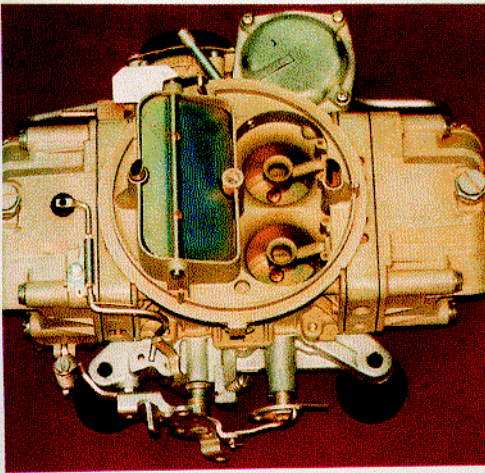

HOLLEY 4150

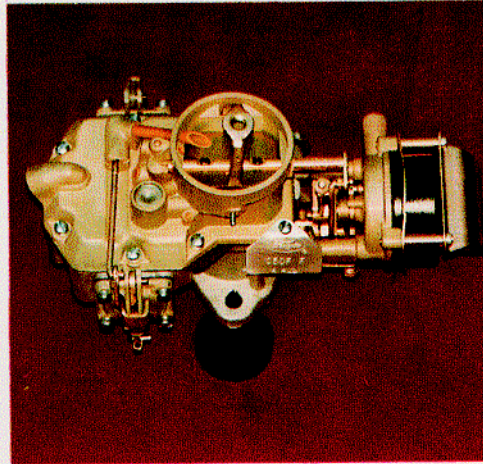

AUTOLITE 1100

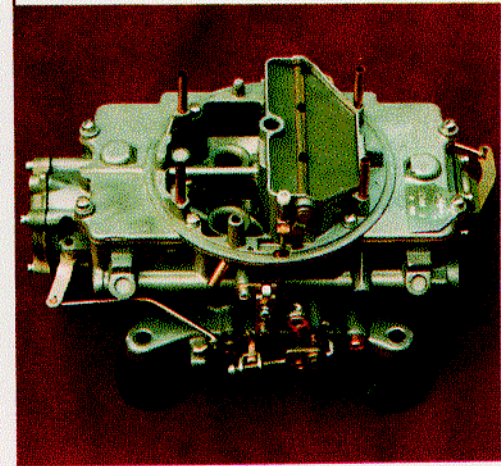

AUTOLITE 4100 "HI-PO"

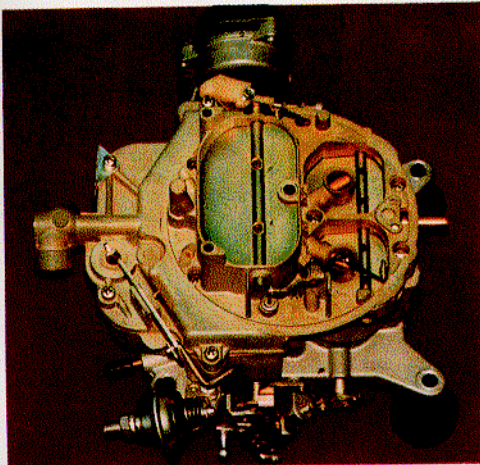

AUTOLITE 4300

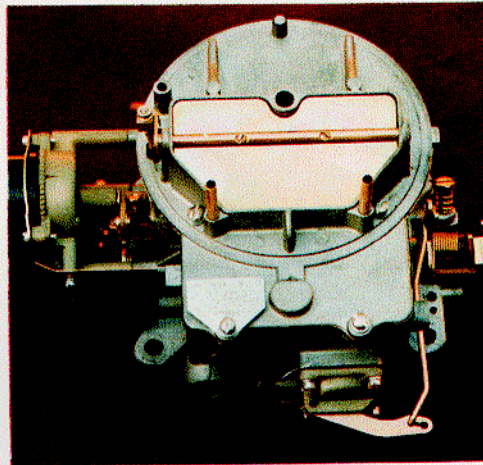

AUTOLITE 2100

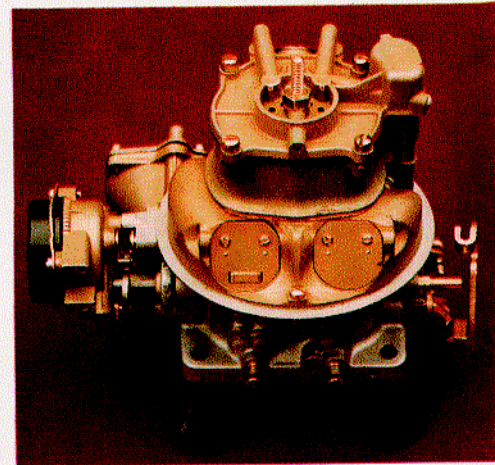

HOLLEY 4000 "TEAPOT"

FORD CARBURETOR REBUILD AND RESTORATION SPECIALISTS

- We will rebuild yours or you may purchase our core (hundreds of cores in stock - some very rare)
- Concours plating; show quality: standard restoration (non-plated) also available.
- Ford Autolite 1100 I-V Performance engineered to overcome original factory problems.
- Ford Autolite 2100-2V, 4100-4V, 4300-4V calibrated and engineered for your specific application with performance enhancement.
- Holley Performance experts. HI-PO specialists.
- All carburetors run tested and adjusted on engine before shipping.
- Competitive pricing / extraordinary quality.

Also available:

- 6 cylinder performance kits; includes parts, complete explanation, instructions and diagrams (\$18.00 plus shipping)
- Reproduction carburetor tags; FoMoCo and Autolite series; order by application or your tag no. (\$10).



PONY CARBURETORS, INC.



Box 420, 74 Lincklaen St., Cazenovia, NY 13035
315-655-4466



MUSTANG TIMES

\$3.00

Est

The Mustang Club of America

1964 1/2



1992

FROM
NATIONAL HEADQUARTERS
THE MUSTANG CLUB OF AMERICA, INC.
P.O. BOX 447
LITHONIA, GEORGIA 30058
(404) 482-4822 (9 AM - 1 PM)

FOR ADDRESS CHANGES

Please allow at least six weeks for change of address and enclose old address as well as new address, including, if possible, an address label from a recent issue. Send change to address at left.



Founded - 1976

DATED MATERIAL

Second Class
Postage
PAID
Lithonia, GA
30058

All Mustangs 1965-70 Shelbys

... the most exciting American sports cars

**NOW THERE'S AN INTERNATIONAL CLUB FOR OWNERS OF THESE
SUPERB AUTOMOBILES. WE'D LIKE TO TELL YOU ABOUT IT.**

It's called the Mustang Club of America, and you'll find representative members through the United States and Canada... even in some foreign lands.

Why a Mustang Club?

MCA was formed to band together owners of this classic automobile... to provide a medium of exchange for ideas, technical information, amusing reminiscences, and the purchase of parts — often at substantial discount. Lasting friendships have been formed through regional get-togethers and as a result of the Club's national meets.

Prized Possession

Mustangs and Shelbys are greatly in demand these days, and a good one is rarely offered for sale because discriminating owners realize they possess an automobile of advanced design and beauty, one that will retain its saucy, modern appearance for years to come with a little loving care. These people have insight and sound judgment, and the Mustang Club of America wants to help them preserve their little cars.

For many such judicious and intelligent folks the savings in time and money in parts location alone have been reason enough for being members of our growing institution. Some dote on tech tips, while for others, the camaraderie that exists between persons of like tastes is their compelling reason for belonging to the Mustang Club of America.

What Membership Means

Whether your Mustang or Shelby serves as everyday transportation, a relaxing plaything, or both, you'll find valuable help in your restoration and maintenance problems in the Tech Tips printed in the club publication, the MUSTANG TIMES. This informative, illustrated periodical is distributed every month, and contains many interesting features besides the mechanical information mentioned... articles

Enroll-A-New-Member — TODAY! —

about member cars, news of chapter events and activities, all profusely illustrated with photos, diagrams and cartoons. In addition, the MUSTANG TIMES offers an advertising service to those wishing to buy, sell or swap parts or cars.

Tours, meets, rallies, picnics, camp-outs and other outings designed to encourage group participation (with the Mustang or Shelby, that is) are regularly conducted by the various chapter groups located throughout the United States and Canada. There is probably one near you! You are warmly invited to attend any of these friendly chapter meetings or events.

Who Belongs?

MCA boasts people of all ages — from those born before the Turn of the Century to teen-agers still in school. Among the members are professional men and women — doctors, dentists, lawyers — individuals who could certainly afford newer, more costly vehicles if they chose. Widows, widowers, single persons and married all find something of value in their memberships, for the pride of owning the Classic Mustangs and Shelbys, the exclusive personal car of distinction, keeps them driving a vehicle of a past and present decade. For this company of people, there's a whole of a lot of fun in driving a Mustang or Shelby. To them it's a daily holiday, a pick-me-up that never lets them down. It's full expression of their love of life and the chance to live the life they love. MCA wants to keep them that way.

Premium Packet

Every new member receives a new member packet upon payment of initiation fee and dues. Also, many items such as patches, hats, decals, etc. are sold to members *only* at substantial savings.

MCA Hotline 404-482-4822

Monday - Friday 9 a.m. - 1 p.m. (E.S.T.)

**OUR OBJECTIVE: EVERY MUSTANG AND SHELBY
OWNER A MCA MEMBER
APPLICATION BLANK BELOW**

PLEASE ALLOW 6 WEEKS DELIVERY OF FIRST ISSUE

CUT ALONG THIS LINE



Founded 1976

MEMBERSHIP APPLICATION

YES!!! I want to join the most responsive and fastest growing organization in the world dedicated to the preservation, care, history and enjoyment of all year Mustangs — 1965-1970 Shelbys. Enclosed is \$25.00 U.S./\$30.00 Canada (U.S. Funds)/\$50.00 Foreign (U.S. Funds).

Please send my new member's packet immediately and the next 12 issues of *The Mustang Times*.

NATIONAL HEADQUARTERS • P.O. BOX 447 • LITHONIA, GEORGIA 30058-0447

Name _____ Spouse _____

Address _____

City _____ State _____ Zip _____

Please Type, Print or Affix Address Label

OWNERSHIP NOT ESSENTIAL

ENTHUSIASM IS

FROM NATIONAL HEADQUARTERS

THE MUSTANG CLUB OF AMERICA

P.O. BOX 447 LITHONIA, GEORGIA 30058 404-482-4822 (9 AM - 1 PM Mon.-Fri. e.s.t.)

MCA 1992 Wall Calendar	\$10.00
MCA Windshield Decal	\$ 1.00
MCA 3" Cloth Emblem	\$ 2.50
MCA Official Mustang II Judging Rule Book	\$ 3.00
MCA Official 1964½-73 Judging Rule Book	\$ 3.00
MCA Jacket* (100% Nylon w/Shell Lining, Black, Red, Royal Blue)	\$32.00
MCA T-Shirt* (Black, Red, Blue)	\$ 8.95
MCA Caps	\$ 5.50
Tags (State Year of Car)	\$ 4.50

*State Size And Color When Ordering
Add \$1.50 Postage And Handling For Shirts, Caps & Tags.



Send check/money order to:
MCA Accessories
P.O. Box 447
Lithonia, Georgia 30058-0447

Old Address		New Address	
Name _____	Name _____	_____	_____
Address _____	Address _____	_____	_____
Membership No. _____			
(Membership number from membership card.)		Mail to: Mustang Times P.O. Box 447 Lithonia, GA 30058	

MOVING?
Allow 6 to 8 weeks
for processing.

CONDON & SKELLY

Antique, Classic, Special Interest, Postwar
& Milestone Motorcar Insurance.

including:
SPARE PARTS
COVERAGE AT NO
ADDITIONAL
PREMIUM

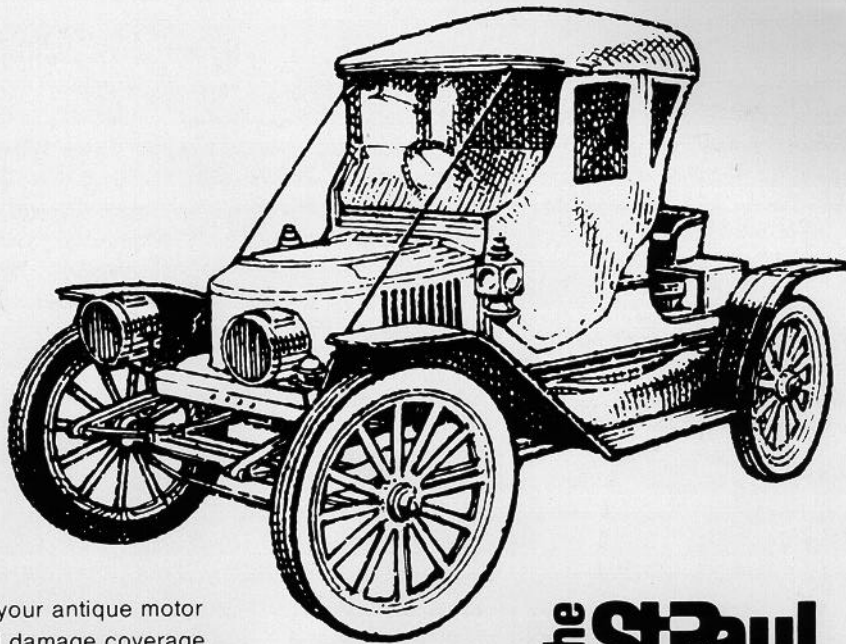

Now when you insure your antique motor cars including physical damage coverage, we add \$250 spare parts coverage at no additional premium.

The St. Paul Mercury Insurance Company, which underwrites this policy, offers this coverage as part of their regular policy. And no wonder. The St. Paul has been a leader in innovative insurance since 1853.

Along with increased coverage, our new policy also gives you these other advantages. High limit of liability and medical payments coverage. Low premium rates. And if your state requires "No-Fault" or "Uninsured Motorist" coverage, we'll add it automatically, with premium adjustment made at the time of policy issuance.

The St Paul
Property & Liability
Insurance

You also get prompt service. Policies are issued upon receipt of application and payment.

Should your beautiful motor car suffer any damage, you can be assured of fast, fair claim service. Just contact one of The St. Paul's coast-to-coast claim offices or Condon & Skelly.

For more information, please contact

Condon & Skelly
Antique Motor Car
Insurance Brokers
Suite 203
121 East Kings Hwy.
Maple Shade, NJ 08052
(609) 234-3434



Nationwide 1-800-257-9496 In NJ 1-800-624-4688

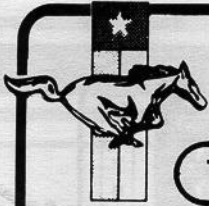

Texas Mustang Parts

THE COMPANY THAT GUARANTEES YOUR SATISFACTION & ITS SERVICE

WE CARRY A FULL LINE OF OVER 4000 GENUINE FORD AND QUALITY REPRODUCTION 1965-73 MUSTANG PARTS IN STOCK

- *Upholstery
- *All Interior Items
- *Under Hood Items
- *Clutch & Brake
- *Electrical
- *Weatherstrip
- *Exterior Items
- *Differential Items
- *Convertible Tops
- *Windshields
- *Audio
- *Suspension
- *Sheetmetal
- *Decals
- *Wiring
- *Literature
- *Moulding
- *Bumpers
- *AC Parts



1965-1973 Classic Mustang Parts and Accessories

PLUS MANY MORE ITEMS!

Call our CATALOG REQUEST NUMBER 1-817-662-2793 or write for your **NEW FREE CATALOG** of 146 pages and over 675 pictures of **GENUINE FORD** and **TOP QUALITY REPRODUCTION PARTS** along with illustrations, code tables, & paint codes for your 1965-73 Mustang. **HAS YOUR MAILING ADDRESS CHANGED?** Please notify us so you will continue to receive our Catalog plus any special announcements.

Along with our guaranteed satisfaction policy, **TEXAS MUSTANG PARTS** provides the following services:

- * **FREE** Catalog
- * **FREE Toll Calls** for orders
- * **FREE SHIPPING** on orders over \$150 in continental USA if UPS acceptable
- * **LARGE PURCHASE DISCOUNTS**
- * **SAME DAY SHIPPING** on most orders, all within 36 hours or we will notify you
- * **GENUINE FORD & TOP QUALITY REPRODUCTION PARTS** separated by part numbers
- * **MONEY BACK GUARANTEE** on unused merchandise purchased from us.

Combine the above services with our **quality merchandise, low prices, and quick courteous service** and you will find out why **"WE ARE ONE OF THE FASTEST GROWING MUSTANG DEALERS IN THE USA."**

NEW WINDSHIELDS
Shaded Top with Tinted Bottom
FREE DELIVERY IN CONTINENTAL USA

1965-67 All	140.00
1968 All	140.00
1969/70 Cp/Cv	180.00
1969/70 Fb	200.00
1971-73 Cp/Cv	200.00
1971-73 Fb	230.00

Alaska Add 20.00
Hawaii Add 53.00

FINEST AUTHENTIC MUSTANG UPHOLSTERY AVAILABLE

1965-69 STANDARD SETS
Two Buckets & Rear 149.95
Two Buckets 105.95

1970-73 STANDARD SETS
Two Buckets & Rear 189.95
Two Buckets 125.95

1965/66 DELUXE PONY SETS
Two Buckets & Rear 199.95
Two Buckets 129.95

1969-73 DELUXE/MACH1/SHELBY
Two Buckets & Rear 249.95
Two Buckets 165.95

MOULDED CARPET
The most original moulded carpet available with the correct heel & toe plates, padding, & serge or vinyl bound edges.

80/20 Rayon/Nylon Blend
1965-68 88.00
1965-68 Folddown 15.00

100% Nylon Blend
1969-73 88.00
1969-73 Folddown 15.00

MACH I
1969/70 160.00
1971-73 Pony Insert 160.00
1969-73 Folddown 15.00

ARM REST PADS & BASES

1965/66 Arm Rest Pad	ea. 9.50
1965/66 Chrome Base	ea. 7.50
1967 Arm Rest	ea. 21.95
1968 Arm Rest	ea. 28.95
1969/70 Arm Rest	ea. 33.95
1971-73 Arm Rest	ea. 26.95

6 YEAR CONVERTIBLE TOPS

1965-73 W/Vinyl Curtain	
Black or White	134.95
1965-73 W/Glass Curtain	
Black or White	224.95
1965-70 Original Type	
Webb Pads 4 Pc.	49.50

WEATHERSTRIP

1965-68 Conv Top Kit	5-pc. kit 100.00
1965/66 Door to Body	pr. 21.95
1967/68 Door to Body	pr. 26.95
1969/70 Door to Body	pr. 44.95
1965-68 Cp Roof Rail	pr. 31.95
1965-68 FB Roof Rail	pr. 52.95

GLASS GASKETS

1965-68 Windshield	25.95
1965-68 Coupe Rear Glass	25.95
1965/66 FB Rear Glass	25.95
1967/68 FB Rear Glass	34.95
1969-73 FB Rear Glass	39.95
1969-73 Coupe Rear Glass	39.95

STANDARD DOOR PANELS
New panels in all colors from our upholstery manufacturer. Exact match in grain & color.

1965-69	pr. 64.00
1970	pr. 79.00
1971-73	pr. 84.00

OTHER DOOR PANELS

1965/66 Pony WO/Chrome	pr. 134.95
1967 Deluxe WO/Chrome	pr. 179.95
1968 Deluxe Woodgrain	pr. 135.00

HEAVY DUTY KICK PANELS

1965-68 CP/CV/FB	pr. 22.95
------------------------	-----------

FOR 1964 1/2 MUSTANGS

NEW STEERING WHEEL

call for details

Black	158.20
Colors	203.20

ORDER TOLL FREE IN TEXAS AND U.S.A.
1-800-527-1588

CATALOG REQUEST NUMBER
1-817-662-2793

FAX # 1-817-662-0455
INFORMATION: 1-817-662-2893

Texas Mustang Parts

Rt. 6, Box 996A Waco, Texas 76706
STORE HOURS:
Mon.-Fri. 8-5:30, Sat. 8-12 Central Time
We Accept Visa-MasterCard-COD-Money Order
Prices subject to change without prior notice
Texas Residents Add 6 1/2 % Sales Tax.

COMPARE OUR PRICES on the **BEST QUALITY PARTS** available to other dealer's prices and add the **FREIGHT** and **TELEPHONE** charges to their total price and you will find doing business with **TEXAS MUSTANG PARTS** will usually cost less. Plus our **LARGE PURCHASE DISCOUNT PLAN** will save you even more money.

MUSTANGS

unlimited



185 ADAMS STREET
MANCHESTER, CT 06040

QUALITY PARTS AND SERVICE

Ford MOTORSPORT AUTHORIZED
PERFORMANCE EQUIPMENT DISTRIBUTOR



Monday-Friday: 8:30 to 5:30
Thursday: 8:30 to 8:00 Saturday: 8:30 to 3:00

SHOW SCHEDULE

Jan. 18-19
West Springfield, MA
Feb. 14-16
Atlantic City, NJ
Feb. 23
Hartford Civic Center, CT
Free Delivery to Shows!



Catalog \$4⁰⁰

M
T
7
9
1

(203) 647-1965 • ORDER TOLL-FREE: 1-800-243-7278 • FAX: (203) 649-1260

GT FOG LAMP KITS

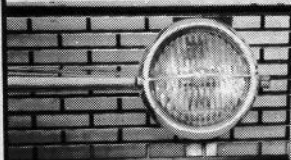

Kit includes housings, bulbs and grille bars.

68390 '65-66 models \$169⁹⁵ kit
78390 '67 models \$215⁰⁰ kit

CHROME BUMPERS

'65-68 front or rear \$77⁹⁵ ea
'69-70 front or rear \$84⁹⁵ ea

Triple chrome plating...
Best reproductions available!

BUMPER KITS

Front bumper, brackets, guards and bolts.
57757KIT '65-66 models \$155⁹⁵ kit
77757KIT '67-68 models \$155⁹⁵ kit
Rear bumper, guards and bolts.
57906KIT '65-66 models \$115⁹⁵ kit
77906KIT '67-68 models \$115⁹⁵ kit

KYB SHOCK Gas-a-just ABSORBERS

'65-73 models - set of 4 \$99⁹⁵ set

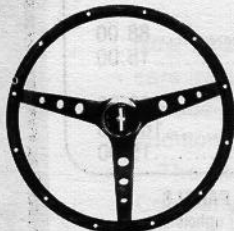

MUSTANG STEERING WHEEL

Real walnut wood!
Includes mounting kit.

\$79⁹⁵

966A '64-1/2
966B '65-67
966C '68-73



TRI-Y HEADERS

S1MS9430R

Includes collectors, flanges, gaskets and hardware.

\$109⁹⁵ set

1965-68 Small Block DUAL EXHAUST

Completely Aluminized kit includes H-pipe

C5ZZ5257ERK \$159⁹⁵ kit

1970-73 models DUAL EXHAUST

Aluminized kit features 2-1/4" pipes & mufflers.

H-pipe sold separately. \$189⁹⁵ kit

MOLDED CARPETING

Meets OEM specifications... all colors avail.
'65-73: specify year & body style \$84⁹⁵
MACH I w/inserts \$145⁰⁰
Fold down pieces for fastback \$15⁰⁰
Underlayment Kits starting at: \$34⁹⁵
'74-91 Mustang carpet \$99⁹⁵

FLOOR MATS

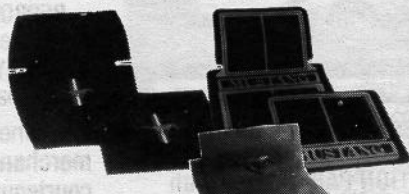

Tri-color w/horse

(set of 4) \$27⁹⁰

2-tone carpeted w/logo

(set of 4) \$34⁹⁵

Original type PONY mats (set of 4)

Black \$39⁹⁵ Other colors \$45⁰⁰

CHOOSE FROM 3 CATALOGS

- '65-73 MUSTANG & SHELBY catalog only \$3⁹⁹
- '74-91 MUSTANG catalog only \$2⁹⁹
- '67-73 COUGAR catalog only \$2⁹⁹



Late Mustang Catalogs FREE with Order Cougar



SEAT COVERS

Others seat covers available.
For a complete listing see our catalog!

'65-68 standard buckets \$99⁹⁵ pr
Complete set \$149⁹⁵ set
Complete PONY set \$204⁹⁵ set
'69-70 MACH I buckets \$159⁹⁵ pr
Complete set \$239⁹⁵ set

DOOR PANELS



'65-68 standard interior \$54⁹⁵ pr
'69-73 standard interior \$79⁹⁵ pr
'65-66 PONY interior \$115⁹⁵ pr
'69-73 Deluxe starting at: \$289⁹⁵ pr
'69-73 Deluxe skins (most colors) \$249⁹⁵ pr

BODY PANELS



> Hood - '65-66 \$149⁹⁵; 67-68 w/o ind. \$159⁹⁵; > Fender - '65-66 \$129⁹⁵; '67-68 \$129⁹⁵; '69-70 \$139⁹⁵; > Quarter Panel - '65-66 Coupe/Conv \$129⁹⁵; > Quarter Panel Skin - '65-68 \$79⁹⁵; '69-70 Coupe/Conv \$119⁹⁵; FB \$99⁹⁵; '71-73 \$99⁹⁵; > Front Valance - '65-68 \$34⁹⁵; '69-70 \$69⁹⁵; > Rear Valance - '65-68 \$34⁹⁵; '69-70 \$44⁹⁵; '71-73 \$54⁹⁵; > Decklid - '65-66 \$149⁹⁵; > Tail Lamp Panel - '65-68 \$49⁹⁵; '69 \$92⁵⁰; '70 \$79⁹⁵; '71-73 \$99⁹⁵

FLOOR PANS



FULL LENGTH - 60" x 24" \$69⁹⁵ ea
SHORT FRONT - 22-1/2" x 24" \$29⁹⁵ ea
LONG FRONT - 38-3/4" x 24" \$39⁰⁰ ea
LONG REAR - 34" x 24" \$44⁰⁰ ea
SHORT REAR - 20" x 24" \$39⁰⁰ ea
FIREWALL PATCH - 18" x 22" \$34⁹⁵ ea



CAR COVERS

Prices starting at:
Polycotton \$72⁰⁰ Technalon \$99⁹⁵
Flannel-lined \$99⁹⁵ Cable Lock \$9⁹⁵



STYLED STEEL WHEELS

SET OF 4
C5ZZ1007SET '65 14 x 5" \$510⁰⁰
C6ZZ1007SET '66 14 x 5" \$415⁰⁰
C7ZZ1007SET '67 14 x 6" \$415⁰⁰
C5ZZ1130WR '65-66 centers \$17⁹⁵ ea
F1720 '67 centers \$16²⁵ ea
C5ZZ1210AR 14" trim rings \$64⁹⁵ set

MAGNUM 500 WHEELS

SET OF 4
D1OZ1007SET 14 x 7" \$650⁰⁰
D0ZZ1007SET 15 x 7" \$650⁰⁰
C9ZZ1007SET 15 x 8" \$650⁰⁰
C5ZZ1012BR Chrome Lugs \$2⁵⁰ ea
SHELBY 10-Spokes \$780⁰⁰ set

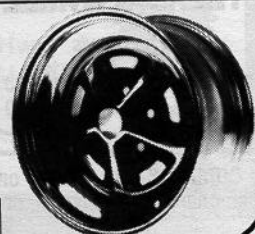

Mustang Club of America, Inc.

Official publication of
The Mustang Club of America, Inc.
P.O. Box 447
Lithonia, GA. 30058-0447
Publisher: Jack Yeager
Editor: Steve McMullan
Assistant Editor: Kitty Wilmot
Advertising Manager: Steve McMullan
For advertising information call (404)
535-1566 Monday through Friday.

National Headquarters Office:

Bill Koivu (404) 482-4822

National Regional Group Director:

Horace A. Wood
3653 Altadena Drive
Birmingham, AL. 35243
(205) 967-1705

National Head Judge:

Ricky Simmons
P.O. Box 387
Demorest, GA 30535
(404) 778-6329

National Show Director:

Jim Watson
307 Southfork Court
Woodstock, GA 30188

For any correspondence pertaining to new membership, club information, renewals, national club business, or *The Mustang Times*, please address correspondence to National Headquarters address: The Mustang Club of America, Inc., P.O. Box 447, Lithonia, GA. 30058 or phone National Headquarters at (404) 482-4822 (9 a.m.-1 p.m. EST Monday through Friday). No collect calls, please!

Mustang Times (ISSN 0744-2572) is published monthly by the Mustang Club of America, Inc., 7138 Maddox Road, Lithonia, GA. 30058. Membership dues are \$25 per year, which includes \$20 for twelve monthly issues of *Mustang Times*. Second class postage paid at Lithonia, GA. 30058. Postmaster: please send address changes to *Mustang Times*, P.O. Box 447, Lithonia, GA. 30058.

It is requested that any transaction with the club, including dues payment, be made by check or money order payable to The Mustang Club of America. Cash must be sent at your own risk. Please notify the club of any change of address immediately and allow a minimum of six weeks for processing.

Mustang Times and The Mustang Club of America do not accept any responsibility for the accuracy of advertisements and/or advertisers. Any advertisers who have proved unreliable or who have been named in legitimate complaints from MCA members will not be allowed to advertise. Liability for clerical and/or typographical errors which may appear in *Mustang Times* is limited to the correction of same.

© 1992—Mustang Club of America

February, 1992

Vol. 16, No. 2



Twins Robert and Christian Anzalone may be a little young to drive daddy's Mustang, but father Robert says "it won't be long before they'll be wanting a Pony car of their own." In the meantime, these two young Mustangers are terrorizing the neighborhood with their '64½ pedal cars! Robert's MCA Membership Number is 23,166.

TABLE OF CONTENTS

MCA News & Notes	6-7
Directors' Page	9
Publisher's Column	11
Readers' Forum	12
MCA Notebook	17
Feature Car	20-21
February Cover Story	22-23
Regional News	24-28
Ask Fred	29
Late Model News	30-31
Gold Card Judges Listing	32-33
Troubleshooter	34-35
Welcome New Members	36
Horse Show	37
Calendar Of Events	38-39
Classified Ads	40-42

On The Cover

This 1987 Mustang GT, owned by Barbara Davenport of Port Neches, TX is her pride and joy — and her daily driver. The car was photographed by *Mustang Times* Editor Steve McMullan in Kingsport, TN last August. For the full story, see Pages 22-23 of this month's issue.



**Mustang Club Of America
1991 National Officers**

Bill Dillard President
 Jim Watson Vice President
 Kitty Wilmot Secretary
 Bill Koivu Treasurer
 Jack Yeager Publisher
 Ed Hunter Sergeant-at-Arms
 Max Craft Sergeant-at-Arms
 Ricky Simmons National Head Judge
 Bruce Weiss Asst. National Head Judge
 Horace Wood National Regional Group Director
 Jim Watson National Show Coordinator

**MCA National
Board of Directors**

Serving through January 1993

Max Craft (#15057) Winston, GA
 Sam Dean (#15793) Greenville, SC
 Junior Downer (#3370) Chattanooga, TN
 Tom Gattis (#252) Conyers, GA
 Charles Hampton (#1230) Anderson, SC
 E.G. Hardy (#14691) Hermitage, TN
 Ed Hunter (#447) Powder Springs, GA
 Mike Hollimon (#22497) Ringgold, GA
 Jim Johnson (#7547) Chattanooga, TN
 Lena Johnson (#7547) Chattanooga, TN
 Charles LaTaste (#17973) Oxford, AL
 Sue Osborn (#376) Buford, GA
 Amanda Perry (#13019) Kennesaw, GA
 Ricky Simmons (#17874) Demorest, GA
 Bob Vickery (#3411) Lithonia, GA
 Teresa Vickery (#3411) Lithonia, GA
 Horace Wood (#1821) Birmingham, AL

Serving through January 1994

Joe Antrican (#20749) Powell, TN
 Jo Ann Antrican (#20749) Powell, TN
 Jim Watson (#7506) Woodstock, GA
 Joe Charles (#23269) Calhoun, GA
 Randy Church (#17916) Baldwin, GA
 Bob Deale (#17160) Marietta, GA
 Pat Downer (#3370) Chattanooga, TN
 Bill Dillard (#7) Calhoun, GA
 Jack Hinson (#17428) Cartersville, GA
 Barbara Koivu (#758) Snellville, GA
 Bill Koivu (#758) Snellville, GA
 Tommy Gilstrap (#16647) Greenville, SC
 Jim Osborn (#376) Buford, GA
 Don Perry (#13019) Kennesaw, GA
 Walter Scott (#10395) Greenville, SC
 Bruce Weiss (#19423) Melbourne Beach, FL
 Kitty Wilmot (#5991) Roswell, GA
 Jack Yeager (#411) Decatur, GA

Honorary Members

Steve McMullan (#20044) Oakwood, GA

**December Meeting Minutes
Of MCA Board of Directors**

By SANDI DWARD
MCA National Secretary

The meeting of the Board of Directors of the Mustang Club of America was called to order by the president, Charles Hampton, Tuesday, Dec. 10, 1991.

Roll call was made with 30 directors responding.

Minutes of the November meeting were read and approved.

The treasurer's report was submitted for the month of November and approved.

Visitors were recognized and included Butch and Barbara Hollingsworth from the Northeast Georgia Regional Mustang Club and Russ Gilbert and Barry Hobgood from the Cherokee Regional Mustang Club.

OLD BUSINESS

Kitty Wilmot was appointed to be in charge of arrangements for the 1992 MCA Officers' Installation Dinner, to be held January 18.

A motion was made that the president send a letter to the Rainbeaux Mustang Club of Texas regarding infringement on Southeast Texas Regional Group's territory and informing the Rainbeaux Group that such infringement must stop at once or the club's charter would face revocation. This motion was approved.

Vintage Mustang Owners Association of California sent a letter to MCA. The letter was discussed by the board.

NEW BUSINESS

The election of 1992 officers was held. The results of the election were as follows:

President Bill Dillard
 Vice President Jim Watson
 Secretary Kitty Wilmot
 Treasurer William Koivu
 Sergeants-at-Arms Max Craft/Ed Hunter

With there being no further business, the meeting was adjourned. There was no meeting of the Board of Directors in January. That meeting was replaced by the annual installation of officers.

The next meeting of the Board of Directors of the Mustang Club of America will be held Tuesday, February 11, 1992, at the Marriott Courtyard Hotel at Windy Hill Road and I-85 in Marietta, GA, beginning at 7:30 p.m. The meeting is open to all dues-paying MCA members.

New National Head Judge Selected

Incoming MCA President Bill Dillard of Calhoun, GA has named Ricky Simmons of Demorest, GA to succeed Bob Perkins as MCA National Head Judge.

Simmons has served as MCA Assistant National Head Judge for the past year.

Bruce Weiss of Melbourne Beach, FL has been selected to replace Simmons as Assistant National Head Judge. Randy Church will continue to serve as an Assistant National Head Judge for late model classes.

In addition, Dillard has announced that newly-elected Vice President Jim Watson will now take over the duties of National Show Coordinator.

Watson will be in charge of accepting and assisting with the preparation of applications by MCA Regional Groups for sanctioned National and Grand National Shows. Groups interested in applying for MCA-sanctioned shows can contact him at MCA, P.O. Box 447, Lithonia, GA 30058.

Board Selects Bill Dillard '92 MCA National President

Bill Dillard of Calhoun, GA was elected National MCA President for 1992 by the Board of Directors at its December meeting.

Dillard will succeed Charles Hampton of Anderson, SC, who has served as MCA President for the past four years.

Dillard was Vice President and National Show Coordinator for MCA during 1991.



BILL DILLARD

He is also a former National Head Judge and long-time member of the board of directors.

Dillard, a charter member whose MCA Membership is 7, was one of the original founders of the national organization.

Jim Watson of Woodstock, GA was elected to serve as Vice President and National Show Coordinator for 1992.

Affiliated with State Farm Insurance in Dalton, Dillard is a member of the Cherokee Regional Mustang Club and is a past president of that MCA group. He also served three years as National Head Judge for MCA.

His wife, Sandi, served as National MCA Secretary during 1991.

Dillard joined the MCA Board of Directors in 1978. He and Sandi owned two Mustangs, a 1969 convertible and a 1989 convertible. The couple has two children, Brandon, 9, and Leanne, 6.

Kitty Wilmot of Roswell, GA was elected

secretary during the December board meeting. She has held that position previously and is also Assistant Editor of *The Mustang Times*.

Bill Koivu of Snellville, GA, long-time MCA treasurer, was re-elected to his post for 1992. Koivu also serves as office manager for the national organization.

Max Craft of Winston, GA and Ed Hunter of Powder Springs, GA were elected sergeants-at-arms.

In addition, Jack Yeager of Decatur, GA will continue to serve as Publisher of *The Mustang Times*.

Dillard has also announced the appointment of Ricky Simmons of Demorest, GA as MCA National Head Judge for 1992. He succeeds Bob Perkins of Juneau, WI. Simmons served as Assistant National Head Judge in 1991.

Bruce Weiss of Melbourne Beach, FL has been appointed Assistant National Head Judge for 1992.

All MCA officers are elected annually at the December meeting of the organization's national board of directors.

Nominees are selected by a committee composed of board members, but nominations are also taken from the floor.

Officers are installed at a banquet held each January.

The 1992 Officers' Installation Banquet was held Saturday, Jan. 18 at Days Inn North in Atlanta.

Coverage of the installation banquet will be included in the March issue.

MCA 1993 Show Applications Due In March, April

Deadlines for MCA Regional Groups desiring to sponsor 1993 National and Grand National shows are now only weeks away.

The deadline for applications for the 1993 Grand National is March 1, so only a few days remain for groups to submit their paperwork to MCA for consideration as sponsors of that event.

The deadline for applications for 1993 MCA-sanctioned national shows is April 1.

Jim Watson, elected in December as vice president of MCA, will also assume the duties of National Show Coordinator. In the future, all show applications should be addressed to Watson and groups with questions concerning MCA shows should contact him at MCA.

The MCA Board of Directors is expected to review applications for the 1993 Grand National at its March meeting and consider applications for national shows at its April meeting.

All requests for National and Grand National shows must be filed on forms provided by MCA. Those forms can be obtained by contacting Watson at National Headquarters, P.O. Box 447, Lithonia, GA 30058.



Restoring Mustangs Since 1965. Bring us your MUSTANG or SHELBY ... We will custom build it exactly to your specifications. Our labor rate is \$8.00 per hour. Visit our museum with over 25 models of Convertibles, Fastbacks, GTs, Bosses, Cobras and every year Shelby on display. Personal tours with appointment. Send No. 10 SASE and \$2.00 for brochure and color picture.

TELSTAR MOTORS • 1300-1400 S. Kimball St. • Mitchell, SD 57301 • PHONE (605) 996-6550

COMPARE **QUALITY** • COMPARE **PRICE** • COMPARE **SERVICE!**

MUSTANG PARTS

money back guarantee!

BEFORE YOU BUY...
COMPARE paddock parts
 THERE IS A DIFFERENCE!

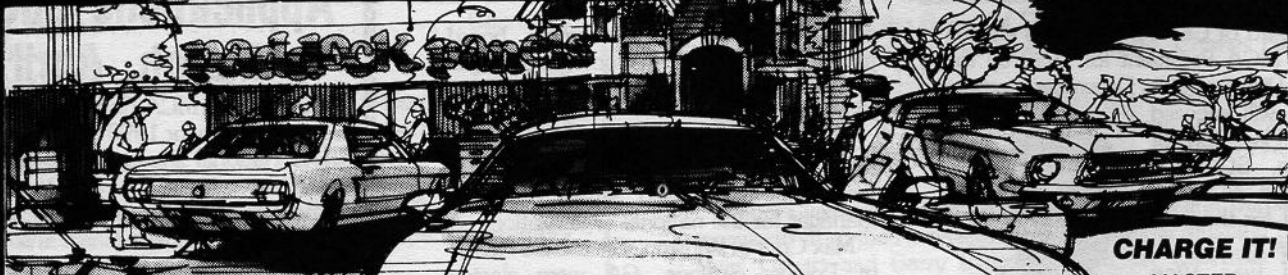

the world's largest supplier of mustang parts

STEERING

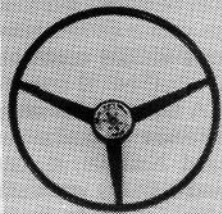

Repro colored steering wheels.

- 65 C5ZZ 3600RR Red
- 65 C5ZZ 3600BR Blue
- 65-66 C5ZZ 3600WR White
- 66 C6ZZ 3600BR Blue
- 66 C6ZZ 3600RR Red

ANY COLOR **\$149.95** ea.

BUMPERS

Highest quality reproduction bumpers available.

- 65-70 Front or rear .. from 79.95
- 65-68 Bolt kit 11.95

FRONT FENDER



- 64-'66 repro front fender.
- 64-66 Frt Fender ea 129.95
- 64-66 Frt Fender pr 259.90

REAR FULL FRAME EXTENSION

One piece unit that fits coupe & fastback. Can be trimmed to fit convertibles.

- 64-69 MM102-A-103LH
- 64-69 MM102-A-103RH

\$195.00 ea.

STEREOS



New factory made to fit AM/FM cassette stereos, 14 watts loaded with features. Fits into the dash without modifications. Many more models to choose from.

- 65-66 MSUSA2 149.00
- 67-73 LMUSA2 149.00

GOLF SHIRTS

NEW PADDOCK LOGO SHIRTS!
 Logo embroidered over left breast pocket. S, M, L, XL & XXL.

- 1120DG Dark green
- 1120MA Maroon
- 1120NV Navy
- 1120RD Red
- 1120WH White

\$24.95 ea.

GAS CAPS

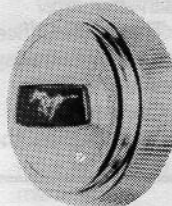

REPRO LOCKING GAS CAP!

Running horse is centered inside black latch. Two keys are included. Won't fit GT, Mach I or Shelby.

- 65-70 MLC1 ea. 59.95

CHARGE IT!

- MASTER CARD
- VISA
- AMERICAN EXPRESS
- DISCOVER CARD

STORE HOURS:
 Mon.-Fri. 8 to 5
 Saturday 9 to 3

YOUR "ONE SOURCE" FOR MUSTANG PARTS!

MOLDED CARPET

The very best molded carpet. Correct blend of material 80/20 for 65-68, 100% nylon for 69-73. Full cut 30 ounce 1/2" underlay pad bonded to the carpet.

- 65-73 All body styles 99.00
- 70-73 Mach 1 w/insert ... 144.95
- 65-73 Carpet underlay ... 34.95



NEW 1992 CATALOG

GET ON OUR MAILING LIST!

NAME _____
 ADDRESS _____
 CITY _____
 STATE _____ ZIP _____

For just **\$4.00** we'll send your MUSTANG catalog to you by mail along with placing your name on our mailing list. Simply pick up your phone and call either The Paddock **1-800-428-4319** or Paddock West **1-800-854-8532** and we'll place your order on your Visa, MasterCard, American Express or Discover Card. **ACT NOW!**

the paddock inc.

221 W. Main, Box 30, Dept. MT, Knightstown, IN 46148

paddock west

1663 Plum Lane, Box 8547, Dept. MT, Redlands, CA 92375

TOLL FREE ORDER LINE ONLY

IND. WAREHOUSE
800-428-4319
 Info Line: 317-345-2131

CAL. WAREHOUSE
800-854-8532
 Info Line: 714-335-3137

DEALER INQUIRIES WELCOMED-please inquire on your letterhead • Prices are subject to change without notice • Parts too big to ship UPS will be shipped via Truck Freight



Jack Yeager
MCA No. 411

Jack Yeager of Decatur, GA has been a member of the Mustang Club of America since its formation in 1976 and has served on the Board of Directors since 1978.

A member of the Georgia Regional Mustang Club, Jack was re-elected Publisher of *The Mustang Times* in December. He has held that position since 1989. Jack has also served as MCA vice president and sergeant-at-arms and was the group's first National Head Judge.

He writes a monthly column for *The Mustang Times*.

The owner of B&J Communications, Jack and his wife, Betty, have two children, Ken (a former MCA board member) and Judy. Betty is also a former MCA board member and produced the name "Thoroughbred" for that elite MCA show class.

Jack and Betty are the owners of several Mustangs, including a 1965, a 1971, a 1966 convertible, and 1968 Shelby GT 350.



Lena Johnson
MCA No. 7547

Lena Johnson of Chattanooga, TN has been a member of the Mustang Club of America for the past eight years.

An active member of the Scenic City Mustang Club, she has served as secretary and treasurer of that MCA Regional Group.

Lena and her husband, James G. Johnson, are owners of J.J.'s Mustang Parts in Chattanooga. J.J. is also a member of the MCA Board of Directors.

Long-time members of MCA, the Johnsons are frequently seen with their parts trailer at Mustang shows throughout the southeast.

The Johnsons have two children and five grandchildren.

The couple owns a 1965 Mustang GT convertible, a 1965 GT fastback, a 1966 GT convertible, a 1968 California Special, a 1968 Shelby convertible and a 1990 LX convertible.



Ricky Simmons
MCA No. 17874

Ricky Simmons of Demorest, GA joined the Board of Directors of the Mustang Club of America in 1989. He has been an MCA member since 1986.

A member of the North Georgia Mustang Club and Georgia Regional Mustang Club, Ricky served as MCA Assistant National Head Judge in 1991 and has been named National Head Judge for 1992.

He is the owner of Simmons Grassing Company, Inc., which specializes in grassing highway rights-of-way.

Ricky and his wife, Carolyn, have two children, Ginny and Bill.

During the 1991 show season, Ricky served as acting head judge at several MCA National Mustang shows. Along with 1991 MCA President Charles Hampton, he presided over the 1991 National Judges Rules Meeting held in Atlanta last September.

BLACK • RED • BLUE • YELLOW • TAN • WHITE • GREEN • ORANGE • CREAM • CAMOFLAGE

SHOW SEATS

- Black Powder Painted Frame
- 350-pound Capacity
- Water Repellent
- Mildew Resistant
- Color Fast
- Folds To 30" X 6" DIA
- One-Year Warranty

\$44.95 EACH

**Free Shipping
Free Storage Bag**

Visa • MC • Discover

MUSTANG FARM

3853 Moon Station Road
Kennesaw, GA 30144

(404) 427-0382

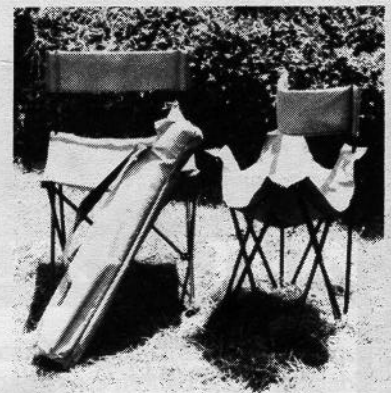

"Parts Isn't Parts..."

Ever been shopping for classic '65-'73 Mustang parts and come across what appears to be a great deal, but then you begin to have doubts that maybe it's not such a good thing? That maybe this certain part isn't top quality, or doesn't have any kind of guarantee.

Probably so. And what did you do about your doubts? Go ahead with the order and take the consequences?

Obviously there are other options available. At Larry's Thunderbird & Mustang Parts we understand your parts buying concerns and are here to help remove the guesswork and doubts associated with the restoration process.

Concours-Quality Parts & Service

Over the 20 years that Larry's has been in business we've gained a reputation among enthusiasts for having the most complete and comprehensive '64 1/2-'73 Mustang parts selection in the industry. Our goal is concours-winning quality. And we have achieved that. But

we can't rest on our laurels. Having a huge selection of award-winning parts doesn't mean much unless we make sure you get what you need for your vehicle. Our parts specialists have the experience necessary to make sure you get the right parts for your particular application.

Lowest Prices In The Industry

Of course we continue to have the most competitive pricing around. Compare our prices with the competition and we'll

beat them - always. This converts to great savings on your parts with money left over to finish your restoration project. We continue to prove that year after year.

Ordering Parts Is An Easy Process

Larry's offers our latest edition of '64 1/2-'73 Mustang Parts Catalog for only \$2.00. To get your hands on this book full of illustrations, photos, and part listings, call, write or FAX us your request. We'll send your copy out right away.

Comprehensive Parts Catalog

At Larry's we make ordering parts convenient. Use our Toll-Free numbers and charge to your credit card (VISA®, MasterCard®) or have it sent COD. Orders also accepted by FAX. So if you have doubts about your parts purchase, give us a call. You can bet on Larry's to give you the parts and service you need.



'91 Catalog

We've Got The Parts For Your '64 1/2-'73 Mustang

- Upholstery
- Interior Trim Items
- Engine Components
- Clutch
- Brakes
- Electrical
- Weatherstripping
- Exterior Trim
- Body Panels/Sheetmetal
- Window Glass
- Audio Components
- Suspension Components
- Bumpers
- Decals
- Literature/Manuals

Catalog Requests Call 714.871.6432

Parts Orders Call: 800.854.0393
 (In CA) 800.698.2473 or 714.871.6432
FAX Orders or Requests: 714.871.1883
Hours: Mon.-Fri. 8:30AM to 6:30 PM
Sat. 9:00 AM to 1:00 PM



511 S. Raymond Ave. Fullerton CA 92631

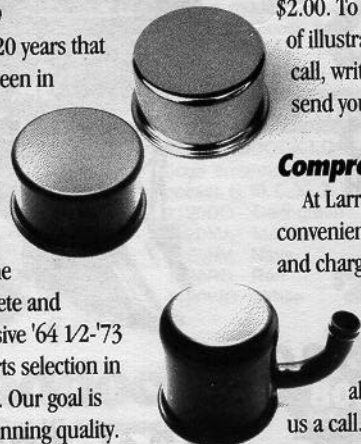

Larry's Keeps Your Classic Mustang Looking Good!

MCA's 16 Year History Is Interesting Reading

The publication of the lengthy rules corrections and clarifications approved at last September's MCA Judges' Meeting forced us to delay the introduction of a new feature, "MCA Notebook," last month.

But we're back on track now and you'll find this two-page article in your February *Mustang Times*.

It's an interesting summary of the 16 year history of MCA, compiled by *Mustang Times* staffers Steve McMullan and Kitty Wilmot.

I know many of our newer members will find this interesting reading, and I think some of our long-time members will as well.

We plan to use "MCA Notebook" to inform our readers about a number of topics related to the national organization — articles from how to become a Certified or Gold Card judge to how a regional group can plan, apply for and stage a National or Grand National show.

By Jack Yeager

I hope you'll take time to read MCA Notebook this month.

MT□MT□MT

And speaking of history, we're also planning to take you back a few years with a feature on the early issues of *The Mustang Times*.

Some of our new members might not know it, but *The Times* has been published by MCA since the club's second year of existence. My son, Ken, has the only complete collection of *Mustang Times* issues that I know of, and we're going to reproduce some excerpts from these early issues to give you an idea of where we started — and how far we've come.

I hope you'll be watching for this interesting feature this coming spring.

If you enjoy reading *Mustang Times*, you might even enjoy it more if you saw your own Mustang featured!

We welcome contributions from our readers. If you have a clear snapshot of your favorite Pony, send it in — along with an owner's information sheet (published quarterly) — and we'll be glad to consider it for our monthly "Horse Show" page.

If there's an interesting story behind your car, we invite you to sit down and write it out in your own words and mail it in, along with three to six photos. If the story is interesting and unusual enough, it could very well be selected as one of our monthly "Feature Cars."

While the weather's still too cold to go out for a spin with the top down you might spend a few minutes writing us and providing some details about your own Mustang.

We look forward to hearing from you!

TRAINOR
STUDIOS
AUTOMOTIVE ILLUSTRATION



ORIGINAL AUTOMOTIVE ILLUSTRATION

One of a kind, hand drawn, true-to-life color illustrations of your prized collector car! Each illustration is a unique creation of incredible detail, drawn directly from your photograph. Each Trainor original comes matted and is available with or without frame and mounting hardware. Black and white pen and ink illustrations are also a specialty. Call us for any type of automotive illustration. Please allow 3 weeks for delivery.

The Perfect Idea for That Once-In-A-Lifetime Gift, Fund Raisers, Club Prizes, Raffles, Etc.

939 Dallas Way • Lawrenceville, GA. 30245 • (404) 963-7840

Nebraska Tax Proposal Concerns This Mustanger

Editor:

A few months ago I alerted you and the members of MCA to a bill introduced in Congress by Sen. Roth of Delaware that sought to remove all pre-1980 cars from circulation for environmental reasons.

At that time, I expressed my concern not that his ill-conceived bill would pass, but that it might inspire other, more effective, efforts to legislate older vehicles — and along with them our hobby — out of existence.

I foresaw, for example, states enacting punitive taxation to make owning an old car prohibitive.

Now, as if to confirm my worst fears, I find this story from a Nebraska Mustang club:

"At our August meeting, D.J. Hogan informed us of a plan under consideration by the Nebraska Energy Policy Council concerning property taxes on older cars. The plan states:

"Remove older, fuel-inefficient vehicles from service to increase average miles per gallon and reduce exhaust emissions....As part of the overhaul of Nebraska's property tax system, the state should be encouraged to tax cars and light duty trucks based on fuel utilization standards and to assess the feasibility of a pollution tax or an environmental surcharge on motor vehicles at the same time of annual registration. This tax should be a significant encouragement to abandon the use of older vehicles."

"The tax would be assessed at the time of annual registration. It is unclear at this time how, for example, a mid-60s car would be rated — whether by age or fuel consumption — or if the rating would take into account any consumption variations, daily driving, etc., or what determinates would be used concerning age limits or consumption rating. If you are interested in making any comments, or would like to see a copy of the plan, please write to Nebraska Energy Policy Council, P.O. Box 95085, Lincoln, NE 68509, Attn.: Allison Meyer."

You don't have to be a resident of Nebraska to be alarmed at these proposals. Similar measures are being considered, or have already been enacted, by other states and it's a safe bet that Kansas and Missouri — and other parts of the nation — are not far behind.

As to the Roth bill, it now appears to have died a quiet death in Congress — but not before the Senator was forced to add staff to his office to handle the flood of mail and phone calls from outraged auto hobbyists.

Vintage Mustang Club member Pat Sterbenz tells us, however, that CTCI, the na-

tional Thunderbird Club, has learned of a similar measure that will soon be introduced, probably as an amendment to another, unrelated bill.

I'll try to keep you informed periodically of further developments on this issue. MCA members can help by keeping their ears to the ground and letting *The Mustang Times* and their fellow Mustang hobbyists know if they come across any news on the subject.

Jack Sell
Vintage Mustang Club
of Kansas-City

Rotary Board Praises Rochester Club For Help

Editor:

On behalf of the Board of Directors of the Rochester Rotary Service Foundation, I would like to thank Mr. John Foss and the Shelby Mustang Club of Rochester for raising \$1,611.65 for the Rotary Sunshine Camp.

We are deeply grateful for the hard work this group did in staging the 15th Anniversary All-Makes Car Show.

Each summer more than 350 physically disabled young people experience the joy of camping, and receive specialized training to improve their quality of life in an environment full of love and encouragement at Sunshine Camp.

Many of these young people are also from disadvantaged homes. The time spent at camp is free of charge for most of the campers.

The importance of camp to the youth who attended is hard for us to comprehend, and I can't begin to communicate what camp means to each one of these young persons. However, we do get a glimpse of the meaning of camp from Chris: "I like camp because I get tired of hospitals, and I get to do things I otherwise would not be able to do. Sometimes it's fun just being a kid."

Again, our sincere appreciation to the Shelby Mustang Club of Rochester.

Norman A. Carlson
Development Director
Rochester Rotary Service Foundation

New Member Requests Correction Of Listing

Editor:

I joined the Mustang Club of America in October. My membership number is 25204.

In listing new members in your magazine, the *Mustang Times*, Vol. 15, No. 11, on

Page 39, I am listed as Joe Maroccia of Peekskill, NY.

The spelling is wrong. I am a female and I spell my name Jo.

I would appreciate you making a correction of this error.

Thank you for your prompt attention to this matter.

Jo Maroccia
Peekskill, NY

(Editor's Note: Our apologies, Jo, for our mistake in listing you in our New Members section. We would like to welcome you to MCA and thank you for bringing this error to our attention and giving us an opportunity to set the record straight.)

Club Member Thanks Randy Church For Help

Editor:

Not too long ago, I was having a great deal of difficulty trying to remove the radio from my 1985 Mustang SVO.

After a few hours of frustration, I decided to call Randy Church, late model MCA Gold Card Judge, and ask him for some advice.

He was extremely polite and seemed to empathize with my situation. He said he would look up some information in his books and call me back.

In about a half-an-hour, he returned my call (long distance) and was able to give me the information I needed.

It is people like Mr. Church who give the Mustang hobby such a good name, and I would like to thank him for it.

Robert Anzalone
MCA Member #23166

Your Letters Are Welcomed!

Comments from members of the Mustang Club of America are welcomed by *The Mustang Times*.

To have your opinions included in the monthly "Readers' Forum" section of your club magazine, address your letter to: Readers' Forum, *The Mustang Times*, P.O. Box 447, Lithonia, GA 30058.

Please include your membership number and city and state of residence on your correspondence.

All letters are subject to standard editing, but every effort will be made to include as many comments as possible in this column each month.

We'd like to hear from you today!

J.C. Taylor Antique Auto Insurance Information Sheet

Underwritten by Zurich Insurance Co., with offices and claim facilities in principal U.S. cities

1 (800) 345-8290 • (215) 748-0567 • (215) 853-1300

Applicant _____ Date of Birth _____ Occupation _____
 Address _____ Zip _____

1. List all losses in past three years and moving violations—antique and modern cars. (Date-Cause-Payment. Include drivers under 25 years of age.) _____

Number of Antique Autos owned _____ Operator License Number _____

2. Total Annual Mileage: Club Functions _____ Other Purposes _____

3. Name of antique or car club to which you belong _____

4. List modern cars used for daily transportation (owned _____ or company cars _____ ?) _____

5. Where are cars garaged? Under one roof? Construction of garage—brick-frame-fire resistive _____

6. Has rated horsepower or other specifications been changed? Yes _____ No _____ If yes, explain: _____

7. The following coverages are available. Indicate those desired by placing "X" in proper boxes.

- Liability (\$100,000 single limit) Bodily Injury and Property Damage. Annual Rates: 1st car \$15.00, 2nd \$10.00, 3rd \$5.00
- Uninsured/Underinsured Motorist—Rates as required by your State. \$ _____ Car 1 \$ _____ Car 2 \$ _____ Car 3
- Liability (\$300,000 single limit) Bodily Injury and Property Damage. Annual Rates: 1st car \$20.00, 2nd \$14.00, 3rd \$8.00
- Medical Payments of \$1,000.: 1st car \$4.00, 2nd car \$3.00, 3rd car \$2.00. Units in excess of 3, NO CHARGE.

Physical Damage

- Physical Damage (Comprehensive Includes Fire and Theft)—Annual Rate \$0.35 per \$100 of insurance for each vehicle. NO DEDUCTIBLE. 25 yrs. or older
 - Physical Damage (Collision)—Annual Rate—\$0.35 per \$100 of insurance for each vehicle. NO DEDUCTIBLE. 25 yrs. or older
- (Note—Collision is not written as a singular coverage but is available with Comprehensive.)**
- Physical Damage (Comprehensive Includes Fire and Theft)—\$0.70 per \$100 of insurance for each vehicle. Less than 25 yrs.
 - Physical Damage (Collision) \$0.70 per \$100 of amount of insurance for each vehicle. Less than 25 yrs.

8. Date this coverage is to be effective _____ Policy Minimum Premium \$50.00

ANTIQUE AUTOS TO BE INSURED

(Include picture of car if possible.)

Year	Make	Body Type Series or Model	Series or Motor Number	Present Valuation (Amount of Insurance)
1. _____	_____	_____	_____	_____
2. _____	_____	_____	_____	_____
3. _____	_____	_____	_____	_____
4. _____	_____	_____	_____	_____

Use separate sheet for additional cars to be insured.

An application may be forwarded to you for additional information.

My vehicle(s) will be used mainly in exhibitions, club activities, parades and other functions of public interest and will not be used primarily for the transportation of passengers or goods. If you are a resident of CT, FL, PA, or N.J., send copy of regular car policy.

Signature: _____ Date: _____

Note: Your insurance becomes effective upon payment of the premium and acceptance of the risk. Please sign and forward with your remittance, payable to:

J.C. TAYLOR ANTIQUE AUTO INSURANCE AGENCY, INC.

320 South 69th Street
 Upper Darby, Pennsylvania 19082

1 (800) 345-8290 • (215) 748-0567 • (215) 853-1300



**OFFICIAL
MCA**



**1964 1/2-73
MUSTANG
IDENTIFICATION PLATE
DECODER**

MCA Now Offering Mustang ID Decoder

The Mustang Club of America is now offering a pocket-sized, official Identification Plate Decoder — the same information manual used by certified judges at national shows to verify ID plate information on competing cars.

The manual, which covers 1964½-73 models, is a convenient 3½-by-6-inches — small enough to fit into your pocket for those hunting trips through the junk yards.

The decoder is available for \$5.00, plus \$1.00 shipping and handling.

The manual breaks down information contained on your vehicle's ID plate — enabling you to decode color, engine, transmission, rear axle ratio and other data.

The book also contains complete production figures for Mustangs and Shelbys.

The handy, easy-to-understand booklet provides all the information you will need to completely interpret all the information con-

tained on your identification plate.

MCA will also be offering an Official 1974-1991 Mustang Identification Plate Decoder Manual later this year. This booklet will contain the same ID plate information for later models.

To order your 1964½-73 Identification Plate Decoder, send check or money order — payable to the Mustang Club of America — for \$5.00 plus \$1.00 for shipping via first class mail to: Decoder, Mustang Club of America, P.O. Box 44, Lithonia, GA 30058.

Order yours today in time for the upcoming 1992 Mustang show season.

Use Mustang Times Classified Ads!



Decide and Drive. Alamo gives you two ways to save.

Choose a free upgrade or \$15.00 OFF your association's weekly rate in both the U.S. and U.K. As a member, you save either way. See certificate for terms and conditions. Alamo features a fine fleet of General Motors cars, all with *unlimited free mileage* nationwide. Special weekend rates are available by requesting Rate Code A1.

For reservations, call your Professional Travel Agent or call Alamo at 1-800-327-9633. Be sure to request Rate Code BY and use your membership ID number _____.



Where all the miles
are free™



Alamo features fine General Motors cars like this Cadillac Sedan De Ville.

FREE UPGRADE NATIONWIDE

1. Certificate good for ONE FREE UPGRADE to next car category; luxury and specialty cars excluded in the U.S. UPGRADE valid up to an E car category in the U.K. subject to availability at time of rental.
2. This certificate is redeemable at all Alamo locations in the U.S.A. and United Kingdom. Value of certificate will be at current exchange rates where applicable. Once redeemed, this certificate is void.
3. One certificate per rental, not to be used in conjunction with any other certificates, offers.
4. This certificate and the car rental pursuant to it are subject to Alamo's conditions at the time of rental. Minimum age for rental is 21 (18 years of age in New York state). All renters must have a valid driver's license.
5. Certificate may be redeemed only for the "basic rate" of the Alamo car rental, which does not include Rental Deposit (\$200/week or \$50/day in the U.S.A.; £900 per day or less in the U.K.), fuel, tax, airport-imposed taxes, fees, additional upgrades or applicable drop charges. Optional CDW (\$800 per day or less in U.S.A.; £900 per day in the U.K.), Personal Accident and Effects Coverage, Extended Protection and other optional items are extra and are not included in the basic rate.
6. This certificate is null and void if altered, revised or duplicated in any way. In the event of loss, certificate will not be replaced.
7. Offer valid through 6/30/92.
8. A 24-hour advance reservation is required. Upgrade is subject to availability at time of rental.
9. Offer not valid 12/19/91-12/28/91, 2/13/92-2/15/92, and 4/16/92-4/18/92.
10. Certificate must be presented at the Alamo counter on arrival.
11. For reservations call your Professional Travel Agent or call Alamo at 1-800-327-9633.

Alamo features fine General Motors cars like this Buick Regal.

U66B I.D. # _____



Where all the miles
are free™

\$15 OFF ANY ASSOCIATION WEEKLY RENTAL

1. Offer valid on any 5 day or longer rental.
2. One certificate per rental, not to be used in conjunction with any other certificates, offers.
3. Certificate must be presented at the Alamo counter on arrival.
4. This certificate is redeemable at all Alamo locations in the U.S.A. and United Kingdom. Value of certificate will be at current exchange rates where applicable. Once redeemed, this certificate is void.
5. The maximum value of this certificate which may be applied toward the base rate of one rental is \$10.00 OFF on any Economy through Luxury car category. Certificate must be presented at the time of rental.
6. No refund on unused portion of certificate.
7. This certificate and the car rental pursuant to it are subject to Alamo's conditions at the time of rental. Minimum age for rental is 21 (18 years of age in New York state). All renters must have a valid driver's license.
8. Certificate may be redeemed only for the "basic rate" of the Alamo car rental, which does not include Rental Deposit (\$200/week or \$50/day in the U.S.A.; rental charges plus £100 in the U.K.), fuel, tax, airport-imposed taxes, fees, additional upgrades or applicable drop charges. Optional CDW (\$900 per day or less in U.S.A.; £900 per day or less in the U.K.), Personal Accident and Effects Coverage, Extended Protection and other optional items are extra and are not included in the basic rate.
9. This certificate is null and void if altered, revised or duplicated in any way. In the event of loss, certificate will not be replaced.
10. Certificate cannot be used in conjunction with any other Alamo's special offers. This certificate is not redeemable for cash.
11. Offer valid through 6/30/92.
12. A 24-hour advance reservation is required. Reservations are subject to availability at time of booking.
13. Offer not valid 12/19/91-12/28/91, 2/13/92-2/15/92, and 4/16/92-4/18/92.
14. For reservations call your Professional Travel Agent or call Alamo at 1-800-327-9633.

Alamo features fine General Motors cars like this Cadillac Sedan De Ville.

D09B I.D. # _____



Where all the miles
are free™

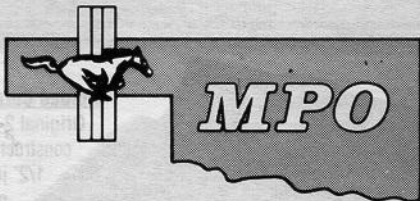

MUSTANG PARTS

**IF IT'S AVAILABLE FOR YOUR
1964-73 CLASSIC MUSTANG
WE'RE STOCKING IT!**

Wheels	Bumpers	Weather Stripping
Brakes	Air Conditioners	Rubber Parts
Steering	Heater Parts	Carpeting-Molded
U-Joints	Stripe Kits	Floor Pans
Radiators	Wiring	Patch Panels
Water Pumps	Lights	Upholstery - Including
Grilles	Fenders	"Pony" and "Mach I"
Fuel Lines	Hoods	Decals
Carburetor Kits	Speedometer Cables	Misc. Hardware Kits
Alternators		



**378 pages
over
7,000 items**

*Send \$5.00 for your catalog. Plus \$3.00 postage and handling.
Outside continental United States add \$15.00.*



MUSTANG PARTS OF OKLAHOMA

6505 S. Shields • Oklahoma City, OK 73149-1311
Phone: (405) 631-1400 FAX (405)631-1401
Store Hours: Mon. - Fri. 9-7; Sat. 9-3

With 3 shipping depots we deliver FAST!



Ready-to-install
**AM/FM Cassette
Decks** start at
\$144.95. Pioneer
& Kenwood units
are also in stock.

Our catalog
features 3
pages of parts
for **AC Systems**.



Correct configuration
KYB Gas-A-Just shocks
only **\$99.00**/set of 4.
Huge stock!

Heavy-Duty Coils- coated
with blue PVC! **\$74.95/pr.**
High rate, won't corrode!



Save!!

NPD has the Nations **LARGEST STOCK** of reproduc-
tion sheet metal! •• **Trunk Lid**- '65-66 **\$149.95**;
•• **Fender**- '65-66 **\$119.95**; '67-68 **\$129.95**;
'69-70 **\$139.95** •• **Hood**- '65-66 **\$149.95**; '67-68 w/o
ind **\$159.95** •• **Quarter Panel**- '65-66 Coupe/Conv
\$129.95 •• **Full Quarter Repair Panel**- '65-68 **\$79.95**;
'69-70 Cpe/Conv **\$129.95**, FB **\$99.95**; '71-73 **\$99.95**
•• **Front Valance**- '65-68 **\$39.95**; '69-70 **\$69.95**;
•• **Rear Valance**- '65-68 **\$39.95**; '69-70 **\$44.95**
'71-73 **\$54.95** •• **Tail Light Panel**- '65-68 **\$49.95**; '69
\$94.50; '70 **\$79.95**; '71-73 **\$99.95**

**OEM Quality
Dash Pads**
only **\$149.95**



Color selection:
'65 Black, Blue, Red
'66 Black, Blue, Burgundy

**FREE SHIPPING
on UPS orders over \$200**

Copyright © 1991 by **NATIONAL PARTS DEPOT**

Rocker Molding Set w/clips: '65-66 **\$89.95**; '67-68 **\$59.95**

**Molded Rubber
Trunk Mats**
only **\$39.95**

Fits all
bodies
- from
'65-70!

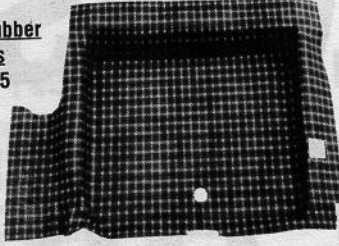

Cowl Cover-Improved design w/solid 1-piece knurled
aluminum knobs. '65-66 **\$29.95**; '67-68 **\$31.95**



Fuel Tanks '65-68
16 gal w/o drain
\$99.95;
w/drain
\$124.95

**NPD IS REPAIR
PANEL CENTRAL!**

**Lowest overall pricing!
Largest inventory!**



Our Catalog

Correct '65-73 Mustang parts



Lock & Key Sets-
Complete selection of coded
kits. Shown here '65-66
deluxe door & ign.
\$39.95

**World's Best
Reproduction Bumpers**
'65-68 FT or RR only **\$77.95**
'69-70 FT or RR only **\$84.95**

Front Airfoil only **\$59.50** for '69-73. Incl hardware
Rear Deck Wings for '69-73 only **\$169.00**



See catalog for complete
listing. All prices pair.

Concours Weatherstripping
Door- '65-66 **\$24.50**; '67-68
\$29.95; '69-70 **\$49.50**
Siderail- '65-66 FB **\$54.95**;
Cpe **\$29.95**; '67-68 FB **\$59.95**;
Cpe **\$29.95**; '69-70 Cpe **\$59.95**;
'69-70 FB **\$109.50**

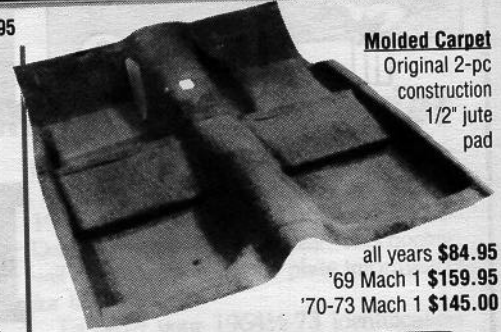

Molded Carpet
Original 2-pc
construction
1/2" jute
pad

all years **\$84.95**
'69 Mach 1 **\$159.95**
'70-73 Mach 1 **\$145.00**



Concours interiors:	Set Pair/Door		Set Pair/Door	
	Uph	Panels	Uph	Panels
'65-68 std	\$159.95	\$66.95	'71-73 std	\$194.50 \$89.00
'67 del	\$159.95	\$159.00	'69 Mach 1	\$279.00 \$369.00
'68 del	\$159.95	\$149.95	'70 Mach 1	\$279.00 \$369.00
'65-66 del	\$214.95	\$129.95	'70-73 del	\$279.00 \$369.00
'69 std	\$184.50	\$69.00	'71-3 Mach	\$345.00 \$369.00
'70 std	\$194.50	\$99.00		



Free Catalog!



Call **904-378-9000**
hotline open 24 hrs
or write: NPD Mustang Catalog
DEPT [MCAMT]
3101 SW 40th Blvd
Gainesville, Florida 32608



ORDER TOLL FREE

Florida

local 904-378-2473
toll free all states
800-874-7595

California....

local 805-654-0468
toll free all states
800-235-3445

Michigan....

local 313-591-1956
toll free out of state
800-521-6104

HOURS
M-F 8am-7pm;
Sat 9am-5pm;
Sun 11am-5pm



Open 7 days

**National
Parts Depot**

World's Largest Supplier

Club Has Rich History

March Marks MCA's 16th Anniversary

March 9, 1992 will mark the 16th anniversary of the Mustang Club of America, the world's largest organization devoted to the preservation and appreciation of the automobile industry's first "Pony Car."

The concept of a national club for Mustang owners was first discussed on that day in 1976 when a group of 14 individuals met in Lithonia, GA to exchange ideas about the restoration and preservation of their own Pony cars, which had first made their appearance on the market on April 17, 1964.



**Founded
1976**

Members of the group decided to place a classified advertisement in the *Atlanta Journal-Constitution* to invite other Georgia Mustang enthusiasts to a meeting at Stone Mountain Park in Atlanta. That meeting was held Sunday, April 11, 1976 with 30 people attending. Those 30 Mustangers officially formed the Mustang Club of America on that day.

Stan Jones was elected the first president of MCA and by the time the fledgling group held its second public meeting on May 2, 1976, club membership had already exceeded 100.

Bill Dillard, newly-elected MCA National President, was among that group of 14 original founders of the national organization. Dillard, who has been a member of MCA's Board of Directors since 1978, has a membership number of seven.

MCA'S FIRST GRAND NATIONAL

Elated by the favorable reception the organization received in its infancy, MCA began planning for its first Grand National Mustang Show. When that event was held in Atlanta in August, 1976, membership had topped 250. Even more startling to its founders, more than 1,200 people attended the first Grand National (some from as far away as Canada) and a large field of 100 cars entered the popular-vote car show.

With membership continuing to grow throughout 1976, the organization's leaders voted to cut off "charter memberships" in MCA at 350. Today, approximately three dozen of those charter members are still active in the organization, 16 years after its inception.

In May of 1977, just three months before MCA's second Grand National, the organization began publication of *The Mustang Times*, which debuted as a 6-by-9-inch newsletter designed to provide a channel of communication between the organization and its growing membership.

In August of that year, Atlanta played host to the second MCA Grand National, which attracted more than 200 entries from 20 states. By then club membership had grown to more than 600, including Mustangers from several foreign countries and numerous states.

The first MCA-sanctioned show held outside of Atlanta was the 1978 Eastern National, held in Kingsport, TN in May. When the organization held its third Grand National in Atlanta that August, more than 5,000 attended, attesting to the fact that the Ford Mustang had already become an automotive classic.

MCA: THE WORLD'S LARGEST

MCA had grown to the largest Mustang Club in the world by August, 1979, when the fourth Grand National was held in Atlanta. Membership exceeded 3,400 and the club had chartered 27 affiliated regional groups.

Eastern National Mustang Shows were held in Chattanooga, TN in May, 1979 and Knoxville, TN in May, 1980. Also that year, *The Mustang Times* was converted to a full-sized magazine and continued to be the primary means of communication between the national group and its growing worldwide membership.

The first MCA sponsored Mustang show held outside the southeast was the first Mid-Central National, held at the Indianapolis Motor Speedway in June, 1980. The Mustang Club of Indianapolis continues to hold a regional MCA show at the Speedway each year and in 1991 attracted more than 310 cars.

A two-lap spin around the world-famous "Brickyard" — which was a feature of the first Mid-Central National in 1980 — is still one of the most popular activities at the Indianapolis show. The Mustang Club of Indianapolis will host the first MCA National of 1992 at the speedway in June.

In mid-1981, MCA established its first National Headquarters office in Lithonia, GA to serve a roster which by then had grown to more than 4,200 members.

The fourth Eastern National, hosted by the Central South Carolina Regional Group, was held in Col-

umbata, SC and the first Dixie National MCA Show, sponsored by the Birmingham Regional Group, were both held in 1981.

Kingsport, TN was the site of the first MCA Grand National to be held outside of Atlanta. That event, sponsored by the First Tennessee Regional Group, was held in August, 1981, and drew a field of 226 Mustangs and more than 500 people attended the awards banquet which followed the show. The First Tennessee Regional Group also hosted the 1991 MCA Grand National held this past August in Kingsport.

ANNIVERSARY SPURS MEMBERSHIP

Publicity surrounding the celebration of the 20th anniversary of the Ford Mustang in 1984 spurred renewed interest in MCA as membership climbed to more than 5,000. In addition to individual members, the group continued to add to its growing list of affiliated regional groups, and many of those sponsored special anniversary activities during that commemorative year.

Membership in MCA, which had been limited to 1964½-73 models, was expanded to include all Mustangs in 1986. Though that decision was not universally popular among all members, it proved to be a crucial factor in the continued growth of the organization.

While many members of the maturing "baby-boom" generation continued to insist that the "original" Mustang had disappeared with the introduction of the Mustang II in 1974, the escalating cost of purchasing and restoring the earlier "classic" models was beginning to become prohibitive to younger auto enthusiasts. MCA's decision to expand membership to include all Mustangs broadened the club's appeal to a new generation of Pony car lovers. Today, in fact, more than a third of the Mustangs entered in many MCA National and Grand National Shows are late models.

During the late 1980s and the first year of the 1990s, a significant portion of the club's growth has been among owners of later model Mustangs.

30TH ANNIVERSARY ON HORIZON

Another burst of renewed interest in Lee Iacocca's "working man's sports car" came in 1989, when the 25th anniversary of the Mustang's introduction was celebrated. Numerous events, including a coast-to-coast "American Pony Drive" attended by a group of European Mustang owners, resulted in national publicity for both the Ford product and the Mustang Club of America.

Club officials anticipate that the upcoming 30th anniversary celebration in 1994 — and the expected introduction of the "third generation" Mustang in 1994 or 1995, will again spark interest in MCA.

Today MCA's membership continues to approach the 6,000 mark and nearly 100 affiliated MCA Regional Groups are spread across most of the 50 states and in portions of Canada.

The MCA's Board of Directors meets monthly in Atlanta, GA to oversee the national organizations administration, finances and activities.

Regional groups seeking to sponsor MCA-sanctioned National and Grand National shows each year submit detailed applications which are reviewed and acted upon by the board. Some specific stipulations are imposed by MCA for National and Grand National Shows, but for the most part, Regional Groups have a great deal of latitude in organizing and staging these well-attended events.

All National and Grand National shows are promoted months in advance in *The Mustang Times* and the national organization pays transportation costs for the MCA President, the National Head Judge, and magazine staffers to attend these sanctioned events. In 1992, a record number of MCA-sanctioned shows were held in various parts of the country.

PROTECTING THE MUSTANG'S VALUE

MCA has also been credited with enhancing the appreciation of the Mustang as a collectible classic automobile by the drafting and refinement of its comprehensive Official Judging Rules.

These rules, which are in a constant state of revision and evolution, provide comprehensive documentation of the similarities and differences of the various Mustang models from the original 1964½ versions to current models.

The MCA rule book itself is a virtual mechanical history of the Ford Mustang and is the "bible" of authenticity for those evaluating these vehicles.

Show rules are made by the membership and all members who attend MCA's annual National Judges' Meetings are eligible to offer input and vote on the judging standards. Though the Judges' Meeting is held every year, rules changes are permitted only every other year. Revisions and clarifications of the club's rules are printed each January in *The Mustang Times* and are also published in booklet form for the convenience of members.

The MCA National President also appoints a National Head Judge who is responsible for attending and supervising judging at all sanctioned events and enforcing, explaining and interpreting the official requirements which serve as the mandatory judging standards at National and Grand National shows.

The national organization certifies show judges and offers a prestigious "Gold Card" to judges with exceptional experience and knowledge of the Mustang.

The MCA's affiliated Regional Groups are the backbone of the worldwide organization. These groups are granted charters by the national club and are guaranteed specific territory rights for their local organizations.

Most of these chartered local clubs hold annual Regional Mustang Shows, cooperate with other automobile clubs in joint activities, and sponsor a wide variety of activities, trips and outings for their member families, and share their experiences and knowledge relating to the restoration of their own classic Mustangs.

Many also are major contributors to charitable organizations in their communities and a surprisingly large number of Mustang clubs are deeply involved in fund raising projects that benefit needy children.

Each Regional Group elects a National Director, who is that club's liaison with the national organization.

During the past 16 years, MCA has grown from a collective idea in the minds of 14 Mustang enthusiasts to the world's largest organization of Pony car owners, but it has remained dedicated to the mission established by its founders: the preservation, restoration and enjoyment of the Ford Mustang.

(Editor's Note: Mustang Notebook is a new monthly feature of The Mustang Times. This summary of the history of the Mustang Club of America was compiled by Editor Steve McMullan and Assistant Editor Kitty Wilnot with assistance from Jim and Sue Osborn.)



13TH ANNUAL GULF COAST REGIONAL MUSTANG SHOW



MARCH 27-28, 1992 - PENSACOLA, FL

Show Headquarters: University Mall, Pensacola, Florida

March 27: 8 AM to 5 PM: Vendors set up. Tech Inspection available and encouraged.
6 PM to 11 PM: Hospitality Party. Fish Fry and entertainment, Hampton Inn.

March 28: 7 AM to 12 NOON: Tech Inspection and parking.
12 Noon to 5 PM: Judging.
7 PM: Awards Presentation

Show Site: Directly in front of University Mall. Exit from I-10 (Exit 5) and follow show signs.

Vendors: Please Pre-Register by March 15. Notification of space will be confirmed.

Raffle Car: 68 Mustang Convertible. To benefit Ronald McDonald House, Transportation Fund for the Shrine Hospital for Burned Children, and Sacred Heart Children's Hospital.

Parking & Security: Designated Mall parking space for trailers and motor homes (No Hook-ups). Look for signs. 24 hr. security during show dates.

On Site Motels: Mall Holiday Inn (on-site) \$53 (plus 9% tax) (904) 474-0100
Hampton Inn \$47 (plus 9% tax) (904) 477-3333
(Reservation Deadline March 10. Specify Mustang Show)

Special Interest: **Ford powered 1960-1973 cars only. No trucks.**
No umbrellas or aerosol cans on show grounds.

All Show Vehicles must remain in place until 5:00 PM March 28.

NOTE: Call Motels directly. Do Not call 800 Reservation Number.

—Paid Advertisement—

(PLEASE PRINT)

REGISTRATION

Name _____ MCA # _____ Exp. Date: _____

Address _____ City _____ State/Zip _____

Car #1: Year _____ Body Style _____ Serial # _____ Color _____

Car #2: Year _____ Body Style _____ Serial # _____ Color _____

Early Registration by March 15, 1992. Day of show add \$5.00 to all entries.

Car Registration	(\$15/each)	_____	Car Classes	Car #1	Car #2
Vendor Space (10' x 20')	(\$25/each)	_____	Concours (driven)	_____	_____
Pony Corral	(\$10/each)	_____	Concours (trailerd)	_____	_____
Raffle Tickets	(\$1/each)	_____	Street	_____	_____
	or 6/\$5.00	_____	Modified	_____	_____
Total Enclosed	_____	_____	Unrestored	_____	_____
			Thoroughbred	_____	_____
			Retired	_____	_____
			Late Model (1974-up)	_____	_____
			Club Affiliation, if any	_____	_____

Number Attending Hospitality Party _____

Mail Payment To:
Gulf Coast Region MCA
P.O. Box 10126
Pensacola, FL 32524

For Additional Information:
Donnie Cartise (904) 455-6588
Rodney Brown (205) 947-4180 (Judging)
Sue Carlisle (904) 455-6588 (Registration)

I agree to abide by all rules of the show and understand that I am responsible for my car and merchandise. I agree to release from all liability, The Mustang Club of America, Gulf Coast Region Group, Hampton & Holiday Inns, University Mall, Merchants Assn. and Corporate Property Investors for any damage, injury, lost or stolen merchandise from this event.

Signature _____ Date _____ Phone _____

Student's Persistence Finally Pays Dividends: He Finds Red Mustang

Most Mustang enthusiasts know what they want when they make that final decision to buy a Pony.

For some it's a convertible. For others it's a Cleveland or Windsor engine. Still others won't accept anything but a Boss. Many of the well-heeled wouldn't consider looking at anything but a Shelby.

But when Michael Spice of Elmwood Park, IL decided it was time to buy that Mustang he had wanted for years, he had one criteria: it had to be Scarlet Red with a white top and white leather interior.

"I remember the first '87 Mustang GT I saw in this color scheme. I knew then and there I had to have that car."

But finding it proved to be a grueling endurance test.

"I read through every issue of *The Chicago Tribune* for several years trying to find that specific Mustang GT. I came across a lot of Mustangs in my three years of searching, but not many had the color scheme I wanted for a price I could afford. Every time I found one with the right colors, the price was out of my reach."

The search finally became so frustrating Michael (MCA Member #24593) was on the verge of giving up hope and he began looking at the 1990 Mustang GT hardtop.

"I started looking for a '90 toward the end of the production year and I wasn't able to



Michael Was On The Verge Of Giving Up His Search When He Discovered The Right Mustang

find what I was looking for in that car either. I just kept searching the dealers around the area."

In September of 1990, Michael discovered he had been looking in the wrong places.

"I was on my way home from college one day when I saw a 'for sale' sign sitting in the car I was looking for. But it wasn't at a car lot. It was at a boat dealership."

Of course! Where else would one expect to find that coveted Scarlet Red '87 Mustang GT?

"When I got home my father and I talked to the manager of the dealership and found out he had taken the car in as a trade for a boat. I thought the Mustang had to be at least an '89 from the cleanliness and overall condition, but the manager of the dealership said it was an '87 with only 25,000 miles on it. We looked a little closer and, sure enough, it was the '87 I had been waiting for."

And even though he had spent years looking for that particular Mustang GT, Michael didn't lose his head and throw common sense to the wind.

"My father and I looked at the car for many days and checked it out from top to bottom before I finally decided to buy it. We were amazed at the condition of the car. Everything was clean. The top was as white as a ghost and the interior — white leather with red trim — didn't even have a scratch. The underside of the car was as clean as a new one."

Better yet, the price was right.

"The price for the Mustang was so low I didn't even have to take out a loan. I would have had to borrow money to buy that new Mustang, but now I had found my dream car and was able to buy it out right."

Michael is still continuing his college education, but he drives to school every day in his Scarlet Red '87 Mustang GT.

Michael Spice of Elmwood Park, IL spent years waiting for his Scarlet Red Mustang with white top and red leather interior.



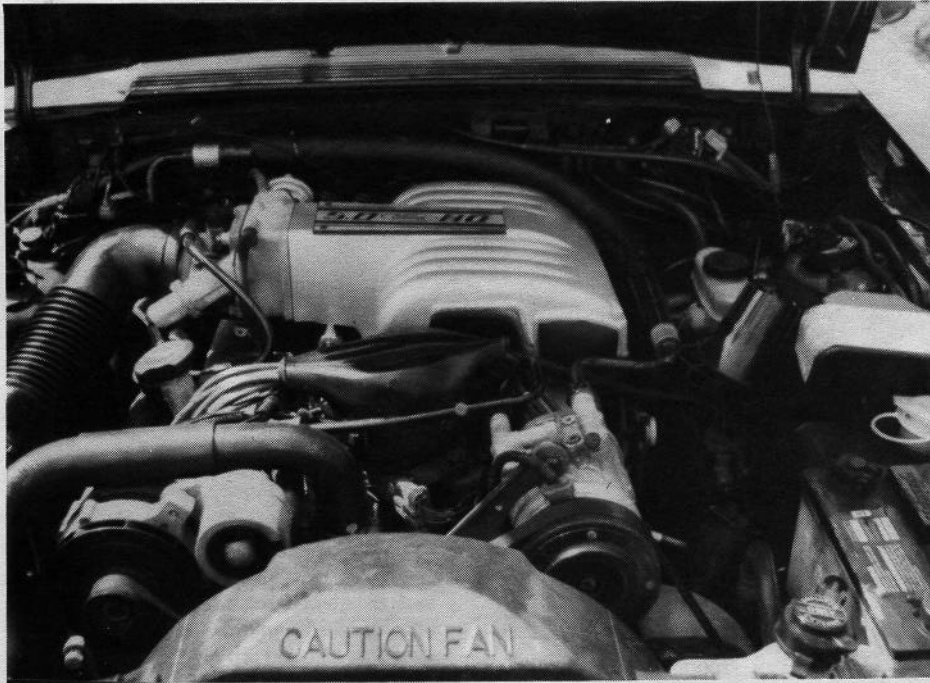

In addition to the interior that met his specifications to a tee, Michael's '87 GT has power windows, power locks, power mirrors, power top, power trunk, tilt wheel, cruise control, premium sound, automatic transmission and air conditioning. It's powered by a 5.0L HO 302 engine.

"There were a few things I wanted to get for my Mustang — such as the running horse found on the dash of newer Mustangs — so I went to Chicago Mustang where I purchased the dash emblem. When the people at the store saw the car they guessed it to be a 1989 or newer. They were truly surprised when I told them it was an '87 and they agreed it was one of the cleanest they had ever seen.

"My friends think the car is new, but I like to keep them guessing. I plan to keep my Mustang all stock and I hope to keep it in the great shape that it's in today."

And he has a few kind words for the guy who traded the Pony for a boat.

"I hope he's enjoying his cruises on the lake as much as I'm enjoying cruising in my Mustang!"

Donna's Dream Is Now Mom's Pride And Joy

Most 16-year-old girls can't wait for Daddy to buy them a car. But in Donna Smith's case, she had to wait for Dad to build her one.

"As soon as Donna turned 16 we went out shopping for cars," says mom Shirley. "She wanted a Mustang, and the first one we came across needed a lot of work.

"It was primered gray and needed a radio and speakers and it had only one seat — the driver's seat," Shirley said.

But the 289 engine was good and the '66 Pony had a four-speed, which daughter Donna had requested.

"Needless to say, as soon as she set eyes on it that was the one she wanted."

But she still had to convince Dad.

"He took a look at the car and decided it needed too much work. But that didn't discourage Donna. She wouldn't even look at another car."

And so Dad wound up in the garage.

"Since then we've put a lot of money and my husband's time into the car. He's done most of the work on it. And, with her few fender benders which came as a result of her learning to drive, we have a few more dollars in it than we could ever get back, what with the repainting of the entire car after every accident."

And, eventually, Donna moved up to an '87 Mustang GT convertible with five-speed ("red with a black top," Shirley says), so

Mom says, "I've decided to keep the Mustang and enjoy it."

Does anyone suspect a conspiracy here?

Shirley (MCA Member #25340) is now the secretary of the Mustang Club of Las Vegas and she says, "I'm having a good time showing the car in car shows in town and just driving it around town."

The Grabber Blue Pony has a white stan-

dard interior and very few options. Shirley runs American Racing wheels with Goodyear Eagles.

"Now that Donna has the GT, I've decided to keep the '66 and enjoy it," Shirley says. "I'm just going to be saving it for Donna's future years."

Okay, Mustangers, now do you suspect a conspiracy?



A Mustang Needs A 'Running Horse', '87 Owner Decides

Late model Mustang owners who have attended MCA and Regional shows throughout the South and West in recent years know Barbara Davenport well. Many of them have had the unfortunate experience of having to try to compete with her 1987 Mustang GT, which has claimed nearly 20 trophies since she purchased the car.

But when Barbara first bought her dark blue Pony, she knew immediately that it was missing something.

"The later new Mustangs have no running horses on the exterior of the car. What's a Mustang without a running horse emblem?"

She told her husband, Bob, something had to be done.

"It's just not right. We've got to do something," she complained.

Bob thought it over and came up with an idea.

"He said we should install a running horse in the grill. He made the horse and put it in the Ford logo, located right on the front of the car. Now I get more compliments on the car and the horse than I ever would have imagined."



With Bob's minor "modification" complete, Barbara (MCA Member Number 18510) decided her 5.0 liter GT was perfect.

"I drive it every day, but I also really enjoy showing it. I really do drive it to work five days a week. A Mustang is to be enjoyed, and the only way to enjoy a classic — even a late model classic — is behind the wheel."

Bob and Barbara have been active Mustangers for many years. The Port Neches, TX couple was instrumental in the

recent formation of the newly-chartered Rainbeaux Mustangers, a group which became affiliated with MCA in early 1991.

"We've got a really enthusiastic group of people," says Bob, who is president of the club. "And we are 100 percent family oriented. We all enjoy showing our cars, but our club believes in planning many other activities that involve the whole family. We have all sorts of weird contests, picnics, caravans and outings and word about our club has gotten around, because we've been



growing very fast. We make sure we stay busy and stay together to talk about and enjoy our Mustangs."

Barbara has been showing her '87 since she purchased it and she says the trophies are just a "added benefit."

This past August, at the 1991 MCA Grand National in Kingsport, TN, Barbara decided to retire her '87 — the first late model to receive that distinction from MCA.

"That doesn't mean I'm tired of showing it, but I thought it deserved a little rest," she says.

She adds that she feels her success at local, regional and MCA shows had a lot to do with that running horse.

"I feel like the horse we installed has helped the car in winning. Most of the trophies have come in the popular vote division, and I think the horse emblem had a great deal to do with that. I know people really do notice it.

"But even if they didn't, I wouldn't care. A Mustang just isn't a Mustang without a running horse. And now that my '87 has one, I'm as happy with it as anyone who ever owned a Mustang."



Barbara Davenport's 1987 Mustang GT, which she uses as a daily driver, has won more than 20 trophies at local, regional and national Mustang shows. The Port Neches, TX Mustanger had her late model retired at the 1991 MCA Grand National in Kingsport, TN last August.

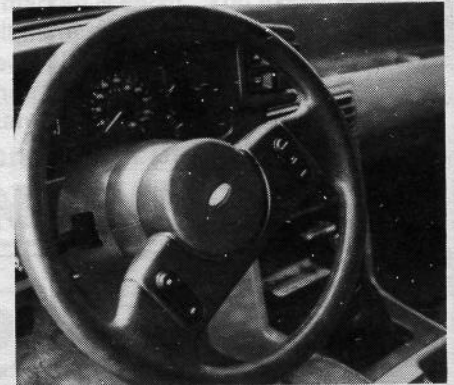
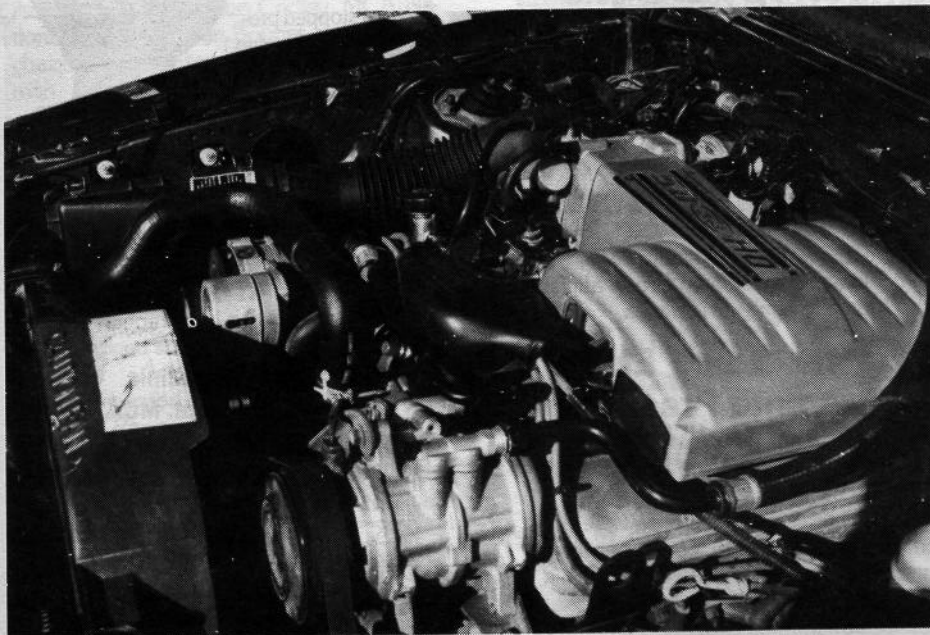

Barbara Davenport of Port Neches, TX discovered that her 1987 Mustang GT didn't have a running horse emblem on the exterior, so husband Bob came up with the idea of installing one inside the Ford logo on the front grill. Barbara says a Mustang just isn't a Mustang without that running horse!

NOW ORDER TOLL FREE!
(800) 888-1MPC
 For Info & Answers Call:
(214) 262-8171



1965-73 Decals	1965-73 Carpet	Headliners \$25/ea.
Gadget bag \$12/ea.	Trunk Mats \$17/ea.	1965-68 Door Panels
Weatherstripping Kits	Owner's Manuals \$5/ea.	1965-73 Upholstery Kits
Jack Pack plaid \$4.00/ea.	Tire Cover plaid \$8.00/ea.	Wiring Diagrams \$4.95/ea.
Chrome Export Brace \$57.50	Black Export Brace \$45.70	1965-73 Heater Cores \$30.00
1965-73 Rechromed Bumpers	1965-66 Armrest Pads \$7.50/ea.	1965-66 Armrest Bases \$5.00/ea.
1971-72 Pop Open Gas Cap \$80.80	1965-73 Rear Leaf Springs \$79.00/ea.	1965-66 Window Regulators \$29.00/ea.
1965-68 Kick Panels	Battery Tray 1965-66	1967-68
1971-73	Convertible Top Repair Manual	Shop Manual 1965-68
Floor Pans, Front 1965-70	Rear 1965-70	RH Battery Apron 1965-66
1967-68	LH Apron 1965-68	Instrument Cluster Bezel
1965 Black Camera Case	1966 Black Camera Case	1965-66 Woodgrain
1967 Black Camera Case	License Plate Frames 1965-73	Interior Lacquer Paint
Interior Vinyl Die	Pony Kick Panel Chrome	Radio Bezels 1967-68
1969-70 Black	1969-70 Woodgrain	Lower A-Arm w/Ball Joint 1965-66
1967	1968-70	Coil Spring 1965-66
1967-68	Vinyl Top Chrome 1965-66	Vinyl Top Chrome 1967-68
Spring Saddles 1965-73	Taillight Bezel 1965-66	Taillight Lens 1965-66
Taillight Body 1965-66	Vinyl Tops 1965-73	Watersheds 1965-73 Coupe/Conv.
1965-73 Fastback	Drip Rail Mouldings 1965-68 Coupe	Dash Pads 1965
1966	1967-68	1969-70
1971-73, Black	Windshield Weatherstrip 1965-68	Rear Glass Weatherstrip 1965-68 Coupe
1965-70 Fastback		

Prices subject to changes w/o notice
 Add 10% for Shipping and Handling
 (Minimum \$2.00)

FREE CATALOG

MUSTANG PARTS CORRAL of TEXAS

New Location

P.O. Box 210524, Dallas, TX 75211
 2100 E. Main St. #4A, Grand Prairie, TX 75050

Oklahoma Mustang Club Members Claim Trophies

Several members of the Mustang Club of Oklahoma received trophies recently in various car shows held their area.

Bill Blundell, Ray and Helen Harris, Alvin and Josie Hendricks and Bobby and Smitly Smith won trophies at a recent Thunderbird Show held in Oklahoma.

The Harrises; Steve, Gian and David Keller; and Joe, Rose, Valerie and Vincent Miller also won trophies at the Green Country Classics Cruise to Hot Springs.

Robert and Sunshine Dudgeon, Alvin Hendricks, Steve Keller and Bob and Denise Mollohan were among the winners in a car show held recently in Clinton, OK.

Participating in the Toys for Tots Cruise-In were Arley Childers, Robert Dudgeon, the Harrises, the Hendricks, Steve Keller, the Mollohans and the Smiths.

The Oklahoma Mustang Club is based in Edmond, OK and is a Regional Group affiliate of MCA.

Sandhill Regional Club Enjoys Holiday Festivities

Members of the Sandhills Regional Mustang Club of Fayetteville, NC participated in two Christmas-related activities during the holiday season.

On Dec. 17, two dozen members of the club attended a Christmas party and supper at Captain Jim's Seafood Shack.

On Dec. 21, several members of the club delivered toys, clothing and food to two local needy families.

"The expression of appreciation by the children and adults alike was very rewarding, proving that it is better to give than to receive," said Archie R. Outland, Jr., MCA National Director for the Sandhills Mustang Club.

Mid-Mississippi Mustangers Elect Officers For New Year

Irv Clack has been elected president of the Mid-Mississippi Mustang Club for 1992.

Serving with Clack during the coming year will be Billy McDaniel, vice president; Susanne Dalton, secretary-treasurer; Kim Barnes, MCA National Director; and Horace Yarbrough, parliamentarian.

The Mid-Mississippi Mustang Club, based in Jackson, is a Regional Group affiliate of the Mustang Club of America.

Rochester Group Elects Joe Quaranto President

Joe Quaranto has been selected president of the Shelby Mustang Club of Rochester, NY for the coming year.

Elected to serve with Quaranto were Bob Allen, vice president; Tim Yorks, treasurer; Donna Allen, secretary; and Tom Zgrodnik, newsletter editor.

Sue Zgrodnik, Mike Keller and Quaranto

were also elected to the MCA Regional Group's Board of Directors.

Named to appointed positions by the group were Allen, Car show Chairman; Quaranto, Watkins Glen Event Coordinator; Tom Zgrodnik, SAAC representative; Ron Faser, membership chairman; and John Upton, data coordinator.

Twin Tiers Regional Club Re-Elects All '91 Officers

The Twin Tiers Regional Group of New York has re-elected its entire slate of 1991 officers to serve during 1992.

Blaine Overacker will remain as president. Serving with him will be Larry Waxman, vice president; Barb Clark, secretary-treasurer; and Craig Miller, newsletter editor.

Mustangers Are Joining '92 DriveAmerica Event

Numerous MCA Regional Groups will join the 1992 March of Dimes DriveAmerica event, to be held this April.

Ford Motor Company is co-sponsoring the '92 fund raising effort, which coincides with the 20th Anniversary WalkAmerica campaign.

"Last year was the first year that DriveAmerica was added to our WalkAmerica event, and we were pleased with the response," said Eugene H. Wilson, Communications Director for the March of Dimes Foundation, Delaware County Chapter, Falson, PA.

Mustang Owners!!!

Jesser's Auto Clinic is offering distinctive keys especially made for your Mustang. Jesser's found the 10-karat white gold plated keys by accident (the original manufacturer stopped production 17 years ago.) and negotiated a deal to get the entire remaining inventory. Supplies are very limited, and when the keys are gone... they're gone!

\$12.50 plus \$2.00 S&H per key
 Matching leather key fob \$9.95
 Ohio res. add 5.75% tax

- Specify year
- Please include phone number

Jesser's Auto Clinic
 26 West Street dept. MCA
 Akron, Ohio 44303

Phone orders 7 days, 9 a.m. - 9 p.m. EST
 Orders can be sent C.O.D.



(216) 376-8181



10 day money back guarantee

NOS & other collectable keys available

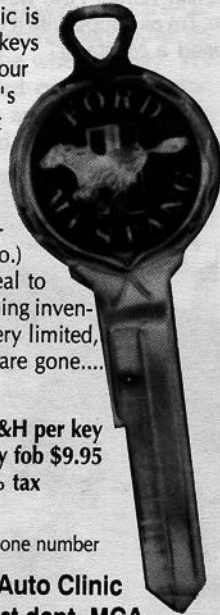

Michiana Mustangs Name New Officers For 1992

The Michiana Mustangs of South Bend, IN have elected Bob Christena president for 1992.

He will also continue to serve as club historian.

Myra Barber will serve as vice president of the MCA Regional Group and Carl Kindig was re-elected treasurer.

Nancy Merrick, immediate past president, will continue as newsletter editor.

David Stribling Elected To Lead Indy Mustangers

David Stribling is the newly-elected president of the Mustang Club of Indianapolis.

Serving with Stribling during 1992 will be Jim Cunningham, vice president; Teresa Miller, secretary; and Peggy Jones, treasurer.

Merrill Miller and Clarence Thompson will join Dan Bohart, Steve Jones, Jim Merrick, Doug Hvidston, Sandy Kosky and Bob Coulston on the board of directors.

The Mustang Club of Indianapolis will host the first MCA National Show of 1992 June 27-28.

John Adams Re-Elected By Front Range Group

The Front Range Mustang Club of Colorado has re-elected John Adams president for 1992.

Other officers elected by the MCA Regional Group include Jack Dore, vice president; Al Sibson, secretary; Donna Adams, treasurer; Leon Cooley, MCA National Director; Bryan Bonner, membership chairman; and Steve Bryant, event chairman.

Shirley Sibson will serve as newsletter editor for 1992.

Virginia Mustang Group Holds Successful Show

The Southeastern Virginia Mustang Club held a car show Oct. 12 in the parking lot of the Freedom Ford dealership in Norfolk.

The judged show drew approximately 35 entries.

Bill Livingston won "Best of Show" with his 1965 Rangoon Red Mustang fastback.

Prizes were awarded throughout the day to those who registered. Owners of the cars with the most votes in each class received trophies.

"Everyone had fun showing their vehicles and we look forward to our next classic car event," said Jim Pletl, National Director of SEVMC.

Updated Information Needed On Certified Judges

Newly-appointed MCA National Head Judge Ricky Simmons has requested that all certified MCA judges provide him with updated information on their addresses and telephone numbers.

"We are making an effort now to compile a correct and comprehensive list of all MCA members who are certified judges. Our

records have not been updated in quite some time, so we need the assistance of our certified judges to help us update our files," Simmons said.

He asks that anyone who is a certified judge submit their name, current address, phone number and class to him at P.O. Box 387, Demorest, GA 30535 by March 31.

FREE SAMPLE ISSUE

Here is the automotive source you've been looking for—the

Ford Buyer's Guide

with its valuable marketplace for Mustang car and parts. Throughout the pages of the monthly magazine, you'll find useful information on buying, selling, restoring and customizing your Pony; a calendar of events and swapmeets; new products on the market and aftermarket; and a money saving network of mail order new, used and reproduction parts. And, you can sample a current issue FREE.

SEND NO MONEY. Just call our toll-free number and ask for the Ford Buyer's Guide. We'll send your free issue; **NO COST, NO OBLIGATION.** If for any reason, you don't like the issue, just return your invoice for the next 11 issues (a full year subscription) marked "cancel." You'll be under no further obligation and the complimentary issue is yours to keep.

All of this yours for the low subscription rate of \$16.95 for 12 action-packed issues, less than \$1.42 per issue. A savings of over 43% off the newsstand price.

For Faster, More Convenient Delivery

CALL NOW!

FORD BUYER'S GUIDE

"For the serious performance and restoration enthusiast."

Subscribe Toll-Free
1-800-435-0715

Weekdays or evenings
7:30am-10:30pm CST

SUBSCRIPTION DEPARTMENT: P.O. BOX 1964, MT. MORRIS, IL 61054-8092

Braves Parade Is A Nightmare For Ga. Regional

By KITTY WILMOT
Assistant Editor

Atlanta baseball fans had to wait a quarter of a century for their Braves to make an appearance in the World Series, and when that day finally arrived last October, the city literally went wild.

But the euphoria of a quarter-of-a-million baseball fanatics who swarmed world-famous Peachtree Street Oct. 29 for a parade celebrating the success of the home team turned into a nightmare for members of the Georgia Regional Mustang Club and the Southeast Camaro Club.

The two classic car groups had been invited to participate in the celebration — using their prized collectible cars to transport city and team officials and players along the route while ecstatic fans cheered their heroes.

Unfortunately, the 250 police officers the city assigned to handle security for the event were swallowed up by the unexpectedly large crowd of 750,000 parade-goers.

The result was significant damage to a number of Mustang and Camaro convertibles, hundreds of complaints from fans whose feet were run over during the parade, and a nightmare of paperwork for local insurance agents.

Members of the Georgia Regional Mustang Club who had been asked by city officials to participate in the parade arrived at the site about two hours prior to the scheduled starting time.

The parade began with convertibles carrying the mayor and members of the Atlanta city council and these classic cars were



followed by Mustangs and Camaros transporting members of the team.

All went well until MCA Board Member Tom Gattis came through in his beautifully restored 1965 Mustang, carrying two Braves stars — outfielder David Justice and second baseman Mark Lemke.

Jubilant fans swarmed Tom's car — a photograph in a local newspaper showing the rear of the Mustang depicted a crowd so thick that all that was visible was a portion of the rear bumper.

From that point on, the parade went downhill. The crowd was so heavy that many of the convertible drivers later said they knew they had rolled over hundreds of feet that day. Several of the cars overheated due to their inability to move through the throng.

But the worst part was the damage done to some of the nicest Mustangs and Camaros in Atlanta.

The cars in front of Gattis fared pretty well, with only minor damages, such as broken antennas and minor paint scratches. But some of the cars at the end of the parade were severely damaged. April Craft's 1971 Mustang — which is featured in the MCA 1992 Calendar — sustained \$4,200 in damage and Jack Yeager's 1971 Mustang suffered more than \$2,500 in paint damage alone.

One member, Sandy Kitchens, was nice enough to bring out three cars, a 1967 Mustang, a '68 Camaro and a '91 Camaro Z-28. All three sustained heavy damage.

Not only were the spectators out of control, the media was not much better. One TV cameraman tried to climb on the whale tail of Bill Koivu's 1988 Saleen to get a shot of Cy Young Award winner Tom Glavine. Another member literally hit this cameraman with his 1968 Shelby to get him away from the cars.

Even the Braves' family members were upset. There were several with small children who were terrified and one player's pregnant wife was admitted to the hospital later that night with labor pains.

As Georgia Regional President Bob Deale said, "During the parade I thought I was going through the greatest experience of my life since I returned from Vietnam. Unfortunately, now I am dealing with attorneys and the damage claims of our members. It has really been a big let-down."

Georgia Regional has participated in numerous parades, including the Macy's parade, and we have never experienced any problems. But this parade was totally out of control. Let this be a warning to all our regional groups. If you plan to be in a parade, make sure the security is adequate or you might be repairing your Mustang.

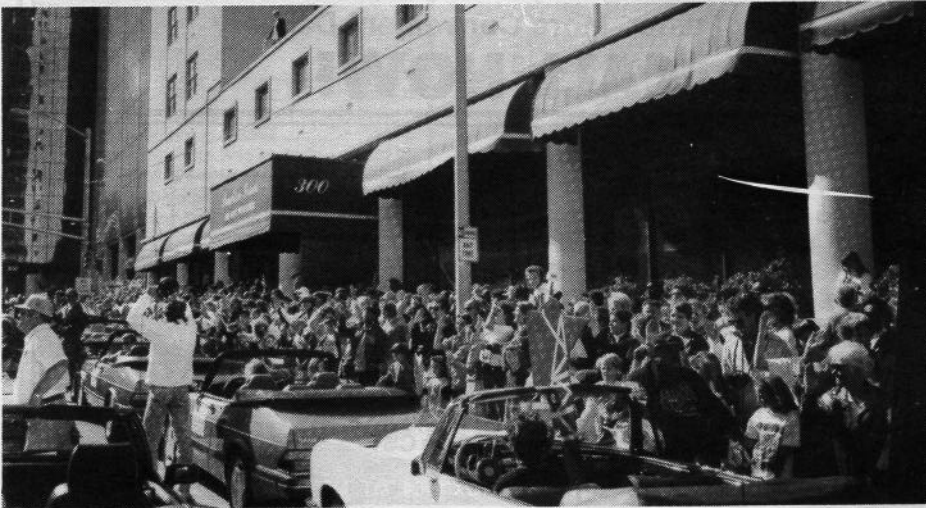

Southern Illinois Club Holds Annual Round-Up With 104 Cars Judged

The Southern Illinois Mustang Association held its 14th consecutive annual Mustang show recently with 104 cars in attendance.

"During the past 14 years we haven't missed a year holding a Mustang show, and each one has been a bigger success than the one before," said Walter Rudolph, publicity chairman for the MCA Regional Group.

"Not only was the 1991 show the largest we've ever held, we added eight new members to our roster, bringing us up to 52 members.

"The weather was fine and the cars were some of the best in the midwest. We hope to have a National show someday, but in the meantime we're happy to have so many hard working members in our club to make all of our activities a huge success.

"We sincerely appreciate the efforts of our club members who helped us put on our 1991 show and we want to especially thank those who brought their classic Mustangs to our annual event."

Bob Roden is president of the Southern Illinois Mustang Association.

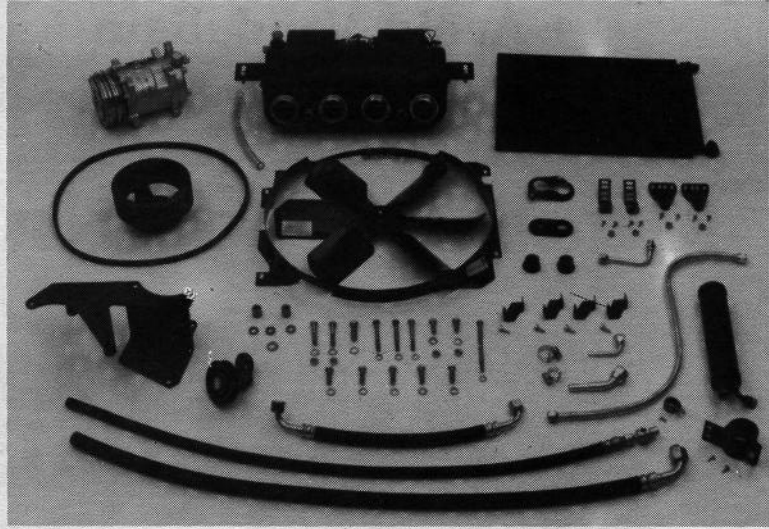

Daily Driver AC System Introduced

Classic Auto Air Manufacturing Company has announced the availability of an alternative to its "all original factory air system for 1965-66 Mustangs." Called the daily driver system, it is virtually identical to the original, according to a company spokesman. A new compressor, mounting and high output underdash unit is used in place of the rebuilt original components. For detailed information contact Classic Auto Air Manufacturing Company, 2020 West Kennedy Boulevard, Tampa, FL 33606.

Now Available!

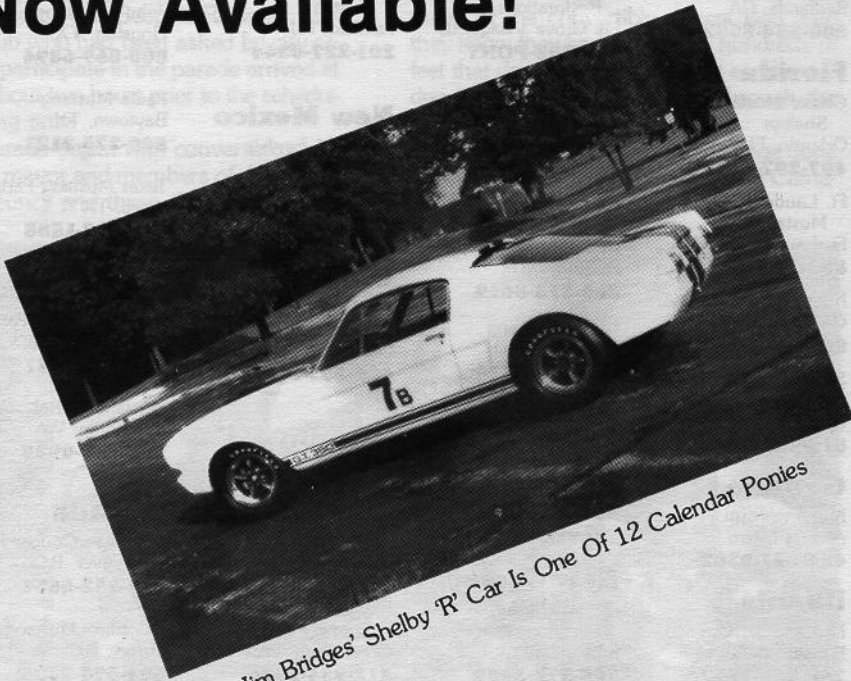

Jim Bridges' Shelby 'R' Car Is One Of 12 Calendar Ponies

MCA's Official 1992 Calendar

The Mustang Club of America's Official 1992 Calendar is now available for purchase.

The 1992 edition includes 12 full-color photos of some of the most outstanding early and late model Mustangs in the nation.

This collector's item also features key dates in 1992 for MCA events, including National and Grand National Shows.

The 1992 calendar is available for \$8.00 plus \$2.00 shipping and handling and will be sent to you via First Class Mail upon receipt of your order and payment.

To order your 1992 calendar, send check or money order to:

MCA 1992 Calendar
P.O. Box 447
Lithonia, GA 30058

All Chrome



Made in U.S.A.

- Avoid Vandalism
- Flip-up Latch Reveals Key Insert

Mustang Locking Gas Cap



Pat. Pending

for your
**1965 to 1970
Mustang**

(except GT, Mach 1, and Shelby)

This part is not
Ford Motor Co.™ original
or 'NOS' part.

Now Available At The Following:

California

All American
Mustang of
California
Lake Isabella, CA
800-266-0289

American Mustang
Rancho Cordova, CA
800-824-6026

Beebe's Mustang
Fallbrook, CA
800-752-4577

Fresno Mustang
Fresno, CA
209-486-4794

J & K Mustang
Sacramento, CA
916-332-1872

Larry's T-Bird
& Mustang
Fullerton, CA
800-854-0393
800-698-2473
(In Calif.)

Mustang City of
Belmont
Belmont, CA
415-591-3313

Mustang Country of
Paramount
Paramount, CA
213-633-2393

Mustang Mart
Campbell, CA
408-371-5771

Mustangs Only
San Jose, CA
408-453-1077

National Parts Depot
Ventura, CA
800-235-3445

Sacramento Mustang
Sacramento, CA
800-442-8333

Scott Drake Mustang
Camarillo, CA
800-999-0289

The Mustang Shoppe
San Diego, CA
619-281-8173

The Paddock
Redlands, CA
800-854-8532

Florida
Classic Mustangs &
Shelbys
Orlando, FL
407-297-6109

Ft. Lauderdale
Mustang
Ft. Lauderdale, FL
800-321-1965

National Parts Depot
Gainesville, FL
800-874-7595

Sunstate Pantera
Parts
Largo, FL
813-584-0241

Georgia
Mustang Farm
Atlanta Metro, GA
404-427-0382

Illinois
Mustangs of Chicago
Bensenville, IL
708-860-7077

Mustang
Restorations, Inc.
Elk Grove Village, IL
708-298-PONY

Indiana
The Paddock
Knightstown, IN
800-428-4319

Maryland
Dad's Mustang Supply
Fallston, MD
800-373-8619

Laurel Mustang
Columbia, MD
800-368-9314

Michigan
National Parts Depot
Livonia, MI
313-591-1956
800-521-6104
(out of state)

New Jersey
Central Jersey
Mustang
Edison, NJ
908-572-3939

Garden State
Mustang
Fairfield, NJ
201-227-0364

New Mexico
Route 66 Service
Center
Albuquerque, NM
505-268-1588

Oklahoma
Mustang Parts of
Oklahoma
Oklahoma City, OK
405-631-1400

Oregon
Rose City Mustang
Portland, OR
503-243-1938

Pennsylvania
Pittsburgh Mustang
Supply
Greensburg, PA
412-834-2226

Texas

John's Mustang
Houston, TX
800-869-6894

Paul's Mustang
Baytown, TX
800-275-2121

Texas Mustang Parts
Waco, TX
800-527-1588

Washington
American Pony Parts
Lynnwood, WA
206-771-4447

Mustang Corral
Burlington, WA
206-757-0930

Canada

Canadian Cougar Parts
Vancouver, B.C.
604-432-6664

Canadian Mustangs
Surrey, B.C.
604-594-2425

Mustang Locking Gas Caps
Dealer Inquiries — 800-247-5432

Reader Questions Carburetor In His '70 Boss 302

Dear Fred:

I am near the completion of a restoration project on my 1970 Boss 302. The question concerns the carburetor. The numbers on the air horn read:

DOZF-9510-Z
LIST 4653
A 2215

Is this carburetor correct for my car?

John

Dear John:

The carburetor is "correct" — but not an original factory unit.

DOZF-9510-Z is the correct Ford Engineering number. When referring to Ford numbers, usually the prefix "DOZF" and suffix "Z" are used and the "9510" is omitted — 9510 is the Ford group number for all carburetor assemblies, one, two or four barrel.

The "List 4653" is Holley's part number. In the lower left corner of the air horn the letter "A" refers to design change level. "A" indicates original calibration and associated parts. If some slight modification was made during the model year, the letter would be B, C, D, etc.

The four digit number in the lower right corner of the air horn is the date code. All factory installed Ford carburetors had three digit date codes. The four digit code signifies an aftermarket unit from Holley.

The four digit code is a "Julian" date. The first three characters are days of the year (001-365). The fourth character is the year. This is the date the carburetor was manufactured.

Your carburetor date, 2215, would be the 221st day (30 July) of 1975 or 1985 (probably 1985).

With an original factory carburetor code, for example, C80F-AA, date code 834, we know that the year this unit was first used is 1968 by the "C8" (1970 would be DO, etc.) The date code is read year/month/week, 834 equates to 1968/March/fourth week.

Fred

Dear Fred:

Six months ago I bought a 1967 Mustang coupe which is driven daily. When I purchased the car, it had all four original wheel covers.

Recently the front covers fell off and were lost, requiring replacement. Once again they fell off, repeating the problem.

As you know, this can be expensive. When I put them on, they feel sufficiently

The Mustang Times/February, 1992

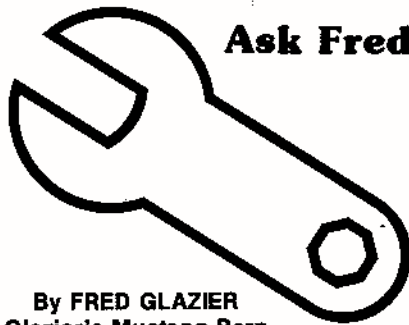

By FRED GLAZIER
Glazier's Mustang Barn

tight that they could not possibly fall off. I have tried everything, such as bending the prongs and making sure the cover was installed fully. I have also looked for hub cap locks, but cannot find anything appropriate.

I would greatly appreciate any suggestions for resolving this aggravating problem.

Jason Stovall

Dear Jason:

You have one of those problems which can be difficult to diagnose in absentia. However, there are a few things you can do.

The most likely answer is that the front wheels are not correct. The wheels used by Ford came from various manufacturers, and on some the "flat" area which the wheelcover grippers rest upon actually "slopes" outward, so that even though the wheelcover feels tighter than normal, the gripping surface will not hold. If this area is "flat," examine the condition of the surface. If it is badly scarred from long use, careful surface grinding to restore a smooth appearance will often help. Be careful to remove as little material as possible or the wheel will be weakened.

Bending the grippers is a tricky procedure. These are designed to work best at a certain engaging angle, and if this geometry is disturbed, they may not grip no matter how tight they feel.

One remote possibility is if your wheels are badly out of alignment, wheel flex could cause the covers to fall off. You would probably already have noticed this, however.

Fred

Dear Fred:

As a charter subscriber to *The Mustang Times*, I have read and enjoyed your *Ask Fred* column.

I own two Mustangs, a 1964½ convertible and a 1965 convertible.

My question concerns the '65.

It is in excellent mechanical condition, and is Springtime Yellow with a black top and black interior.

I never liked the color, but purchased the car, with all the original paperwork, because I knew the original owner and knew that the car had been garaged since new.

The car now needs some minor interior work, and exterior paint.

I am considering changing the color to white with a red interior, or red with a red interior.

I do not plan to show the car, but rather to continue daily use.

I would appreciate your comments on both the color change and which of the two colors would be more appropriate and would hold the resale value of the car.

William C. McDade, MD

Dear William:

I cannot say which of the two colors would hold the value of the car, because neither would.

You have a well documented original car, apparently in good condition. Given the "provenance" of your documentation, and the evidence of the original warranty plate, the value of the car would be diminished by the cost of returning the paint or interior to the original color.

Fred

Dear Fred:

I own a '65 fastback. I just purchased a used, early-style Rally-Pac which has two wire harnesses coming out of it. Each wire has a plug on it and is in great condition.

I have a question: Do I need another wiring harness that goes from the ones on the Rally-Pac to under the dash or do the ones already on the Rally-Pac plug in under the dash?

I would really appreciate your help on this.

Tony Spataro

Dear Tony:

Yes, there is a separate wiring harness required to attach your Rally-Pac leads to the under-dash (main) wiring harness, which can be obtained from a number of sources.

Fred

Have a problem for Fred? Send your question to: "Ask Fred," C/O *The Mustang Times*, P.O. Box 448, Lithonia, GA 30058.

Anniversary Edition Celebrated Mustang's 20th Year

By RANDY CHURCH

Late Model Gold Card Judge

"Twenty years ago, the first Mustang rolled off the assembly line and triggered the most spontaneous public demand in automotive history.

"A Legend was born overnight."

—Quoted from Ford Program Brochure, 1984.

Introduction of the 1984 20th Anniversary Limited Edition Mustang followed an advertising campaign "guaranteed to build 'Remember when ...' nostalgia and 'High Tech ...' excitement."

Ford chose to unveil the eagerly-awaited 20th Anniversary Mustang in April to coincide with the April 17th introduction of the original Mustang.

The anniversary car was designed to recapture the overwhelming excitement of the earlier Mustang, which in 12 months had sold a record 417,000 cars and in 2½ years had inspired the formation of 472 Mustang Clubs boasting a membership of some 32,000.

Special features of the 1984 Anniversary Limited Edition Mustang included:

- ✓ White exterior paint with distinctive dark red racing stripes,
- ✓ Original-style Mustang ornamentation on the front fenders,
- ✓ Unique white bumpers and rub strip extensions with a dark red stripe,
- ✓ SVO-type narrow bodyside molding,
- ✓ Black or white convertible top (when applicable),
- ✓ Canyon red cloth articulated sport seat trim (includes adjustable thigh and side bolsters),
- ✓ Distinctive instrument panel badge—20th Anniversary Limited Edition applique and a personalized customer nameplate with the engraved production number of the limited edition.

Between March 5 and March 22, 1984, 5,245 anniversary Mustangs were produced, and 15 Ford VIP convertibles were produced in May, 1984 for a total production of 5,260 cars.

A breakdown of these figures shows there were 350 three-door Turbo GTs, 3333 three-door 5.0 Liter GTs, 104 convertible Turbo GTs, and 1213 5.0 Liter convertible GTs.

Some 245 cars were produced for the Canadian market and an additional 15 convertibles were earmarked as Ford VIP cars.

Standard features included:

- ✓ Dual remote-control styled mirrors,
- ✓ Five-speed manual transmission,

Ford Motor Company OKs New Mustang

The Board of Directors of Ford Motor Company has approved production of the next-generation Mustang and decided that the car will be produced at Ford's Dearborn, MI assembly plant, according to *Automotive News*.

The new Mustang is expected to be introduced to the public by 1994 or 1995.

Ford officials would not discuss details of the new Mustang, but a team of 200 engineers has been working on the new Pony program for more than a year.

Kenneth Dabrowski, program manager for international and small-car programs at

Ford, has been quoted as saying that the new Mustang will continue to be rear-wheel-drive.

Dabrowski has also said Ford would like the new Mustang program to cost about 45 percent less than the average \$1 billion it generally costs to develop a new car program, but has admitted the company would be satisfied with a 20 percent cost reduction.

Ford admits it needs a boost with its Mustang sales, which have been steadily declining and totaled 68,064 at the end of last October, down 36 percent from 1990 figures.

- ✓ Cast-aluminum wheels,
- ✓ Power front disc brakes,
- ✓ Wide bodyside molding,
- ✓ Power steering,
- ✓ Full instrumentation,
- ✓ Handling suspension,
- ✓ Console and low back reclining bucket seats,
- ✓ Traction lock axle,
- ✓ Sport-tuned exhaust.

Available options included flip-up open air roof, T-roof, premium sound system, Select-shift automatic transmission with locking torque converter, air conditioning, speed control, AM/FM stereo cassette radio, interval windshield wipers, tilt steering wheel and electric window defroster.

Base price of the 5.0 Liter convertible was \$13,247. Base price for the 5.0 Liter three-door hatchback was \$9,774. The anniversary package added \$400 to the base price.

Not everyone was pleased with Ford's design choice for the 20th Anniversary Limited Edition Mustang. Carroll Shelby filed suit against Ford for infringement on his trademarked name "GT 350" for use of it on the 1984 Mustang without his permission.

Shelby originally used the "GT 350" designation on the 1965 Shelby Mustang. (Rumor has it that the 350 stood for the number of steps from his office door to his garage door).

The original suit filed by Shelby asked for a \$30 million damage settlement, but was later increased to \$100 million. No one at Ford is commenting, but the unofficial word is that the matter is still "under litigation."

Ford offered a poster celebrating the 20 years of Mustang history as part of its promotion of the Anniversary Mustang. Copies

of that poster are still available from some literature suppliers. They are generally available for about \$15.

As the owner of a 1984 Anniversary Mustang, my enthusiasm for these cars is limitless.

I started a 20th Anniversary Mustang Owners' Association to document ownership of these special cars. After six months, I am amazed at the enthusiastic response from owners of these Ponies.

I have members in New Jersey, Ohio, Illinois, Pennsylvania, Texas, Alaska, North Carolina, Mississippi, Minnesota, California, Arizona, Connecticut, Indiana and three members from Canada.

If you are interested in information about the owners' association, please contact me at 20th Anniversary Owners' Association, P.O. Box 7, Baldwin, GA 30511.

Another unique model Mustang was introduced in 1984. The SVO or "Special Vehicle Operators" Mustang made its debut in 1984.

The SVO featured a 2.3 Liter in-line four-cylinder engine with electronic port-type fuel injection and turbocharger with air-to-air intercooler.

The turbo system was unique in that it included variable computer-controlled electronic turbo boost, which limits low rpm boost to safe levels and permits infinitely variable boost up to 14 psi compared to standard systems with a mechanical boost designed to adjust to maximum boost as quickly as possible, thus restricting boost to a maximum of about 10 psi. Maximum power (as measured by SAE standard J1349) was listed as 175 HP at 4400 rpm.

SVO Mustangs were the only ones to feature functional hood scoops, designed to



The first of approximately 5,000 Limited Edition Ford Mustangs, commemorating the car's 20th anniversary, is shown rolling off the assembly line at the Dearborn, MI Assembly Plant. Since their introduction in 1984, the Limited Edition Anniversary Mustangs have become popular collector cars.

assist in the air-to-air intercooling.

The SVO's five-speed manual transmission had a shift linkage designed by Hurst to produce a responsive feel. A larger stabilizer bar helped keep the car under control over rough surfaces and during hard use. Gas filled/adjustable Koni shocks completed the handling package.

A Traction-Lok rear axle with 3.45:1 final drive ratio was included as standard equipment. SVO tires were "race-proven" Goodyear NCT steel-belted radials. They were VR rated, mounted on 16-inch cast aluminum wheels that were seven inches wide.

Interior design of the SVO featured a multi-adjustable seat, tilt steering wheel, a foot rest located next to the clutch pedal for support of the driver's left foot during right-hand maneuvers, console with armrest and glovebox, and standard premium sound package.

The easy-to-read dials and gauges included a coolant temperature gauge, a turbo boost gauge with 0-18 psi face that worked in combination with an overboost warning light and buzzer, an 8000 rpm tachometer redlined at 6000 rpm, a special speedometer with resettable trip odometer, and oil pressure gauge.

A fuel recalibration switch was located on the front of the console below the radio. This allowed the driver to change from premium to regular unleaded gas with the flick of a switch.

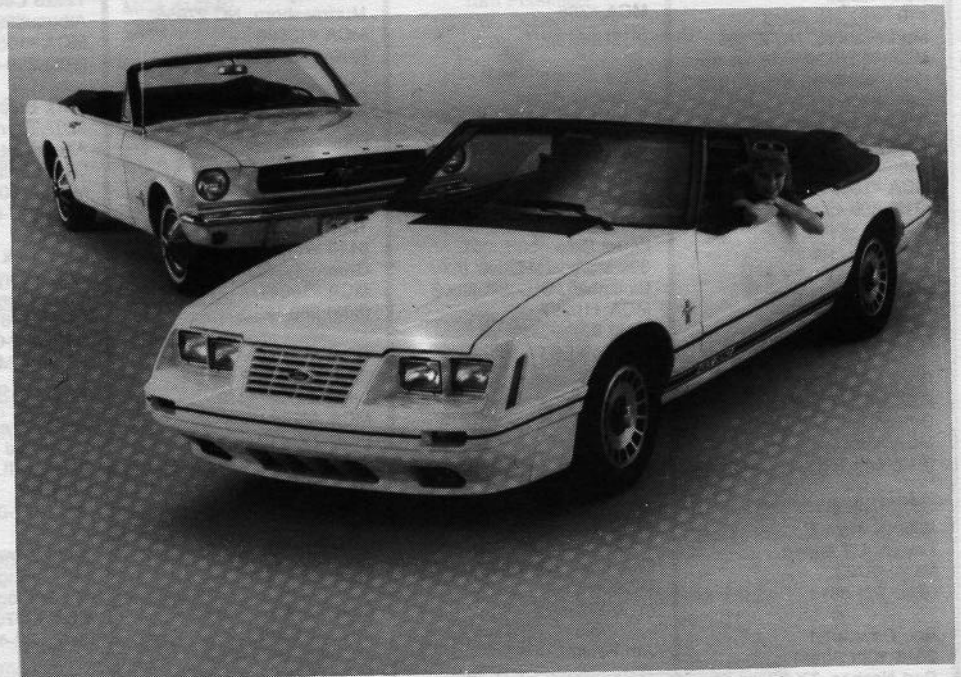

David Larocque, 473 Second Street, Box 164, Espanola, Ontario Canada POP 1CO, has started an SVO Owners' Association. By joining his registry, you will help give a more complete picture of the history and development of the SVO.

He has a comprehensive questionnaire which will help document unique features of the SVO for future collectors.

The first Ford Mustang (background) is shown with a 20th Anniversary Limited Edition model. In the foreground is a 1984 turbo GT convertible. Just over 5,000 of these anniversary Mustangs were produced by Ford Motor Company in 1984.

GOLD CARD JUDGES

1964½-1965

Ray Boismenu
6131 West Beltwest
Belleville, IL 62223
MCA #8673
(618) 235-4634

Bob Deale
29 Brookcrest Drive
Marietta, GA 30068
MCA #17160
(404) 973-3036

Charles Hampton
822 Sharonwood Drive
Anderson, SC 29621
MCA #1230
(803) 225-7260

John Murphy
P.O. Box 845
Pawnee, IL 62558
MCA #7600
(217) 625-7183

Bobby Dodd
Rt. 1, Box 1508
Danville, VA 24541
MCA #4729
(804) 685-3653
6-10 p.m. EST

Don Phillips
410 Holly Hill Road
Murfreesboro, NC 27855
MCA #10730
(919) 398-4405

Barry Phillips
410 Holly Hill Road
Murfreesboro, NC 27855
MCA #13596
(919) 398-4926

Skip Youngdahl
1 Meditation Way
Florissant, MO 63031
MCA #10045
(314) 921-3673

Bobby Summers
P.O. Box 378
Gibsonville, NC 27249
MCA #599
(919) 449-7565

Scott McNair
2250 N 1075 E
Layton, UT 84040
MCA #8723
(801) 771-8611

Bob Davenport
2316 10th Street
Port Neches, TX 77651
MCA #18510
(409) 727-1052

Jack Bosc
7206 Goddard
Shawnee, KS 66203
MCA #16547
(913) 631-2027
6-9 p.m. CST

Johnny Blackston
17 Lawnview Court
Greenville, SC 29611
MCA #22528
(803) 246-7444

Melvin Little
P.O. Box 918
Sapulpa, OK 74066
MCA #6252
(918) 227-0678

Horace Wood
3653 Altadena Drive
Birmingham, AL 35243
MCA #1821
(205) 967-1705

Wally Short
12825 Cedarbrook NE
Albuquerque, NM 87111
MCA #10576
(505) 299-4573 MST

Richard Ciaffredo
1791 Vaila Drive
San Jose, CA 95124
MCA #18779
(408) 448-7241

Fred Glazier
531 Wambold Road
Souderton, PA 18964
MCA #788
(215) 723-9674

Dave Zimmerman
6 Tainter Street
Box 213
Peapack, NJ 07977
MCA #7993
(908) 234-0535
6-9 p.m. EST

Ferrel Buis
399 Maycrest Drive
Cincinnati, OH 45237
MCA #10287
(513) 821-4928
6-9 p.m. EST

John Hall
13222 Laurel Lake Court
St. Louis, MO 63131
MCA #4333
(314) 955-4779

Al Friedel
10423 Lockcrest Drive
Cincinnati, Ohio 45231
MCA #12417
(513) 771-4558

Jim Fannin
1701 Sweetbriar Drive
Bloomington, IL 61701
MCA #18064
(309) 829-3359

1966

Pat Holloway
6403 Oriole Dr.
Lafayette, IN 47905
MCA #20118
(317) 447-1910

Ray Boismenu
6131 W. Belt West
Belleville, IL 62223
MCA #8673
(618) 235-4634

Charles Hampton
822 Sharonwood Drive
Anderson, SC 29621
MCA #1230
(803) 225-7260

John Murphy
P.O. Box 845
Pawnee, IL 62558
MCA #7600
(217) 625-7183

Bobby Dodd
Rt. 1 Box 1508
Danville, VA 24541
MCA #4729
(804) 685-3653
6-10 p.m. EST

Don Phillips
410 Holly Hill Road
Murfreesboro, NC 27855
MCA #10730
(919) 398-4405

Barry Phillips
410 Holly Hill Road
Murfreesboro, NC 27855
MCA #13596
(919) 398-4926

Bobby Summers
P.O. Box 378
Gibsonville, NC 27249
MCA #599
(908) 449-7565

Tommy Gilstrap
6113 Whitehorse Road
Greenville, SC 29611
MCA #16647
(803) 269-1232

Scott McNair
2250 N 1075 E
Layton, UT 84040
MCA #8723
(801) 771-8611

Richard Ciaffredo
1791 Vaila Drive
San Jose, CA 95124
MCA #18779
(408) 448-7241

Melvin Little
P.O. Box 918
Sapulpa, OK 74066
MCA #6252
(918) 227-0678
(918) 224-1121

Horace Wood
3653 Altadena Drive
Birmingham, AL 35243
MCA #1821
(205) 967-1705

John Hall
13222 Laurel Lake Court
St. Louis, MO 63131
MCA #4333
(314) 955-4779

Dennis Havens
1660 Marblehead Road
Clemmons, NC 27012
MCA #9501
(919) 945-3480

Gene Millsbaugh
12725 Brookshire Ave
Baton Rouge, LA 70815
MCA #3799
(504) 275-6460

William Henricks
8000 West 88th Street
Overland Park, KS 66212
MCA #19425
(913) 341-2630
After 7 p.m. CST

Daryl Silvers
38240 W. 151st Street
Eudora, KS 66025
MCA #16543
(913) 882-6202

Wally Short
12825 Cedarbrook Ave.
Albuquerque, NM
MCA #10576
(505) 299-4574

Mark Brockman
2207 Thunder Rdg Blv
Apartment 6A
Cedar Falls, IA 50613
MCA #18068
(319) 277-5340

Luke York
2709 Evergreen Drive
Greensboro, NC 27408
MCA #17870
(919) 632-0079
9-5 p.m. M-F EST

1967-68

Floyd Scranton
61 Ronald Drive
Decatur, IL 62526
MCA #
(217) 877-0604

Junior Downer
145 Rolling Hills Drive
Chattanooga, TN 37343
MCA #3370
(615) 842-4293

Jeff Speegle
1223 Huntington
Manteca, CA 95336
MCA #18053
(209) 239-6050

Don Orlein
720 Milbank Dr.
Modesto, CA 95354
MCA #18749
(209) 527-7217
After 5 p.m. PST

Jim Warren
4912 Reynolds Road
Fort Worth, TX 76180
MCA #9424
(817) 281-4875

Scott McNair
2250 N 1075 E
Layton, UT 84040
MCA #8723
(801) 771-8611

Dave Zimmerman
6 Tainter Street
Box 213
Peapack, NJ 07977
MCA #7993
(908) 234-0535
6-9 p.m. EST

Leonard McCoy
13240 Applewood Dr.
Grandview, MO 64030
MCA #17065
(816) 763-7534

Jim Alderson
R.R. 3, Box 44
Carlinville, IL 62626
MCA #17609
(217) 839-2739.

Farrel Buis
399 Maycrest Ave.
Cincinnati, OH 45237
MCA #10287
(513) 821-4928
6-9 p.m. EST

1969-70

Jack Staples
P.O. Box 61
West Point, GA 31833
MCA #12373
(205) 576-3377

Jim Osborn
101 Ridgecrest Drive
Lawrenceville, GA 30245
MCA #376
(404) 962-7556

Bob Vickery
1470 Stephenson Road
Lithonia, GA 30058
MCA #3411
(404) 482-7044

Jeff Speegle
1223 Huntington
Manteca, CA 95336
MCA #18053
(209) 239-6050

Ron Myska
Box 886
Vacaville, CA 95688
MCA #24134
(707) 447-8367

Steve Ames
4161 Rolling Springs
Tampa, FL 33624
MCA #17269
(913) 962-2936

1971-73

Jack Yeager
4378 Glenhaven Drive
Decatur, GA 30035
MCA #411
(404) 289-3468

Bob Coulston
5716 Bar-Del East Drive
Indianapolis, IN 46241
MCA #15454
(317) 858-6204

Bob Black
9182 N Cherry Hills Dr
Columbus, IN 47201
MCA #9300
(812) 526-9493

Theresa Vickery
1470 Stephenson Road
Lithonia, GA 30058
MCA #3411
(404) 482-7044

Tom Podemski
1526 W. Calvert St.
South Bend, IN 46613
MCA #17084
(219) 289-1920
FAX: (219) 234-5419
Evenings & Weekends

Marvin Scrothorn
6250 Germantown Pike
Dayton, OH 45418
MCA #9145
(513) 866-0690

Franklin Diebert
341 Maxon Road
Lancaster, PA 17601
MCA #11335
(401) 434-1228
6-10 p.m. EST

Shane Bryant
515 Milford Church Rd.
Taylors, SC 29687
MCA #16727
(803) 895-3372

John Stastny
1530 11th Street
Fennimore, WI 53809
MCA #16997
(608) 822-6301
6-9 p.m. CST weekdays

Debbie Ames
4161 Rolling Springs
Tampa, FL 33624
MCA #17269
(913) 962-2936

1965-66 Shelby

Bruce Weiss
731 Workburn Road
Melbourne Bch, FL 32935
MCA #19423
(407) 259-9089

1967-70 Shelby

Jack Staples
P.O. Box 61
West Point, GA 31833
MCA #12373
(205) 576-3377

Charles Hampton
822 Sharonwood Drive
Anderson, SC 29621
MCA #1230
(803) 225-7260

Bob Oswalt
1919 Blue Ridge Terrace
W. Columbia, SC 29169
MCA #3624
(407) 259-9089

Bruce Weiss
731 Washburn Road
Melborne, FL 32935
MCA #19423
(407) 259-9089

Jim Osborn
101 Ridgecrest Drive
Lawrenceville, GA 30245
MCA #376
(404) 962-7556

Bruce Cunningham
19025 Laurel Drive
Los Gatos, CA 95030
MCA #17725
(408) 354-4674

Boss Mustang

Bob Perkins
N. 3183 Highway 26
Juneau, WI 53066
MCA #16859
(414) 696-3788

Ricky Simmons
P.O. Box 387
Demorest, GA 30535
MCA #17874
(404) 778-6329

Bill Dillard
2536 Rome-Dalton Rd.
Calhoun, GA 30701
MCA #7
(404) 625-2677

Bill Weaver
304 Foster Drive
Rocky Mountain, NC 27801
MCA #19098
(919) 446-6639

Jim Osborn
101 Ridgecrest Drive
Lawrenceville, GA 30245
MCA #376
(404) 962-7556

Doug Monroe
797 Brookside Drive
Columbus, OH 43209
MCA #23576
(614) 236-1410

Ed Hockaday
5925 Sovereign
Houston, TX 77036
MCA #21753
(713) 342-0753

Bernie Doty
Box 233
Strasburg, IL 62465
MCA #20433
(217) 644-2873

Jim Cunningham
4920 Willow Road
Zionsville, IN 46077
MCA #5447
(317) 873-5984
After 7 p.m. EST

1974-78

Tom Podemski
1526 W. Calvert Street
South Bend, IN 46613
MCA #17084
(219) 289-1920
FAX: (219) 234-5419
Evenings & Weekends

1974 and Up

Tom Bader
1818 Cairnbrook Drive
Montgomery, AL 36106
MCA #16449
(205) 271-1019

1979-1991

Randy Church
P.O. Box 864
Baldwin, GA 30511
MCA #17916

Modified

Rodney "Shorty" Brown
17930 Kendrick Rd.
Robertsdale, AL 36567
MCA #3233
(205) 947-4180
6-8:30 p.m. CST

Robert W. Trotter, Jr.
7074 Majors Road
Cumming, GA 30130
MCA #23405
(404) 889-5769

Judging Tests

MCA members desiring to receive a judging test should address their requests to the person named below for specific model years:

1964 1/2-65

Bob Deale
29 Brookcrest Drive
Marietta, GA 30068

1966

Carl Henderson
1633 E. Thompson
Sapulpa, OK 74066

1968

Dave Zimmerman
6 Tainter Street
Box 213
Peapack, NJ 07977

1969-70 Bosses

Bob Perkins
N. 3183 Highway 26
Juneau, WI 53039

1971-73

Tom Podemski
1526 W. Calvert Street
South Bend, IN 56613

Shelby

Bruce Weiss
219 Cherry Drive
Melbourne Beach, FL
32951

1974-78

Tom Podemski
1526 W. Calvert Street
South Bend, IN 56613

1979-1991

Randy Church
Box 864
Baldwin, GA 30511

Special Note

MCA Gold Card Judges who did not respond to repeated requests published in *The Mustang Times* between September, 1991 and January, 1992 by providing their telephone numbers have been deleted from this listing. MCA members attending the September, 1991 National Judges Meeting voted to require that all Gold Card Judges provide their telephone numbers for this quarterly listing or face suspension of their certification. Certified Gold Card Judges who are not listed here may have their names restored to this quarterly listing by providing their name, current address, area code and telephone number, and Gold Card number to MCA National Headquarters, P.O. Box 447, Lithonia, GA 30058. MCA must receive that information prior to April 1, 1992 to insure restoration of your name by the May quarterly listing.

Corrections

Please address any corrections to any information included in this listing to: Gold Card Judges List, *The Mustang Times*, P.O. Box 447, Lithonia, GA 30058.



MCA Head Judge

Ricky Simmons
P.O. Box 387
Demorest, GA 30535

Reproduced 65-68 Anti-Vibration Compressor Braces
65/66 MCA #90-018 • 67/68 MCA #90-019



TONY & NATALIE RINALDI

P.O. Box 2178, Palos Verdes Peninsula, CA 90274 (213) 377-5889

Outside Belt Weatherstrip Separates From Belt Molding

—1974 Mustang II, All

During cold weather, the door outside belt weatherstrip may freeze to the glass and separate from the outside belt molding when the door glass is lowered.

A detached door outside belt weatherstrip can be adequately staked to the molding by performing the following repair procedure:

1. Remove the door trim panel and water shield.
2. Retrieve the door outside belt weatherstrip from inside the door and remove all existing weatherstrip-to-molding retainer clips. Do not remove the belt molding.
3. Remove the attaching screws to the upper ends of the door front and rear weatherstrip and allow the ends to hang free of the door.

Remove the window lower stop, disengage the window assembly from the regulator and lower the window to the bottom of the door.

5. Position and align the top edge of the belt weatherstrip to the offset in the molding (1.4" from the top of the molding) with the rear edges of the weatherstrip and molding flush, and hold in place. Using a No. 29 drill (.136 diameter) drill an attaching screw hole at the rear-most location through the weatherstrip molding and door sheet metal. Secure the weatherstrip to the door using a No. 8-18 X 3/8" tapping screw (Part No. 379560-S101). See Fig. 1.

6. Brush all metal chips off the weatherstrip lower lip. Reinstall the window assembly, lower stop, door weatherstrip front and rear upper ends, water shield and door trim panel.

Tachometer Adjustments

—1979 Mustang

Vehicles equipped with a tachometer have a mode selector feature. The mode switch has three positions — 4, 6, and 8 — to correspond with the number of engine cylinders. If a tachometer reading is too high or too low the following procedure is recommended to synchronize engine cylinders with the mode switch:

1. Remove trim cover from the instrument cluster.
2. Insert a screwdriver into the selector switch shaft slot.
3. Rotate the switch shaft to align the slot with the 4, 6, or 8 mark on the instrument cluster lens corresponding to the number of engine cylinders.
4. Verify tachometer readings using a service tachometer, and replace trim cover.

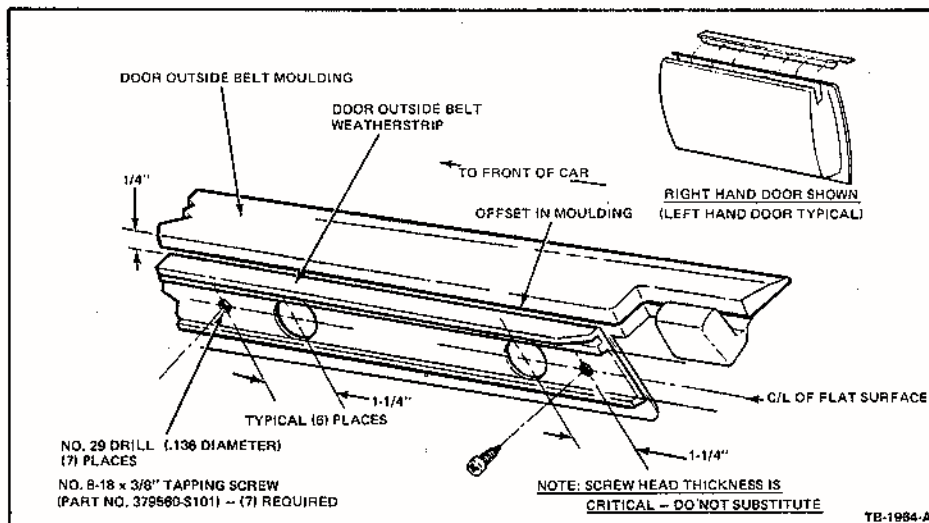

Fig. 1 — Article 701

Shift Lever Buzzing

—1974 Mustang II/w 4-Speed Manual Transmission

A buzzing noise may occur on some 1974 Mustang II vehicles equipped with a four-speed manual transmission (Model RAD). The buzz may be evident in any shift lever position.

The cause of the noise may be an interference condition in the gear shift lever; therefore, before investigating the transmission for the noise, the following procedure should be followed:

1. Verify the condition.
2. Inspect the shift boot rim ring, on some models, for grounding to the shift lever.
3. Inspect the console bezel, if so equipped, for grounding or interference with the shift lever.
4. Inspect the gear shift lever assembly for looseness in the extension housing. Tighten as necessary.
5. If all of the above items are okay, remove the gear shift lever as described in the 1974 Car Shop Manual, Volume I, Second Printing, Section 16-28-01.
6. Inspect the shifter shaft in the extension housing for a missing or broken nylon transmission gear shift damper bushing. Replace if necessary.
7. Check for interference in the shift lever vibration damper using an ohmmeter as a continuity checker (Fig. 6). Attach one lead to the shift lever shaft above the chrome plated bell on the lever. Attach the second lead to the forked end of the shift lever shaft below the transmission attaching plate and apply a 20 pound axial load to the shift lever. If continuity exists, interference is present and the gear shift lever must be replaced.

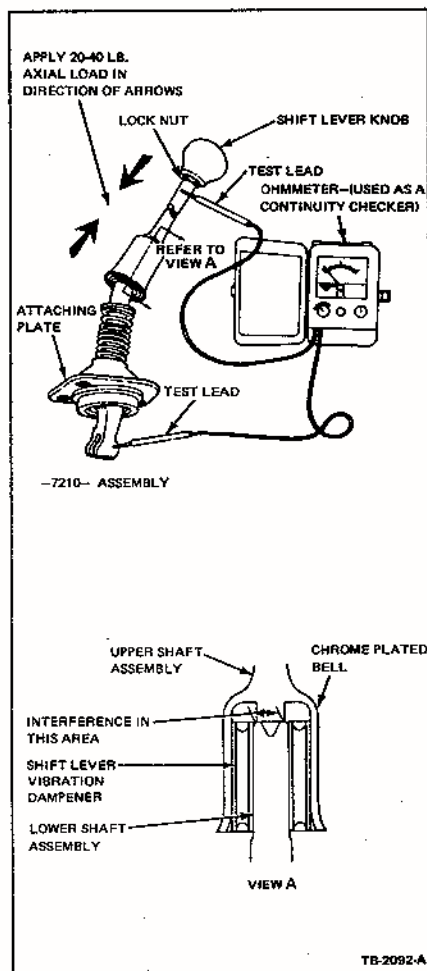

Fig. 6 — Article 820

8. If continuity does not exist, reinstall the gear shift lever and refer to the Car Diagnosis Manual, Manual Transmission and Clutch Section for further investigation.

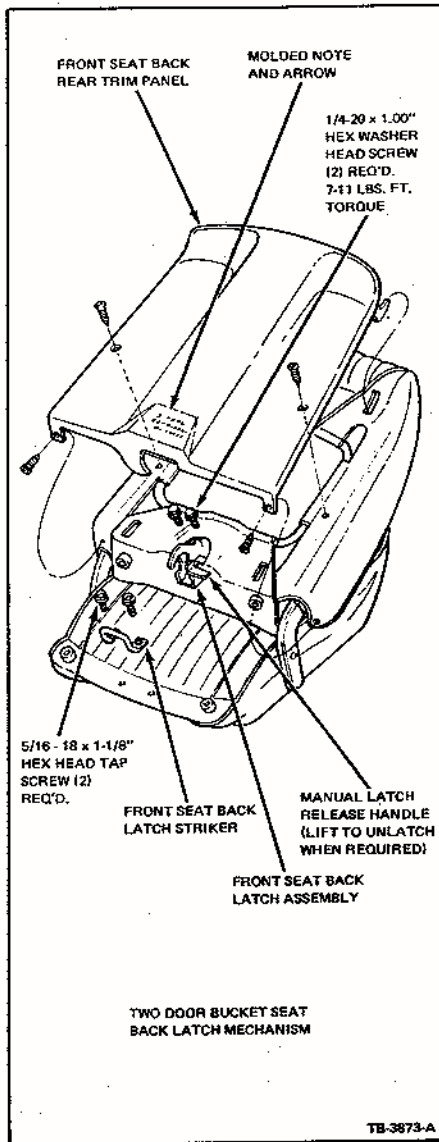

Figure 1 — Article No. 1860

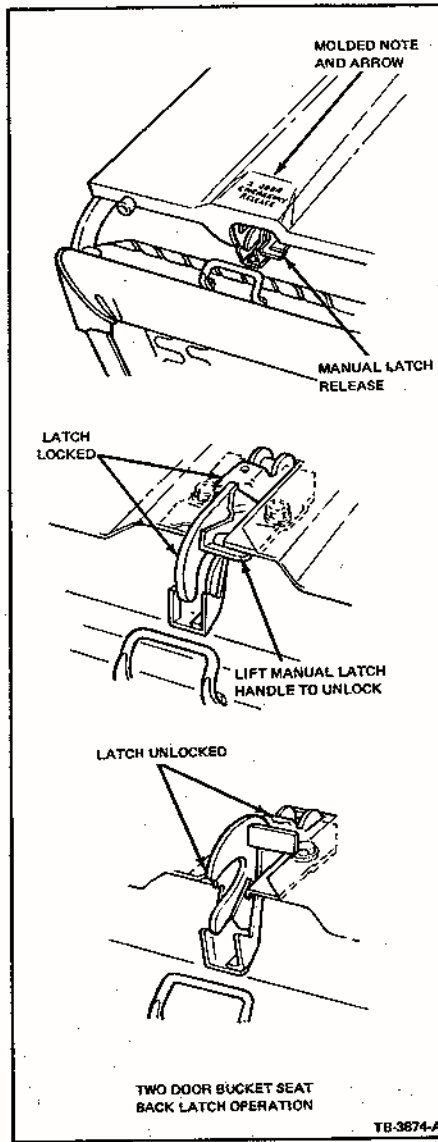

Figure 2 — Article No. 1860

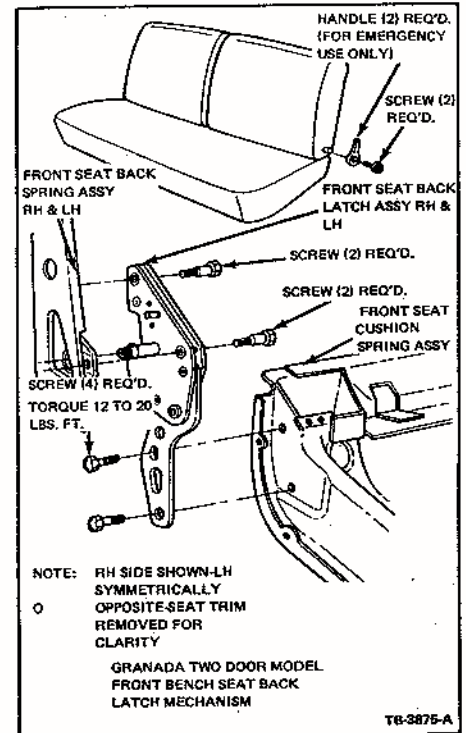

Figure 3 — Article No. 1860

Spline Damage Can Cause Gear Failures

—1974 Mustang II w/RAD Four-Speed Manual Transmission

The condition of “no drive in first, second and reverse gears (with third and fourth gears okay)” may be the result of spline damage on the 1-2 synchronizer hub allowing the hub to rotate freely on the output shaft. To correct, perform the following:

1. Make certain that transmission shift linkage is installed correctly and that the transmission shifts into all gears.
2. Remove the transmission from the vehicle following the procedure as outlined in the 1974 Car Shop Manual, Volume 1.
3. Remove the transmission top cover and inspect the shift mechanism to assure

that it functions properly.

4. If the transmission shift mechanism is functioning properly, the condition is caused by the failure of the 1-2 synchronizer hub-to-output shaft press fit. Disassemble the transmission and install a new output shaft and gear assembly (Part No. D4ZZ-7061-A).

5. Visually inspect other transmission components for damage and replace all damaged parts.

6. Reassemble the transmission and install in the vehicle. Fill transmission to correct level with specified lubricant.

Information for *The Troubleshooter* is taken from *Technical Service Bulletins* issued by Ford Motor Company.

Inertia Seat Latch Differences Noted

—1977 Mustangs

Beginning May 23, 1977, an inertia seat back latch system was installed on a few 1977 Mustangs with bucket seats. With the inertia seat back latch system it is not necessary to actuate the latch handle when folding the front seat back forward for rear seat passenger entry/exit. The latch remains unlocked with normal usage but automatically locks on rapid deceleration.

The bucket seat back latch is unique. The latch assembly installed in the seat back has an opening to facilitate the latch engaging the seat cushion striker. The bucket seat has no visible release handle, but the latch assembly is equipped with a hidden lever-type handle to manually unlock the seat back if required after it has been triggered.

If a component of the front seat back inertia latch assembly becomes non-functional or damaged in service, the entire assembly must be replaced. Under no circumstances are the latch assembly components to be disassembled for repair or replaced as individual components.

Infant seats that attach only to the right front seat back rest **should not** be used on seats equipped with the inertia front seat back latch.

German Moleiro Valencia, Venezuela
 J. Pierre Bedard Quebec, Canada
 Ron Fields Shrewsbury, MA
 Daniel Jacobs Orrington, ME
 Bruce Goodrich Elizabeth, NJ
 Mark Signorelli Maywood, NJ
 George Heaton Cardiff, NJ
 Craig Jones Somerville, NJ
 John Ruffino Mahopack, NY
 Christopher Ruffino Yorktown Hts, NY
 Philip Eygivor Wolcott, NY
 Daniel Medice Cochran, PA
 J. Franklin Carbaugh Chambersburg, PA
 Wayne Hall Jersey Shore, PA
 LeRoy Vanselous Jr. Erwinna, PA
 Sebastian Calvano Drexel Hill, PA
 Gary Overstreet Bear, DE
 G. & M. Valstro Newark, DE
 Joe Curtis Reisterstown, MD
 W.E. Livingston Chesapeake, VA
 Dave Goff Concord, NC
 Laura Hull Charleston, SC
 Tony Pope Summerville, SC
 Willie Osbourne Florence, SC
 Douglas Lumsford Anderson, SC
 James Williams Walhalla, SC
 Michael Page Winder, GA
 R.S. Towers Jr. Jacksonville, FL
 Cliff Cook Kingsport, TN
 Jack Marsh Memphis, TN
 David Segrest, MD Jackson, MS
 Wayne/Joyce McCue Crestwood, KY
 Carlos Smith Lagrange, KY
 Dennis Cart Pewee Valley, KY
 Michael Bryant Pewee Valley, KY
 Edward Johnson Smithfield, KY
 Edward Skeen Turners Station, KY
 Dale Owens Lou, KY
 Kevin Broderick Louisville, KY
 John Howard Frankfort, KY
 Fred Carby Louisville, KY
 Joe Greene Worthington, OH
 Craig Hester Grand Rapids, OH
 John Schmuckl Rocky River, OH
 George Finelli Girard, OH
 Kerry Wiland Warren, OH
 Bradley Wilkison Ashland, OH
 Sandy Scheel Clawson, MI
 Jack Wertz Livonia, MI
 Thomas Stirling Northville, MI
 Leo Rieken Henderson, IA
 Harold Mayer Kenosha, WI
 Werner Heze Blue Springs, MO
 Daniel Richardson Springfield, MO
 Relie LeBlanc III Erath, LA
 Roger Grant Tulsa, OK
 Joyce Houlette Houston, TX
 Paul Hurst Clute, TX
 Mr./Mrs. Larry Kerr Syracuse, UT
 Verne Welch Gardnerville, NV
 Kazuko Morihiro Los Angeles, CA
 Larry Helscher La Crescenta, CA
 Richard Saute Pacoima, CA
 David Schleeter Pacifica, CA
 Ryan McClure Portland, OR
 Brian Christy Auburn, MA
 Ed Cangialosi Hastings-on-Hudson, NY
 Joseph Quarranto Holley, NY
 John Dunlap Jr. Erin, NY
 Robert Weir York, PA

Our Newest Member...

Jerry Tisdale of Scarborough, Ontario Canada is the newest member of the Mustang Club of America, having been assigned Membership No. 25,654. We welcome Jerry and the many other new members listed here to MCA.

Lee Benson Muncy, PA
 Robert Brian Fairless Hills, PA
 Lawrence/Wendy Katz Rockville, MD
 Patrick Bocato Virginia Beach, VA
 Jerry Gibson Mullins, SC
 Leroy Gardner Stone Mountain, GA
 C.M. Gazaway Rex, GA
 Richard Hanner Gainesville, GA
 Christopher Paige Palatka, FL
 Gary Wieland Port Charlotte, FL
 M. & G. Kochel Ft. Knox, KY
 Tom Mystrom Grand Forks, ND
 Ken Schumacher Henry, IL
 Jerry Wood Bridgeton, MO
 Robert Simmons Baton Rouge, LA
 David Stockfinger Baton Rouge, LA
 W.A. Tate Caddo Mills, TX
 John T. Coffey Jr. Peoria, AZ
 Fred Sargott Rosthern, Canada
 John Crandall Monchton, Canada
 Mark Nerfurth Carteret, NJ
 Arthur Mezzo Murray Hill, NJ
 J. Michael Coyne II Toms River, NJ
 Craig Chepeleff Potsdam, NY
 Joela Schmid Rochester, NY
 James Alexander Hatfield, PA
 Wilson Eshbach Reading, PA
 Paula Kane Falls Church, VA
 M. Binswanger Richmond, VA
 Cindy Wersching Shelby, NC

William Craig De Funiak Springs, FL
 Ed Turner Fort Payne, AL
 Don Hersko Columbus, OH
 Thaddeus Klejka Niles, PH
 Rick Dynes Ansonia, OH
 J. Michael Caylor Greenwood, IN
 Georgia Johanning Poynette, WI
 Dan Adams St. Louis, MO
 Richard Mason Independence, MO
 John Henderson Brock NC
 Anthony Griffith Houston, TX
 Charles Boehler Albuquerque, NM
 Frank Gray Albuquerque, NM
 Capt. I. Chancellor Sultanate of Oman
 Jerry Tisdale Ontario, Canada
 Crews Classic Cars Dedham, MA
 Jack Emanuel Brookfield, CT
 Kenyon Brede Danbury, CT
 Carol T. Hafer Port Washington, NY
 Gary Green Hornell, NY
 Vic Freeman Collegeville, PA
 Ken Dunlap New Martinsville, WV
 David Lee Schaich Marietta, GA
 Matthew Jarvis Snellville, GA
 Thomas Gamble Warner Robins, GA
 John Czyski Miami, FL
 Phillip Petry Valrico, FL
 Scott Guinn Henagar, AL
 Jay Riggs Lancaster, OH
 Tom Sechich Painesville, OH
 David Kansa Akron, OH
 Alan Hoffman Jasper, IN
 Mike Engel Davenport, IA
 Jack Erdmann Watertown, WI
 Kent Sharpe West Bend, WI
 James Evans Crystal Lake, IL
 Mr./Mrs. C.J. McManus Palatin, IL
 Doug Franklin Eufaula, OK
 Jack Durrett Bullard, TX
 David Miller Pearce, AZ
 B.J. Aday Portales, NM
 Stan Apperson Portland, OR

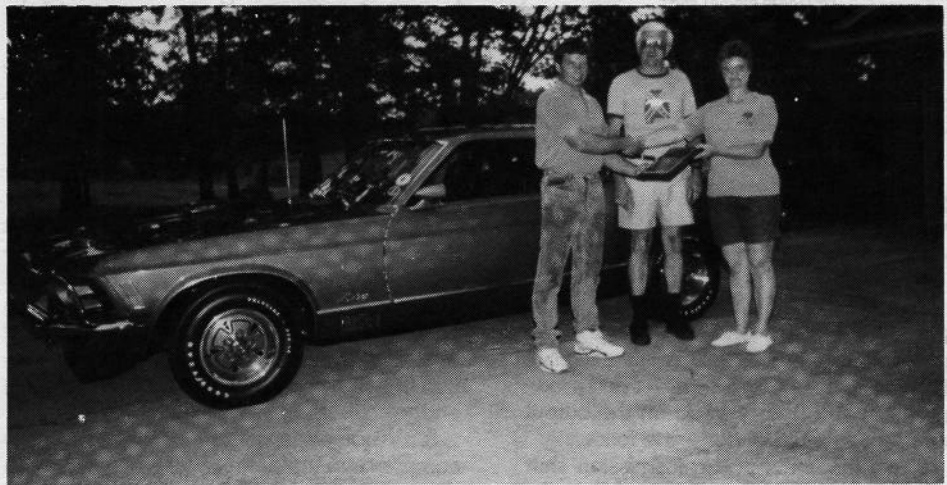

Stones Retire '70 Mach I

Malcolm and Nita Stone of Brandon, MS (MCA Membership #3600) recently retired their 1970 Mach I SCJ Mustang. The car has won numerous MCA National and Grand National events from the early 1980s to the present. Former MCA National Head Judge Bob Perkins made the presentation of the retirement plaque to the Stones.

Dr. Hufnagel Gunter of Omaha, NE acquired his 1970 Mustang convertible in June of last year and uses it as a daily driver during the summer months. The Candy Apple Red Pony has a black deluxe interior and a 351C-2V. Though Dr. Gunter says his Mustang is an "older restoration, it's still in good condition." The odometer now shows 167,000 miles. Dr. Gunter's MCA Membership Number is 25460.



Andy Weiser of Smyrna, GA purchased his '85 Mustang GT hatchback last September and he says he is now in the process of rebuilding and restoring it. He has modified the Pony by lowering it five inches all around and "giving it more horsepower." The red Pony has gray and black deluxe interior and is Andy's "main transportation." His MCA Membership Number is 25,282.

David Jones of Monroe, LA is the owner of this 1966 Mustang hardtop, which he uses for weekend pleasure driving. A member of the Quachita Valley Mustangs, David purchased his Pony in March, 1991. The '66 is Wimbledon White with black vinyl top, has Cruise-A-Matic, air, and a luggage rack. The 200 CID six has 107,000 miles on it. David's MCA Membership Number is 24342.



CALENDAR OF EVENTS

February 9 **Nashville, TN**
The Fourth Annual Nashville Automotive Swap Meet will be held at the Tennessee State Fairgrounds in Nashville. The event is sponsored by the Stones River Region of the Antique Automotive Club of America. There will be a \$3 donation at the door. For more information contact Jesse Harvey at (615) 896-3404 after 6 p.m. or Butch Roth at (615) 893-8004 days.

February 11 **Atlanta, GA**
The February meeting of the Board of Directors of the Mustang Club of America will be held at the Marriott Courtyard Hotel at I-75 and Windy Hill Road north of Atlanta. The meeting begins at 7:30 p.m. and is open to all current MCA members.

March 1 **Atlanta, GA**
Applications for the 1993 Mustang Club of America Grand National must be received by the MCA Board of Directors. For application forms or additional information contact Jim Watson, National Show Coordinator, C/O MCA, P.O. Box 447, Lithonia, GA. 30058.

March 6-7 **Jackson, MS**
The Mid-Mississippi Mustang Club will present "The Biggest Little Indoor Car Show of the South" in the A&I Buildings on the Mississippi State Fairgrounds. Modified MCA rules apply. Discounts are available for early registration. Indoor space is limited to 125 cars and vendors. For registration and lodging information write: The Mid-Mississippi Mustang Club, P.O. Box 2063, Jackson, MS 39225-2063 or call Susanne Dalton at (801) 857-2923 or Kim Barnes at (601) 546-2930.

March 10 **Atlanta, GA**
The March meeting of the Board of Directors of the Mustang Club of America will be held at the Marriott Courtyard Hotel off Windy Hill Road at I-75 north of Atlanta. The meeting begins at 7:30 p.m. and is open to all current MCA members.

March 22 **Irvine, CA**
The Saddleback Mustang Association will present its fifth annual car show from 10 a.m. to 3 p.m. at Western Digital Corporation, 8105 Irvine Center Drive. Pre-registration is \$12 per car and must be received by Feb. 28. Show day registration is \$15. Participant cars will be permitted to enter the show area between 6:30-9 a.m. Shelby's, modifieds, Saleens, special interest and other Ford vehicles are welcome. There will be 19 classes and 56 trophies awarded. No outside vendors, parts cars or cars for sale will be permitted. All cars entered must remain in place until the awards presentation. For additional information call Jim Howell at (714) 249-1291 or David Renwick at (714) 551-2479.

March 27-28 **Pensacola, FL**
The 13th annual Gulf Coast Regional Mustang Show will be held at University Mall, I-10 at Exit 5. Early tech inspection will begin at 8 a.m. March 27 and continue until 5 p.m. A fish fry and hospitality party will be held at Hampton Inn from 6-11 p.m. Friday. Registration, tech inspection and parking will resume at 7 a.m. Saturday and judging will be held from noon to 5 p.m. An awards presentation will be held at 7 p.m. Saturday. Vendors are welcome, and must pre-register by March 15. All show vehicles must remain in place until 5 p.m. March 28. A 1968 Mustang convertible will be given away Saturday. Proceeds from the project car will benefit Ronald McDonald House, Transportation Fund for the Shrine Hospital for Burned Children, and Sacred Heart Children's Hospital. A registration form for the Gulf Coast Regional Mustang Show is included in this issue of *The Mustang Times*.

April 1 **Atlanta, GA**
Applications for 1993 Mustang Club of America sanctioned National Shows must be received by the Board of Directors. For application forms or additional information contact Jim Watson, National Show Coordinator, C/O MCA, P.O. Box 447, Lithonia, GA 30058.

April 11 **Braselton, GA**
The Northeast Georgia Mustang Club's Chateau Elan Show and Shine

will be held at the winery off I-85 north of Atlanta. For information contact Kitty Wilmot at (404) 992-1729.

April 14 **Atlanta, GA**
The April meeting of the Board of Directors of the Mustang Club of America will be held at the Marriott Courtyard Hotel off Windy Hill Road at I-75 north of Atlanta. The meeting begins at 7:30 p.m. and is open to all current MCA members.

April 17 **Detroit, MI**
The 28th anniversary of the introduction of the Ford Mustang, which made its debut April 17, 1964.

April 25 **O'Fallon, IL**
The Shiloh Valley Mustang Association will host its second annual MCA Regional Mustang/Ford Show and Swap Meet at the Wal-Mart parking lot, one-half mile west of I-84 on Highway 50. A total of 42 classes will be offered and MCA rules will apply to the 20 judged Mustang classes. The remaining 22 classes will be judged by participant vote. Three trophies will be awarded per class. All Fords and Ford-powered vehicles are welcome. Vendors are also invited. A Pony Corral will be available. Pre-registration closes April 15. Registration and tech inspection will be held from 7 a.m. to noon the day of the show. Judging begins at noon. Awards will be presented at 4:30 p.m. For information contact Henry at (618) 537-4225 or Bob at (618) 277-6838.

May 1-3 **Oxnard, CA**
The Mustang Owners Club of California will present its 13th annual West Coast Meet at the Casa Sirena Hotel, Channel Islands Harbor. Admission to the show is free and cars will be on display Saturday from 10 a.m. to 4 p.m. Concours and peoples' choice classes will be available. There will be approximately 100 cars on display. Entry fee is \$27 per car. Pre-registration is required and must be received no later than April 22. No car registration show day. For show or registration information contact Joe at (805) 529-3245 or Wayne at (818) 343-2091.

May 3 **Rockville, MD**
The annual National Capital Region Mustang Club Spring Concours Show will be held at Montgomery College's Rockville campus. 1965-73 Mustangs, Shelys, and special interest Fords are welcomed. The show will include vendors and a car corral. Admission is free. For information contact NCRMC, 814 Woodley Drive, Rockville, MD 20850 or phone (301) 762-1451 or (703) 528-8254.

May 12 **Atlanta, GA**
The May meeting of the Board of Directors of the Mustang Club of America will be held at the Marriott Courtyard Hotel off Windy Hill Road at I-75 north of Atlanta. The meeting begins at 7:30 p.m. and is open to all current MCA members.

May 14-16 **Las Vegas, NV**
The third "Great American Classics Mustang Show" will be held, sponsored by the Mustang Club of Las Vegas. In addition to the car show, there will be an open track event and a "Las Vegas-style" weekend. For additional information call or write Don & Sharon Hafen, 6648 Costa Brava, Las Vegas, NV 89102, (702) 365-1099.

May 16 **St. Petersburg, FL**
The fifth annual Mustangs and Ford Muscle on the Pier will be held. The event is sponsored by the Suncoast Mustang Club of Florida. More than 22 classes will be featured. Florida Council rules will apply with trophies and 200 dash plaques. A model car show will also be held. Pre-registration is \$14. Show day registration is \$17. Spectator admission is free. For information contact Bob Wilhelm at (813) 522-0858 or John Moody at (813) 786-3048.

May 23-24 **Kennawick, WA**
The 12th annual Spring Show-N-Shine and Fun Run, sponsored by the Pacific Northwest Mustang Club will be held at Cavanaugh's, 1101 Columbia Center Boulevard. The Fun Run and a hospitality party will be held on the 23rd and the show on the 24th. Participant voting and peoples' choice voting will be included with 60-plus awards to be

presented. An awards banquet will follow the show. Guest speaker for the banquet will be Drew Alcazar of Concours Restoration. The show is open to all Mustangs, Bosses, Shelbys, and Ford-powered cars. Non-Fords and vendors are welcome. Contact Harold L. Odahlen at (509) 377-4171 days or (509) 783-6309 evenings.

June 9 **Atlanta, GA**
The June meeting of the Board of Directors of the Mustang Club of America will be held at the Marriott Courtyard Hotel off Windy Hill Road at I-75 north of Atlanta. The meeting begins at 7:30 p.m. and is open to all current MCA members.

June 12-14 **Belle Fourche, SD**
The Center of the Nation All-Car Rally will be held. Events will include a Friday Cruise Night and a Saturday Show 'n Shine. Registration will be held from 8 a.m. until noon and judging will be from noon to 3 p.m. An awards ceremony will be held at 5 pm. Saturday followed by a picnic. A fun run and a demolition derby will be held Sunday. For additional information contact Center of the Nation All-Car Rally, P.O. Box 41, Belle Fourche, SD 57717 or phone (605) 892-2154.

June 14 **Fayetteville, OH**
The third annual Rocket Run '92 will be held with classes for all makes and models of collectible cars, including classic Mustangs. The event will include an auction and flea market. The event is sponsored by the Fayetteville PTA and the Brown County Cruisers Inc. For information contact Debbie at 3940 Anderson State Road, Fayetteville, OH 45118 or phone (513) 875-3647.

June 20 **Murfreesboro, TN**
The seventh annual All Ford Show and Swap Meet, hosted by the Performance Ford Club of America's Central Tennessee Region will be held at Central Middle School. There will be first, second and third place trophies, parts vendors, a car corral, a model car contest, games, door prizes and dash plaques to the first 200 entries. Spectator admission is free. For more information call Frances Stacey at (615) 896-5514.

June 27-28 **Indianapolis, IN**
The Mustang Club of Indianapolis will host the first MCA National Show of the 1992 season. Complete details and registration information will be forthcoming in later issues of *The Mustang Times*.

July 14 **Atlanta, GA**
The July meeting of the Board of Directors of the Mustang Club of America will be held at the Marriott Courtyard Hotel off Windy Hill Road at I-75 north of Atlanta. The meeting begins at 7:30 p.m. and is open to all current MCA members.

July 18 **Alton, IL**
The 15th annual Mustang Round-Up Car Show and Swap Meet, sponsored by the Southern Illinois Mustang Association, will be held at Roberts Ford-Chrysler-Plymouth, Alby Street and Beltline. Rain date is July 19. Registration will be held from 8 a.m. until noon judging will begin at 3 p.m. Entry fee is \$10. Swap spaces are \$15. Trophies will be awarded in all classes. For additional information call (618) 465-2482 or (618) 585-3081.

July 19 **Georgetown, OH**
The 11th annual Car Show Cruise-In '92, sponsored by the Brown County Cruisers and the American Heart Association will be held at the Brown County Fairgrounds on Route 125. More than 25 classes will be offered for all makes of cars, trucks, street rods, classics and antiques. A model car show and swap meet will also be held. For additional information contact Gary at (513) 379-1495 or John at (513) 378-6536.

August 11 **Atlanta, GA**
The August meeting of the Board of Directors of the Mustang Club of America will be held at the Marriott Courtyard Hotel off Windy Hill Road at I-75 north of Atlanta. The meeting begins at 7:30 p.m. and is open to all current MCA members.

September 4-6 **Marietta, GA**
The 1992 MCA Grand National will be held at the Marriott Hotel off I-75 north of Atlanta. The event will be sponsored by the Georgia Regional Mustang Club, the Northeast Georgia Mustang Club and the Cherokee Mustang Club. Additional information will be forthcoming in upcoming issues of *The Mustang Times*.

September 8 **Atlanta, GA**
The September meeting of the Board of Directors of the Mustang Club of America will be held at the Marriott Courtyard Hotel off Windy Hill Road at I-75 north of Atlanta. The meeting begins at 7:30 p.m. and is open to all current MCA members.

October 9-11 **Lynchburg, VA**
An MCA National Mustang Show will be held, sponsored by the Lynchburg, VA Area Mustang Club, an MCA regional group. Additional details will be provided in forthcoming issues of *The Mustang Times*.

October 13 **Atlanta, GA**
The October meeting of the Board of Directors of the Mustang Club of America will be held at the Marriott Courtyard Hotel off Windy Hill Road at I-75 north of Atlanta. The meeting begins at 7:30 p.m. and is open to all current MCA members.

The Mustang Times welcomes items for its monthly calendar of events. To have your regional group or club's activity listed, send all pertinent information to "Calendar of Events," *The Mustang Times*, P.O. Box 447, Lithonia, GA 30058. Be sure to include the name and telephone number (with area code) of a contact for readers who desire more information. Please submit items at least 60 days in advance of the event to assure publication on a timely basis.

64½ MUSTANG 66 AIR-CONDITIONING

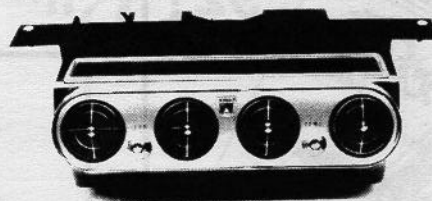

One Part or Complete System
TRY US!

ALL FORD

Under-dash units

and clutches remanufactured!!

Parts available through 1973

Dealer Inquiries Welcome

Call or Write for FREE CATALOG

CLASSIC AUTO AIR MFG. CO.

Unit MT, 2020 W. Kennedy Blvd.

Tampa, FL 33606

813-844-3681 or 813-251-2356

Cars For Sale

1970 Boss 302, Lime Gold, emission equipment, rev limiter, console, AM/FM, shaker, louvers, spoilers, Magnums, fold-down seat, space saver, tilt wheel. Not perfect, but very good condition. Extra parts included. Can't give it TLC it needs so decided to sell. Price: \$15,000 OBO. Call (507) 524-4798 or write P.O. Box 75, Mapleton, MN 56065. MCA Member #20291.

1966 "K" GT coupe, Pony interior, four-speed, completely restored, all numbers match. SS wheels. If you have been looking for that beautiful "K" GT coupe, this is it. No disappointments. Price: \$15,500. Call (510) 799-2502. MCA Member #19031.

1983 GT convertible, 65,000 miles, 5.0 five-speed, tilt wheel, power windows, cruise control, new white top, red with red interior. One of 993 made. Call Randy Church at (404) 778-3413 after 7 p.m. EST. MCA Member #17916.

1966 and 1967 convertibles, 1966 is white with new blue top with blue Pony interior, 200 CC, three-speed. 1967 is light green with Ivory Gold

interior, 289, three-speed, 89,000 actual miles, PS, AT. Price: \$9,000 for either. Call (601) 323-8203. MCA Member #24368.

1987 Mustang Saleen, No. 190. White with blue Saleen graphics. All original with only 3,700 miles. Will sell for \$19,000 bank payoff. Call (904) 862-1240 after 7 p.m. MCA Member #1292.

1973 Mustang convertible, Gold-Glo exterior, 351 Cleveland, AT, two-barrel, AC, PT, PS, PB, PW all four, Rim Blow Deluxe tilt steering wheel, Ginger interior, knitted vinyl seats, console, AM Radio with 8-track, interval windshield wipers, tinted glass. Price: \$6,000. Call (513) 821-4928. Farrel Buis, 399 Marycrest Drive, Cincinnati, OH 45237. MCA Member #10287.

Pair of 1965 GT "K" HiPos, one white fastback and one turquoise convertible. Both have factory AM/FM, four-speed, SS wheels. Convertible has Pony interior. Both cars national show winners. Will sell separately. Serious inquiries only, please. Contact Steve at (305) 561-1243, Ft. Lauderdale, FL. MCA Member #12795.

1964 1/2 convertible, very early production, 260 V-8, AT, PS, power top. Original black paint with red stripe. Red interior with console. New tires, brakes, shocks, and complete exhaust system. Restoration started with genuine Ford parts. Price: \$5,000. Call or write for details. Frank Zuest, 1817 Pulaski Drive, Blue Bell, PA 19422, (215) 272-3821. MCA Member #23649.

1968 Shelby GT 350, 8T02J 192428-0211, totally disassembled. Call for details. Price:

\$12,995. Jimmy Austin, (214) 286-2100. MCA Member #16683.

1973 convertible, red with white top, Cleveland engine, new paint, excellent condition. Sacrifice. Call Jack Cashin at (404) 664-1533. MCA Member #25051.

1967 Mercury Cougar, 289-2V, four-speed, PS, AC. In family since 1973. Driven daily. Numerous recent mechanical improvements. Needs cosmetic restoration. Excellent and rare restoration project. Price: \$1,500 OBO. Call Tom at (615) 255-4850 days or (615) 399-1416 nights. MCA Member #959.

1973 Mustang sportroof 302, 2V, three-speed, 78,000 miles. Burgundy with black and Burgundy interior. 90 percent restored. Not driven in winter. 8 1/2 chain link steering wheel. Have photos. Won trophies last two years. Price: \$2,800. Call Don at (216) 848-1422. MCA Member #24207.

1970 Boss 302, restored, show winner, white and black, spoilers, slats, shaker hood, drag pack, deluxe interior, console, AM/FM, clock, gauges, Magnum 500s, new clutch, tires and front suspension. VIN 0F02G151869. Best offer or trade. Call (404) 448-8081. MCA Member #24745.

1970 Mach 1, 351-2V, AT (FMX), AC, PS, PB, original stereo, sport seat, bright blue metallic, fully restored. Price: \$12,500 OBO. Call Larry at (215) 745-6638. MCA Member #24541.

1968 Mustang convertible, 289, AT, PS, PB, factory AC, new white power top and tires, interior and exterior completely restored. Interior Parchment, exterior Candy Apple Red with clear coat finish. Price: \$10,900. Call (813) 426-6570. MCA Member #25247.



ALL NEW FOR '92!

GLAZIER'S MUSTANG BARN

Mail Order Parts Catalog



PARTS

CATALOG!

GLAZIER'S MUSTANG BARN

531 Wambold Road
Souderton, PA USA 18964
Phone: 215-723-9674
Fax: 215-723-6277
US AND CANADA
CALL TOLL FREE
1-800-523-6708

Attention MCA Members

Mustang Times

Classified Ads Are Free To All Members

To take advantage of this free service submit your classified advertisement by the first of the month for the next month's publication. Ads are limited to 50 words per member per month. Check this month's classified section for categories.

Mail Your Ad Today

Classified Ads

The Mustang Times

P.O. Box 447

Lithonia, GA 30059

NEW! '64 1/2- '91 THERMOSTAT HOUSING FOR MUSTANGS AND FORDS

260 - 289 - 302 - 351 w - w/o smog

CONCOURS CORRECT! THE SEARCH IS OVER! **only \$19.95**



(Dealer Inquiries Invited.)
SACRAMENTO MUSTANG
5710 Auburn Auburn Blvd. #23
Sacramento, CA 95841
(916) 334-0190 (800) 442-8333

1965 Mustang fastback, yellow with black interior, dependable six-cylinder, AT, PS, solid body, everything is factory original. Price: \$6,200. Call Pete at (407) 859-0800. MCA Member #25047.

1965 Mustang convertible, 289-2V, AT, PS, PB, PT, Pony interior, console, Maroon exterior, spinner hubcaps, excellent condition. Best offer over \$12,500. Also, 1965 Mustang hardtop, 289-4V, four-speed, white with black interior, spinners, very good condition. Original owner. Price: \$10,000. Call (203) 265-2443. MCA Member #22509.

1969 Mach 1, 351, AT, PS, PB, Jade and white. Needs floors and smokes, but nice original car. Price: \$3,650. Also, 1969 convertible, S code 390, rare deluxe interior, PS, PB, rusty and missing drivetrain. Call (314) 832-2758 days or leave message. MCA Member #22490.

1965 Mustang CP, 289, AT, PS, PB, factory AC, bench seat, 66,538 original miles. Red with red interior. Good interior and mechanical condition. Strong floor and unibody. Garage kept. Needs minor rust repair and vinyl top. Price: \$4,000. Call Mike at (215) 365-0228. MCA Member #17506.

1966 Mustang GT fastback, Nightmist blue metallic, Parchment and blue interior. Four-speed, AC, Magnum 500s, woodgrain steering wheel, disc brakes, fold-down rear seat, completely restored in and out. Price: \$13,500. Call (404) 351-9698. MCA Member #24881.

Parts For Sale

Restored 1969-70 deluxe steering wheels, \$225. With center pad, \$275. Restored 1968 deluxe steering wheels, \$250. With center pad, \$350. Your deluxe steering wheel (1968-73) restored, \$100 and up, depending on condition. Standard wheels also restored, \$50 and up. Contact Sunset Mustang, 7846 Chasewoods Drive, Jonesboro, GA 30234 or phone (404) 447-0072. MCA Member #16313.

1964 1/2-73 switches, all are NOS in box: 1964 1/2-66 turn signal, \$28; 1967-69 tilt/signal, \$35; 1967-69 signal, \$30; 1969-70 headlight, \$10; 1965-66 four-speed backup, \$20; 1967-68 four-speed backup, \$25. Prices limited to on-hand stock. Normal shipping applies. Metro Mustang, (404) 767-3378. MCA Member #24252.

C8ZZ-9030-C NOS pop-open gas cap, \$55. C7ZZ-9030-A repro standard gas cap, new, \$20. Call Mike Kavalukas at (412) 276-2156. MCA Member #22109.

1967 Mustang front fenders, chemically stripped and primed, left and right, \$150 each. 1967 rear exterior vent panels, \$50 pair. 1967 NOS right coupe quarter C7ZZ-6527840-A, \$300. Mustang custom rotisserie, \$600. Call for details, (205) 883-2948 or write Howell

Hooper, 8817 Bridlewood Drive, Huntsville, AL 35802. MCA Member #20994.

Pot metal hood scoop inserts for 1971-73 Mach 1 style hoods, \$85 with NOS air scoop grill plates. \$75 without plates. NOS air scoop grill plates D1ZZ-16A625-A or D1ZZ-16A624-A, \$12 each or \$20 for both. Richard Waddle, (501) 631-2731. MCA Member #21638.

NOS Mustang parts. Over 1000 part numbers. Also, rebuilt original 1965-71 vintage starter relays, radiator caps, voltage regulators, front suspension. Boss and Super CJ vacuum advance unit rebuilding. Send \$1 for "Mustang List" to Max Kotlowski, 210 E. College, Broken Arrow, OK 74012 or call (918) 251-0362. MCA Member #23986.

Parts Wanted

1968 fastback deluxe interior passenger side armrest. Good condition only. No cracks or cuts. Any color, but aqua preferred. Call (908) 270-5832. Evenings best. MCA Member #23388.

1968 California Special grill for Marchal

foglights. Also, one side scoop grill insert. Call (801) 776-4230. Larry Kerr. MCA Member #25523.

1965 disc brake set-up. Preferably complete and must be working or rebuildable. Call (713) 480-2206. MCA Member #25583.

1971-73 Mach 1 racing-type gas gap in very good condition. 1971-73 optional bumper protection group. Also, 1975-78 radiator shroud, Mustang II '78 King Cobra front air dam and Cobra caps for lacy spoke wheels, Phil Schmidt, (612) 448-2931. MCA Member #24387.

Miscellaneous Wanted

Shelby or Mustang Monogram, Hot Wheels, Matchbox, Yatming, 1/59th, 1/43rd, 1/40th or 1/32nd scale cars in good condition to expand my collection. Send information to Brian Fenech, PSC Box 665, McClellan AFB, CA 95652 or call (916) 643-4259, Room 51. MCA Member #25030.

Sales literature: Mustang SVO, "Intelligent Execution of Total Performance" Vol. 5 PC 020



zymöl®

"Fantasy"

Developed for American Classic Automobiles

- A Completely Natural Product
- Three "Custom" Formulas
- No Petrochemicals, Silicones or Abrasive Compounds
- 28-38% Rare "White" & "Yellow" Brazilian Carnauba

CORCO WEST, INC.

Authorized Distributor
Wholesale/Retail

1-800-533-5743
1-501-638-8873

(Training and Communication), back issues of *Ford Times* (10/83), (5/84), (6/84). Joe Greene, (614) 889-1962 or write to 1962 Starbridge Court, W. Worthington, OH 43235-1876. MCA Member #25513.

Miscellaneous

Pony portable parts washer. Air operated. Environmentally safe. Fast, efficient, hands-off cleaning of carburetors, brake cylinders, small parts. Fits inside five-gallon solvent container. Unit comes complete with lid, air motor, degreasing basket with heavy duty handle and one year guarantee. \$129 including shipping and handling. Distributors wanted. Call (314) 921-PONY. MCA Member #10045.

Model kits, banks, books, decals, etc. Send for free list. Bill Koivu, P.O. Box 7, Lithonia, GA 30588. (404) 482-9219. MCA Member #758.

1965-73 Mustang tachometer, clock, speedometer, gauge and motor repair and conversions. Also, NOS parts: mirrors, clocks, moldings, ornaments, lenses. Over 6000 items. Send \$3 for list. State model and year. Joe Russell, 11 MacGregor Drive, Mahopac, NY 10541. Phone (914) 628-4866 after 6 p.m. MCA Member #21337.

Zymol Car Care Products. Derived from 110-year-old German carriage wax formula. Each product is natural. We utilize only plant oils and their derivatives as opposed to chemicals and synthetic waxes. Protect your investment with the best car care products available. For information call Corco West, Car Care Division, at 1-800-533-5743. MCA Member #22426.

Mustang models. Made of pecan shell and select fine woods. Handcrafted. Intricately detailed, 1965 hardtop, 1965 fastback, 1970 Boss, 1968 Shelby. Only \$9.95 each plus \$3 shipping and handling. For free brochure, send large SASE to C.C. Miniatures, 4930 Park Boulevard, Suite 3, Pinellas Park, FL 34665. MCA Member #24625.

Playboy Pink Registry! All owners of the Playboy Pink cars are asked to respond, sending complete data plate info with VIN to Robert L. Finney, P.O. Box 1036, Price, UT 84501. Will reply to all responses. MCA Member #23655.

Gold Plated Keys and NOS Keys. For free catalog send large (No. 10) SASE (two stamps) to Joey Jesser, 26 West Street, Akron, OH 44303-2344 or phone (216) 376-8181. MCA Member #23296.

1992 Calendars! The official Mustang Club of America 1992 wall calendar, featuring 12 of the most outstanding Mustangs in the nation. This collector's item is a high-quality, beautifully designed tribute to the Ford Mustang. Perfect for your own collection or as a gift for

any Mustang lover. Send \$8 plus \$2 for shipping and handling (via first class mail) to: MCA 1992 Calendar, P.O. Box 447, Lithonia, GA 30058. Club discounts available for quantity purchases.

Brake booster rebuild, \$75. One-day turn around. Free UPS. Rebuild yours or exchange. Plating available. One-year warranty. Call "Booster" Dewey at (503) 238-8882. Portland, OR. MCA Member #24831.

For sale: Mustang brochures, post cards, performance catalogs, posters, 1964½-1991. Send SASE for free list to Randy Church, P.O. Box 7, Baldwin, GA 30511 or call (404) 778-3413. MCA Member #17916.

Consoles restored. Send us your broken, cracked, unusable console for quote. Correct woodgrain (laminated on metal) installed or we

have kits for sale. We also do glove box doors, heaters and AC units to show quality. Mustangs and Thangs, 2114 Bloomingdale Pike, Kingsport, TN 37660. Call (615) 288-8488. MCA Member #231.

Scale replicas for sale: 1/24th and 1/25th scale. NASCAR Fords, Mustangs, etc. All years available. Built or unbuilt to your specifications in die cast metal or plastic. Also sell complete line of models and NASCAR replicas. 134 Cottonwood Court, Stockbridge, GA 30281, (404) 907-0472. Send SASE for list. MCA Member #24252.

Mustang tach and clock repair. Clocks updated to quartz. Tachs repaired, calibrated. Complete 1965-66 Rally-Pac restoration, including dial refacing. Gary Herbert, 4 Clear Creek Court, Simpsonville, SC 29681. Call (803) 967-7719. MCA Member #17909.

Classified Advertising

Classified advertising is **free to all members** of The Mustang Club of America. To take advantage of this valuable service, submit your classified ad to **The Mustang Times**, P.O. Box 447, Lithonia, GA 30058-0447. Please include your **membership number** on your advertising copy to insure its inclusion in our next issue.

Advertisements are **limited to one insertion of no more than 50 words per month**, per member. Advertisements exceeding 50 words will be edited or refused, at the discretion of the magazine's staff. **The Mustang Times** will not be responsible for the correction of illegible advertising copy. **Please type or print plainly** to help us avoid errors. It is also essential that you include an **area code** for all telephone numbers to be listed in the classified advertising section. Ads submitted without area codes will not be published. Non-member commercial advertising is not permitted in the classified advertising section.

All correspondence relating to classified advertising must be handled by mail. We are not able to return long distance telephone calls relating to classified advertising nor are we permitted to accept classified advertising by telephone.

Advertisements to be repeated must be resubmitted each month. The deadline for classified advertising is the first of the month for the next month's edition (March 1 for the April edition, April 1 for the May edition, etc.)

Classified advertisements received after the first of the month will be held for inclusion in a later edition.

Display Advertising

Display advertising is available to vendors, restorers, businesses and other organizations interested in marketing their products and services to the Mustang Club of America's worldwide membership.

One-time insertion rates and discounted contract advertising rates are available.

Display advertising deadlines are the first of the month for the next month's issue (March 1 for the April issue, April 1 for the May issue, etc.)

All advertising must be accompanied by full payment. Advertising submitted without full payment will be returned unpublished. Contract advertisers are required to submit two month's pre-payment with their initial copy and will be billed monthly thereafter.

For advertising rate information contact Steve McMullan, 3719-A Oakwood Hills Drive, Oakwood, GA 30566, (404) 535-1566 between 9 a.m. and 7 p.m. EST Monday through Friday.



T2 RHT2000