

MUSTANG TIMES

April 1983



The Official Publication of

THE MUSTANG CLUB OF AMERICA

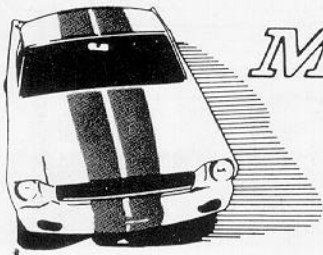

MUSTANGS unlimited inc.

21 Tolland Turnpike, Manchester, CT 06040
(203) 647-1965

MOLDED CARPET SETS - We offer you the finest molded carpet available for your restoration. 80/20 rayon/nylon loop, color-keyed toe and heel pad, original jute backing. The following colors in stock for immediate delivery: black, red, blue, maroon, light green, tobacco, dark green, turquoise, emberglo, saddle, gold, tan.

Coupe, Conv., Fastback \$100.00
Fold down section \$15.00

CONTOURED CARPET SETS - Our sewn carpet sets are of the same quality as our molded carpets and fit perfectly.

64-68 \$65.00
W/Fold Down \$87.00

MUSTANG FLOOR MATS - Original Ford Pony mats. Available in black, red, white, blue, green, tan and maroon.

Set of 4 \$45.00
Fronts, Only \$30.00

Mustang mat with running horse on red, white & blue stripe.

Set of 4 \$24.95
Fronts, Only \$14.95

SHELBY AND MUSTANG CAR COVERS
- Greyshield, 100% cotton perfect fit.
..... \$72.00

TRUNK MATS - Reproduction mats are felt backed. Choice of plaid or speckled design. Specify year & design.
65-70 \$19.50

Original Ford, N.O.S. \$27.00

SPARE TIRE COVER
Speckled or Plaid \$10.95

DOOR PANELS
1965-68 All original colors \$52.00 ea.
AUTHENTIC MUSTANG UPHOLSTERY

-All colors available in all models for 1965, 1966, 1967, 1968. Standard type seat upholstery.

Complete set \$179.95
W/Bench seat \$199.95

Upholstery for two bucket bucket seats \$129.95

Upholstery for one bucket seat \$67.95

PONY INTERIOR SEAT UPHOLSTERY

-1965-66. The most authentic reproduction of the pony interior is now available. Special attention has been given to the reproduction of the pony insert resulting in a duplication that matches the original in all details.

Upholstery for two bucket seats \$159.00

Upholstery for one bucket seat \$89.00

Complete upholstery for two buckets and back seat \$244.00

Quarter trim upholstery \$39.00 Per Set

MUSTANG HEADLINERS - All original colors available.

65-73 Moonskin \$35.95
Installation Kit \$2.50

REPRODUCTION KICK PANELS - Available in black, red, blue, white and parchment.

65-68 Coupe, Conv., 2+2 \$29.95

CONVERTIBLE TOPS - Our top quality tops are guaranteed for 3 years against defects in material or workmanship. Tops include plastic curtain and instructions. Available in black, white, blue or red.

..... \$92.00
Convertible Top Pads \$18.00

CONVERTIBLE WELL LINER - Fits in the area between rear seat and trunk. Available in black or white, perfect fit.

..... \$19.50

CONVERTIBLE TOP BOOTS - Exact reproduction of the original. Available for 1964-73 in white, black, ivy, gold, blue, red, palamino, light turquoise, parchment, dark red and light blue.

64-68 \$38.50
69-73 \$40.50

Storage bag for top boot \$4.95

Top boot studs, set of 17 \$8.00

Stud, retainers, set of 17 \$15.00

When Ordering: Add 10% For Shipping:
We have, or can get, virtually all Mustang parts and accessories available. We also have an enormous supply of obsolete goodies and used parts in stock. Call or write for specific needs. Look for us at Swap Meets throughout the year.

Mustang and Shelby Parts and Accessories

*Largest Inventory in the Northeast...
We have a lot of things you can't
get from Ford any more!*

TOLL FREE ORDER LINE
1-800-243-7278

Fast UPS Service

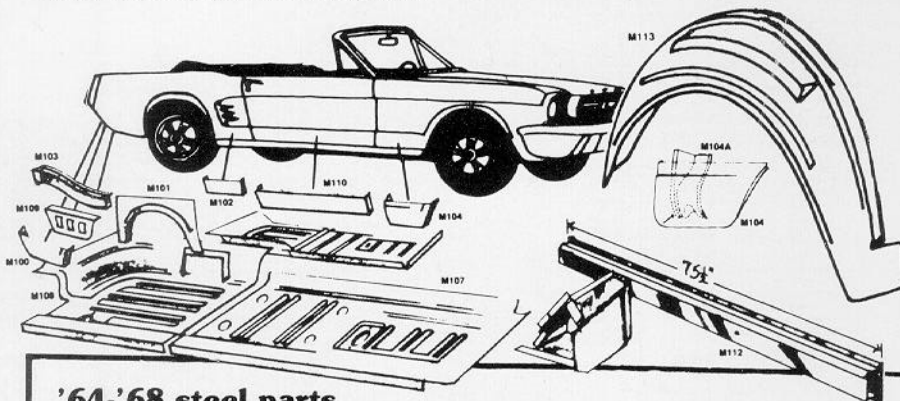

'64-'68 steel parts

M100 64-66 LOWER REAR CORNER \$25.00 ea. has original contour on back, bottom, and wheel opening. 7 1/2" high.

M100A 64-66 LOWER REAR QUARTER \$31.00 ea. has original contour on back, bottom and wheel opening. More than 12" high with offset along top edge.

M200 67-68 LOWER REAR QUARTER \$33.00 ea. has original contour on back, bottom and wheel opening. 13" high with offset.

M101 64-66 REAR WHEEL FLAIR \$33.00 ea. has original contour with 3/4" inner flange.

M201 67-68 REAR WHEEL FLAIR \$33.00 ea. same as early with top offset.

M102 64-66 LOWER PANEL IN FRONT OF REAR WHEEL \$11.00 ea. has lower portion of wheel opening with bottom and front edge included.

M103 64-70 REAR FRAME RAIL \$51.00 ea. has original contour, made from heavy 14 gauge steel with mig welded spring mount. 28" long. Specify right or left, body style.

M104 64-66 LOWER REAR CORNER OF FRONT FENDER \$25.00 ea. includes rear edge to form door opening, extends to 1 1/2" above horizontal body line. 1" high.

M104A 64-66 INNER STRUCTURE LOWER REAR CORNER OF FRONT FENDER \$18.00 ea. exact duplicate of inner structure.

M204 67-68 LOWER REAR CORNER OF FRONT FENDER \$26.00 ea. includes rear edge to form door opening 12" high.

M204A 67-68 INNER STRUCTURE LOWER REAR CORNER OF FRONT FENDER \$18.00 ea. exact duplicate of inner structure.

M106 64-68 SHORT FRONT FLOOR PAN \$44.00 ea. Section in front of seat, extends 4-5" up toward pedals.

M107 64-68 LONG FRONT FLOOR PAN \$49.00 ea. Section under and in front of front seat extends 4-5" up toward pedals.

M108 64-70 REAR FLOOR PAN \$49.00 ea. Section extends behind front seat 21". Original contour extends under lip of rear seat, also extends above seat belt hole on tunnel.

ON FLOORS seat holes and cleanout holes are stamped out completely, like originals.

M111 64-70 DRAIN HOLE COVERLET \$3.25 ea. or \$11.00 set of 4 galvanized, die stamped like original.

M109 64-68 INNER PANEL LOWER REAR CORNER \$21.00 ea. has original ribs, also breaks 1" over on trunk floor.

M110 64-66 LOWER DOOR SKIN \$30.00 ea. wraps around front, back & bottom edges. Has original contour 7 1/2" high.

M112 64-68 INNER ROCKER PANEL \$61.00 ea. conv. renews structural strength of convertible.

Factory 64-70 INNER WHEELHOUSE \$48.00.

M113 64-66 OUTER WHEELHOUSE \$59.00 ea. die stamped in our shops, highest quality.

Factory 67-68 OUTER WHEELHOUSE \$48.00 ea.

M114 64-68 TORQUE BOX \$65.00 ea. conv., die stamped 14 gauge steel.

69-70 FASTBACK OR CONVERTIBLE QUARTER PANELS \$199.00 ea. Specify model.

64-68 REPRODUCTION QUARTER PANELS \$70.00 ea.

M300 69-70 LOWER REAR CORNER \$33.00 ea. Specify Fastback or Conv.

1965-1968 MUSTANG

1965 Full wheel cover, 13" or 14" ea \$19.00
 1966 Full wheel cover ea 19.00
 1965-66 Wire wheel cover (blue center) ...
 ea 104.00
 Spinner and blue center only for above
 ea 24.50
 1966 Trim ring for styled steel wheels
 24.50
 1965-66 Red center for styled steel wheels ...
 15.00
 1965-67 Lug nuts for styled steel wheels ...
 ea 2.95
 1967 Trim ring for styled steel wheels
 24.50
 1967 Blue center for styled steel wheels ...
 9.00
 1967 Full wheel cover 19.00
 1967-68 Wire wheel cover (red center)
 87.50
 Red center only for above 15.00
 1968 Full wheel cover (plain center)
 23.50
 1968 Full wheel cover (red center) .. 38.00
 1968 Trim ring for styled steel wheel. . . 24.50
 1966 Chrome hi-po air cleaner 22.50
 1965-66 GT exhaust trumpets ... pair 88.50
 1965-66 Chrome trim for GT trumpets
 ea 8.75
 1965-68 GT or std rear valance, specify year .
 42.50
 1965-66 Front bumper 95.00
 1965-66 Rear bumper 95.00
 1967-68 Front bumper 95.00
 1967-68 Rear bumper 95.00
 1965-66 Bumper guards (set of 4) ... 64.00
 1965-68 Front valance, specify year. . . 55.00
 1965-66 Rocker panel molding ... ea 43.50
 1967-68 Rocker panel molding ... ea 26.00
 1965 Quarter panel ornament 14.50
 1966 Quarter panel ornament 16.00
 1965-66 Outside door handles ea 11.50
 1967-68 Outside door handles ea 13.50
 1965-66 Tail lamp bezels ea 12.65
 1967-68 Tail lamp bezels, 6 reqd. . . ea 11.00
 1965 Grille mesh, specify std or GT .. 47.50
 1966 Grille 68.50
 1967 Grille 63.50
 1965-67 GT grille bars, specify year
 pr 135.00
 1965-67 Fog light assembly ea 55.00
 1965 Grille ornament "Horse and Corral" ...
 54.00
 1965 Grille bars, std ea 19.50
 1965-68 Fenders, specify year, side
 ea 145.00
 1965-68 Coupe quarter panels, specify year .
 160.00

1965-66 Convertible quarter panel. 160.00
 1965-66 Fastback quarter panel ... 185.00
 1965-66 Dash bezel, specify yr & type. 26.75
 1967 Dash bezel, black 23.75
 1967 Dash bezel, brushed alum 2.00
 1968 Dash bezel, black 42.00
 1968 Dash bezel, woodgrain 42.00
 1965 Dash pads (black, red, blue) .. 110.00
 1966 Dash pads (black, burgundy, blue) ...
 110.00
 1965-66 Armrest pads, specify color
 ea 16.00
 1965-66 Chrome armrest bases. each 14.00
 1967-68 Armrest pads, specify year, color ...
 ea 23.00
 1965-68 Fuel tank 82.50
 1965-66 Trunk mats, specify year, body type .
 32.50
 1965-66 Steering wheel, black 68.50
 1965-66 Horn ring for std wheel 28.95
 1965-67 Horn ring for woodgrain wheel ...
 23.00
 1965-66 Parking lamp assembly 26.95
 1967-68 Parking lamp assembly 26.95
 1965-68 Back-up lamp assy, specify yr. 27.60
 1965-66 Ign, door lock set w/2 "pony" keys
 22.50
 1965-68 Step plates (specify body type) ...
 pr 25.00
 1965-68 Accessory step plates (outer)
 pr 38.50
 1967-68 Power brake kit, for drum brakes ...
 135.00
 Cobra alum valve covers, 260-302. . pr 68.00
 Cobra alum valve covers, 352-428. . pr 110.00
 1965-66 Hood 195.00
 1967-68 Hood (specify type) 195.00
 1965-66 Radiator (specify engine) .. 165.00
 1965-68 Luggage rack (except fastback) ...
 130.00
 1966 Hardtop rear window defroster kit. 65.00
 1965-66 Rotunda tissue dispenser ... 45.00
 1965-66 Rotunda Jr tissue dispenser. . 45.00
 1967-68 Electric qtr mount antenna kit. 60.00
 1968-70 Chrome wheels, nice used. . ea 50.00
 1967 Styled steel wheels, nice used
 ea 100.00
 1967-68 Radiator, 289 engine 165.00
 1967 Antenna kit 60.00
 1966 Dash mount clock 75.00
 1965 Rally-Pac, 8-cyl, nice used ... 200.00
 1965 Foglamp switch, less knob 40.00
 1966 Foglamp switch, complete 60.00
 1965-66 Trailer hitch kit 125.00
 C6AZ 17A326-E, 6,000 Cobra tach .. 175.00
 1965-66 Door edge guard kits 25.00
 1965-66 Remote mirror kit 125.00
 Matching rh mirror 75.00

ACCESSORY PONY MATS

Available In:

White
 Blue
 Red
 Burgundy
 Black
 Green



Set of 4 \$45.00
 Front only \$0.00

MOLDED CARPET

Our molded carpets are the best available. All carpets are molded, serge bound, and jute backed as original. The correct heel pad and toe guard are color keyed.
 1964 1/2-68 (specify color and body style) \$95.00

REPAIR PANELS

1965-66 lower rear corner patch panel each \$21.90
 1965-66 inner panel for above each 17.00
 1965-66 rear frame rails (specify body type) each 44.50
Mustang Floors:
 Rears each \$48.50
 Long fronts each 49.50
 Short fronts each 39.00

DOOR PANELS 1965-1966-1967

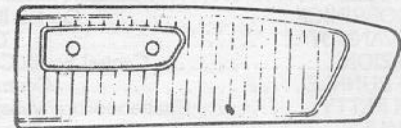

All Original Colors
 \$52 each
 Specify Year

STANDARD SEAT UPHOLSTERY 1965-1968

Bench seat, front \$149.95
 Complete set with bench front 199.95
 Complete set (two buckets and rear seat) 179.95
 Upholstery for two bucket seats 129.95
 Upholstery for one bucket seat 67.95

PONY INTERIOR 1965-66

Upholstery for two buckets \$159.00
 Upholstery for one bucket 89.00
 Complete set (two buckets and rear seat) 244.00

MANUALS

1965, 66, 67 or 68 each \$25.00
 "Mustang Does It" by Ray Miller, covers 1964 1/2-73 Mustang, 320 pages, 1,328 photographs, hardbound with cover \$27.50
 Parts catalogs: complete set of original Ford loose leaf parts catalogs, 1965-1972. Covers all models \$60.00

ALL PARTS ARE NEW UNLESS OTHERWISE NOTED

Please add 10% for shipping and handling (minimum \$2) except fenders, hoods and quarter panels, which will be shipped freight collect. Master Charge and VISA are accepted.

NEW MUSTANG CATALOG \$2.00

SATISFACTION GUARANTEED
 30-DAY RETURN



FORD PARTS WAREHOUSE

Courthouse Square, Liberty, KY 42539

PH: 606-787-5031



CLUB OFFICERS

1983 National Officers

BOB VICKERY	President
GORDON HARRISON	Vice President
SUE OSBORN & JANE SINGLETON	Co-Secretaries
BARBARA KOIVU & BERLIN PLESS	Co-Treasurers
ED HUNTER & KEN YEAGER	Sergeants-at-Arms
GEORGE WHITE	Chairman, Board of Directors
JOHN ROGERS	Parliamentarian
BILL DILLARD	National Head Judge
GORDON HARRISON	Magazine Publisher

REGIONAL GROUP DIRECTORS

ART E. SCHEELER	Alberta Mustangs
DON TRAVER	Aloha Mustang & Shelby Club of Hawaii
RANDAL J. LANDRY	Ark-La-Tex Pony Express
JERRY CATON	Carolina Region Mustang Club
KEN DANIEL	Central Florida Regional Mustang Club
BOB DOBRINICK	Central Illinois Regional Chapter
GREG VANNOY	Central Jersey Mustangs
CRAIG ZION	Central South Carolina Regional Group
DAVID RUNKLE	Centre Region Mustang Club
FRANK PETTY	Chattahoochee Valley Region Mustang Club
ROB RAVEN	Copper State Mustang Club
RICHARD PITTMAN	Eastern North Carolina Regional Group
FRED GLAZIER, JR.	First Pennsylvania Regional Group
ERNE STOUT	First Tennessee Regional Group
JIM PAYNE	The Foothills Regional Group
BOBBY DODD	Gate City Triad Club
GORDON HARRISON	Georgia Regional Group
GIL BAUMGARTNER	Golden Hills Mustang Club
DAVID WALTERS	Gulf Coast Regional Group
BOB LACHMAIER	Hall of Fame Mustangers
HARREL McKINNEY	Heart of Dixie Mustang Club
TONY LAGONE	Hernando Countyw mustang Assn.
STEVE BILDERAIN	Highway Horsemen of Southern California
BILL TRIMPE	Hoosier Mustang Club
KERT MAUL	Kansas City Mustang Club
LONNIE HOGAN	Lakeway Mustang Club
MARK SHEHORN	Mid-America Regional Group
TOM HOYT	Mid-Missouri Mustangs
BOB MILLER	Mid-West Mustang Club
JACK WILBANKS	Mississippi Coast Stangers
BILL INGRAN	Model City Mustang Club of Anniston
BOB OVERBEY	Music City Regional Group
BILL LEWIS	Mustang of Buffalo
DAVID SPRY	Mustang Car Club of Omaha, Inc.
PHIL SMITHEY	Mustang Club of Las Vegas
GENE SCHWANDTNER	Mustang Club of Maryland
BOB KASPRZAK	Mustang Club of SW Michigan/N. Indiana
DON GILLESPIE	Mustang Owners' Club of SE Michigan
ED XIQUES	Mustangs of Memphis
RICH BORER	Northeast Nebraska Mustang Club
BOB MYERS	Northeastern Ohio Regional Group
LARRY GRASER	Northwest Ohio Regional Group
JOHN K. GRIFFITH, JR.	North Jersey Mustangs
ROBERT HALTERMAN	Old Dominion Mustang Club
NOAH YODER	Old Fort Mustangers
TED FUTSCHER	Peninsular Regional Group
SCOTT SEITZ	Pony Express River City Mustangs
BOB UNDERWOOD	Rio Grande Mustang Club
PERRY O. BLACKWELL	Rocket City Mustang Club
EDDIE CAHEELY	Scenic City Regional Group
JEFF FELTNER	Shenandoah Valley Mustang Club
OLEN BISHOP	Shoals Mustang Club
RICH RILEY	South Jersey Mustangs
KENNETH C. STANGE	Southern Illinois Mustang Association
MIKE LEWIS	Texas Panhandle Mustang Club
FRANK STITT	Three Rivers Regional Group
KEVIN McATEE	Treasure State Mustang Club

RICHARD HEHEMAN	Tri State Mustang
PAT VASSALLO	Valley Forge Mustang Club
DOUG OWEN	Volunteer Regional Group
LARRY E. FINCHER	West Georgia Regional Group
ROGER ADKINSON	Wiregrass Regional Group
WAYNE WITTE	The Wisconsin Early Mustangers

President's name appears when no Director's name has been sent to National Headquarters.

1983 National Board of Directors

(1/84)	A. W. AMANNS	Fairburn, GA
	BILL DILLARD	Calhoun, GA
	JIM FARLOW	Fairburn, GA
	TOM GATTIS	Conyers, GA
	GARY HARTTER	Marietta, GA
	GORDON HARRISON	Doraville, GA
	DAVID HICKS	Roswell, GA
	ED HUNTER	Powder Springs, GA
	JIM HUNTER	Powder Springs, GA
	BARBARA KOIVU	Stone Mountain, GA
	JACKIE MILLS	Morrow, GA
	MARJORIE PLESS	Roswell, GA
	GUS WINCHESTER	Lithonia, GA
	RUTH ANN WINCHESTER	Lithonia, GA
	EVELYN WOOD	Birmingham, AL
	HORACE WOOD	Birmingham, AL
(1/85)	JIM OSBORN	Lilburn, GA
	SUE OSBORN	Lilburn, GA
	MARY PARKS	Snellville, GA
	MEL PARKS	Snellville, GA
	BERLIN PLESS	Roswell, GA
	JOHN ROGERS	Decatur, GA
	JANE SINGLETON	Decatur, GA
	BOB VICKERY	Lithonia, GA
	TERESA VICKERY	Lithonia, GA
	BOBBIE WHITE	Smyrna, GA
	FRANK WHITE	Acworth, GA
	JACK YEAGER	Decatur, GA
	KEN YEAGER	Decatur, GA
(10/85)	GEORGE WHITE	Smyrna, GA

DISPLAY ADVERTISING RATES

ad	size	cost
1 page	7-5/16" w x 9-5/8" d	\$120
2/3 page	4-13/16" w x 9-5/8" d	100
1/2 page	7-5/16" w x 4-13/16" d	75
1/3 page	2-1/4" w x 9-5/8" d	55
1/4 page	3-5/8" w x 4-13/16" d	40
1/6 page	2-1/4" w x 4-13/16" d	25

These rates apply to CAMERA-READY copy only! Please add 30 percent to rates for non-camera-ready copy. The following discounts will apply to multiple insertions: 3X: 5 percent, 6X: 15 percent, 12X: 25 percent. Specific position (when available): plus 10 percent. Inside cover positions; plus 15 percent. Deadline for all ads is the 10th of the month prior to the cover date month, i.e. June 10 for the July issue. Payment must accompany ad. Please address all display advertising correspondence to Ad Manager, P.O. Box 447, Lithonia, Georgia 30058.

MUSTANG TIMES

The Official Publication of the Mustang Club of America

APRIL 1983

VOL. 7 NO. 4

Publisher
Gordon R. Harrison

Editor
Josie Knowles

Typography
Custom Composition
Stone Mountain, Georgia

Printing
DeKalb Litho
Avondale Estates, Georgia

Fulfillment
Computer Systems
& Solutions, Inc.
Avondale Estates, Georgia

National Head Judge
Bill Dillard
Rt. 4
Calhoun, GA 30701

National Regional Group Director
Horace A. Wood
3653 Altadena Drive
Birmingham, AL 35243
(205) 967-1705

Office Manager and Ad Manager
Teresa Vickery
P.O. Box 447
Lithonia, Georgia 30058
(404) 482-4822

TABLE OF CONTENTS

Club Officers	4
Event Calendar	10
President's Column	12
Judge's Word	12
Mail Bag	13
Pony Plates	15
Membership Application	17
Horse Show	18
Car on the Cover	20
Mustang History, Part VII	24
Southern National Entry Form	26
Sunsphere Grand National Entry Form	27
Regional Group News	29
Regional Groups	36
Classified Advertising	38
MCA Accessories	41
Wrap-Up	42

For any correspondence pertaining to new membership, club information, renewals, national club business, etc. please send your letter to the national club address:

The Mustang Club of America, Inc.
P.O. Box 447
Lithonia, GA 30058

Mustang Times (ISSN 0744-2572) is published monthly by the Mustang Club of America, Inc., 1470 Stephenson Road, Lithonia, Georgia 30058. Membership dues to the club are \$20 per year which includes \$15 for twelve monthly issues of *Mustang Times*. Second class postage paid at Lithonia, Georgia 30058 and at additional mailing offices. Postmaster: please send address changes to *Mustang Times*, P.O. Box 447, Lithonia, Georgia 30058.

It is requested that any transaction with the club, including dues payment, be made by check or money order made payable to the Mustang Club of America. Cash must be sent

at your own risk. Please notify the club of any change of address immediately and allow a minimum of six weeks.

For urgent business with the Mustang Club of America, the office phone is (404) 482-4822. This is answered from 8-12 a.m. Monday through Friday.

Mustang Times and The Mustang Club of America do not accept any responsibility for the accuracy of advertisements and/or advertisers. Any advertisers who have proved unreliable or who have been named in legitimate complaints from MCA members will not be allowed to advertise. Liability for clerical and/or typographical errors which may appear in *Mustang Times* is limited to the correction of same.



"America's Number One Manufacturer
Of Original-Style Molded Carpets"

We have
high quality,
original-style
carpets to
fit your...

Mustang

Coupes... Convertibles... Fastbacks... Fastbacks with Fold-Downs:

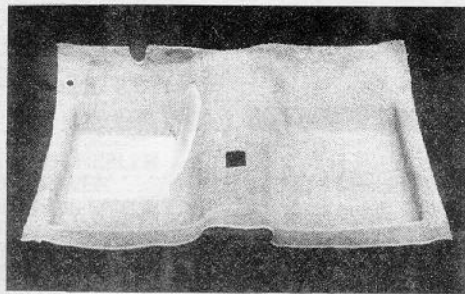

(Coupes or Convertibles)

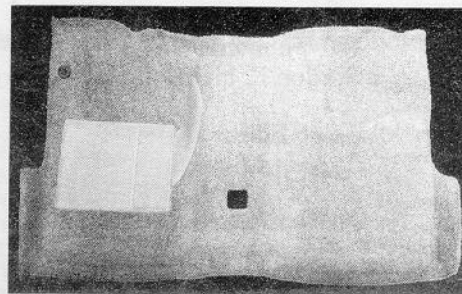
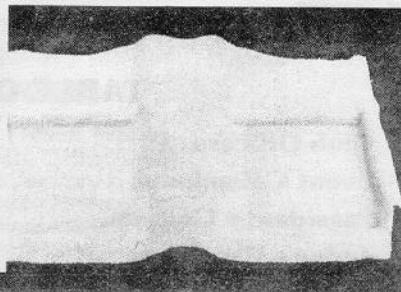

(Fastbacks)

'64 1/2-'68 MUSTANG Series:

Nylon loop and cut pile for
coupes, convertibles or fastbacks. SET \$95

Original-style 80/20
Rayon/Nylon loop. SET \$105

Fold-down package
for fastbacks. EACH \$15

Kick-pad carpets for
coupes and convertibles. SET \$14⁹⁵

NOTE: Mustang heel pads are produced from plastisol compound
in original Mustang molds and as close to 100 point as can
be made.

(Carpets and prices listed in this ad are also available
for '67-'73 Cougar Series.)

'69-'70 MUSTANG Series:

Nylon loop for coupes,
convertibles or fastbacks. SET \$95

Fold-down package
for fastbacks. EACH \$15

MACH-I Deluxe with
full insert package. SET \$160

'71-'73 MUSTANG Series:

Nylon loop for coupes
or fastbacks. SET \$95

Fold-down package
for fastbacks. EACH \$15

About Our Quality...

- We GUARANTEE that you've never seen a Mustang carpet that will compare to ours.
- All carpets are molded and trimmed to fit your car just like the originals.
- Easy Installation — perfect results every time.

- OEM quality, fit and appearance.
- We offer the fold-down carpet in a die-cut package which includes the small corner panels with serged edges. Each panel is die-cut for precision fit. No cutting or fitting required.

DEALER INQUIRIES WELCOME!

We ship UPS/C.O.D. anywhere in the Continental United States



Holland's

AUTO CUSTOM CARPETS

316 "J" Street, Anniston, Alabama 36201

OUR TOLL-FREE
ORDER NUMBER... **1-800-633-2358**

For Information: (205) 236-1118

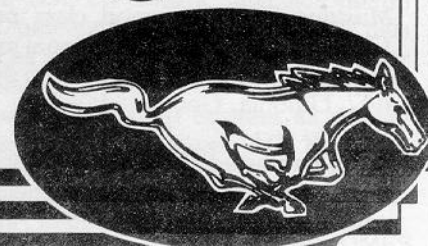

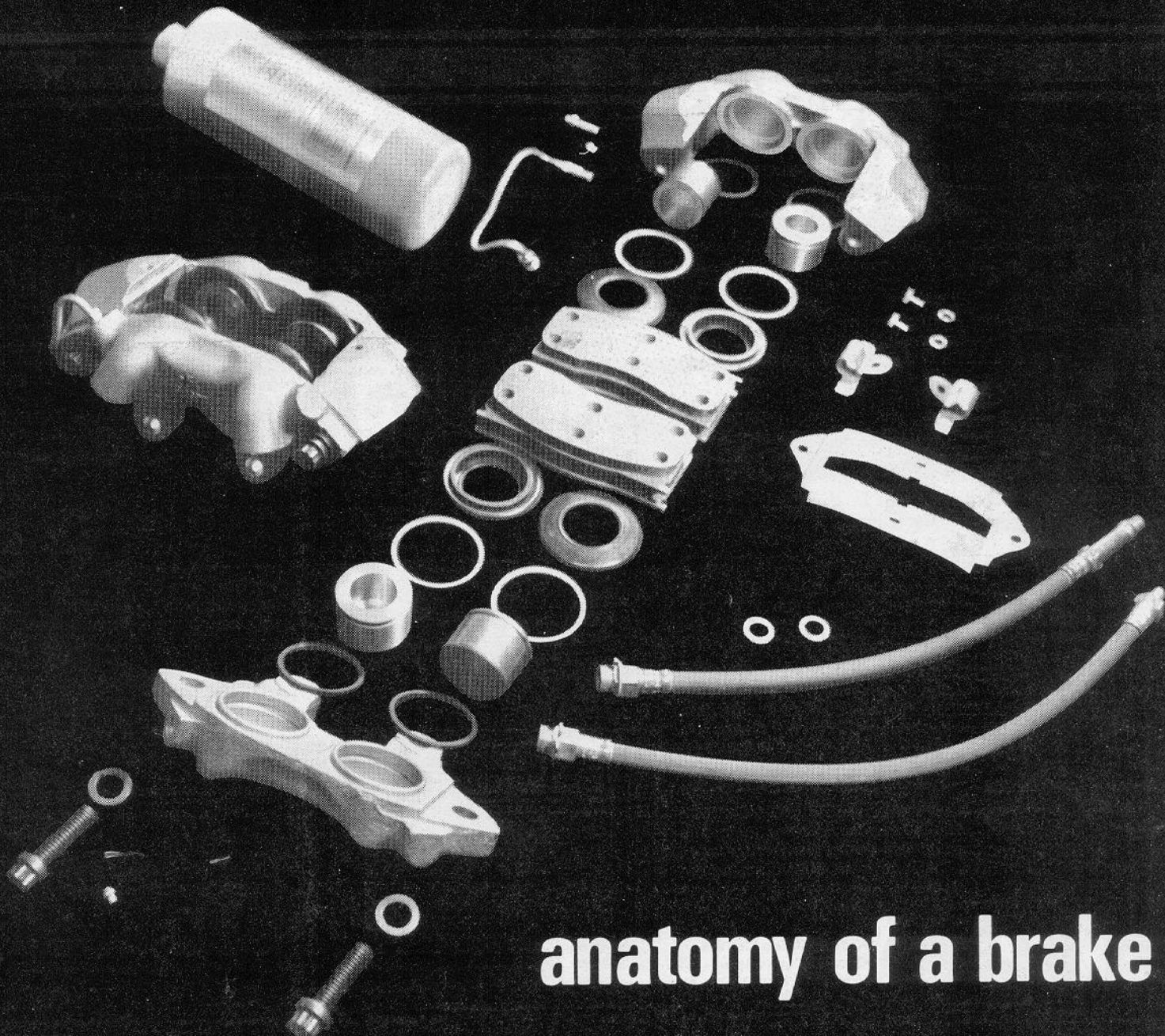

anatomy of a brake

stainless steel guts in a stainless steel skin —
 cure the sticking piston problem — permanently.
WE GUARANTEE IT!



**STAINLESS STEEL
 BRAKES CORP.**

©Stainless Steel Brakes Corp. 1983

Call Toll Free 800-448-7722
 In N.Y. (716) 759-8666

Stainless Steel Brakes Corp. / 11470 Main Road / Clarence, N.Y. 14031

Please send me more information about your stainless steel brake system products for 1965-67 Mustang, Shelby and T-Bird.

Name _____

Address _____

City _____ State _____ Zip Code _____

Model Year _____ MT-2

★ NEW ★ MUSTANG SALE CATALOG!

- ★ **10% OFF** DEALS CONTINUE!
- ★ **MORE NEW REPROS!**
- ★ **SPECIALS ON KITS!**
- ★ **FREE SHIPPING!**
ON UPS ORDERS OVER \$200

NEW PERFORMANCE SECTION!

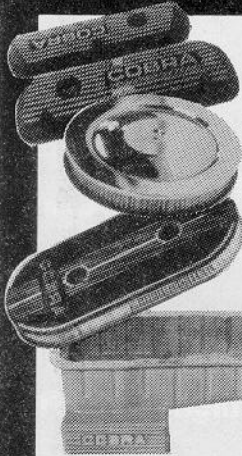

Hundreds of items, more coming!
Many Special Deals!
Some examples are listed:

- Tri Y Headers 149.95
- Cobra Oval Air Cleaner 69.95
- Chrome Air Cleaner 29.95
- Cobra Intake 195.60
- Cobra Oil Pan 259.95
- Cobra Valve Covers ea. 42.65
- Monte Carlo Bars 24.95
- Traction Bars 74.95

paddock west

446 TENNESSEE ST., DEPT. 1 REDLANDS, CA 92373

Call toll free except California, please have order ready. For information on orders and in-state orders, call (714) 798-4166.

800 854-8532



the paddock inc.

38 W. WARRICK, DEPT. 1 P.O. BOX 30, KNIGHTSTOWN, IN 46148

Call toll free except Indiana, please have order ready. For information on orders and in-state orders, call (317) 345-2131.

800 428-4319

SEND THIS COUPON TO THE INDIANA STORE FOR THE ONE-DOLLAR CATALOG THAT KEEPS ON COMING.

NAME _____

ADDRESS _____

CITY _____

STATE _____

ZIP _____

Send your name and address, with **ONE DOLLAR** and you'll receive our new sale catalog, plus being included in future mailings **FREE!**
IF YOU CAN'T WAIT - call 800-428-4319 and we'll send yours out right away first class and charge your Visa or Master Charge \$2.70. That also puts you on our permanent mailing list. **ACT NOW!**

\$1 CATALOG!



SEND COUPON

NOW!

FOR THE \$1 CATALOG THAT KEEPS ON COMING!

THE BOTTOM LINE! It all boils down to having what you want in stock, giving good service on your order, quick shipment, and a good return policy. We strive to be dependable with your money and needs for your car. Ask any one of our customers and then call us, we'll work hard at pleasing you.

OPEN THE DOOR



If You Don't
See What You
Want Here...
Call, We
Probably Have
It!

**TO AN ENTIRE WORLD OF
MUSTANG PARTS AND ACCESSORIES**

SPECIALIZING IN THE MANUFACTURING OF **DOOR PANEL SKINS**

- ★ 1965, 1966 Pony Molded Vinyl Door Panel Skinspr. **\$165.00**
- ★ 1967 Molded Vinyl Door Panel Skinspr. **\$165.00**
- ★ 1969 and 1970 Deluxe Molded Vinyl Door Panel Skins.pr. **\$295.00**
- ★ 1971 thru 1973 Deluxe Molded Vinyl Door Panel Skinspr. **\$295.00**
- ★ 1965 and 1966 Convertible or H/T Kick Panelspr. **\$30.00**
- ★ 1964, 1965 and 1966 Molded Carpet Setspr. **\$110.00**
- ★ Rear Area for F/Bea. **\$20.00**

*Also Carry Complete Line Of
Upholstery 65-68*

IN STOCK

- ★ Convertible Tops 65-73
- ★ All Rubber Seals 65-73
- ★ N.O.S. Chrome Parts 65-73
- ★ Rechromed Parts 65-73
- ★ Sheet Metal 65-73
- ★ Hard To Find Used Parts

Send For FREE Parts List

FOR ORDERS CALL: 1-800-327-3640 Outside Fla.

Bill B. Heshner

315 South Hopkins
Titusville, Florida 32780

305/267-4175

8:30 A.M. to 5:00 P.M.
Monday thru Friday

EVENT CALENDAR



- April 2 Mustang Collection Second Annual Road Rally, Dade County Youth Fairgrounds, Miami, Florida.
Host: Mustang Collection, Dade County Youth Fair. Call 264-4130
- April 7-10 Antique Auto Exposition, Charlotte Motor Speedway, Harrisburg, N.C.
- April 23-24 Third Annual Rocket City Mustang Show, Alabama Space and Rocket Center, Huntsville, Ala.
Host: Rocket City Mustang Club. Call (205) 881-2797.
- April 29-30, May 1 Lower Carolina Spring Fling, Charles Towne Landing State Park, Charleston, SC. Call (803) 556-9447.
- April 30 Third Annual Mustang Ford Car Show, Fairway Ford, 2323 Laurens Rd., Greenville, SC.
Host: Foothills Regional Group. Call (803) 877-0675.
- May 1 Antique Car Show & Ninth Swap Meet, Kankakee, Illinois County Fairgrounds.
Host: Kankakee Chapter Model T Ford Club International. Call (815) 432-5358 or (219) 865-2363.
- May 1 Fifth Annual Gettysburg Car Show & Parts Swap, Adams County Motors, Gettysburg, PA. Call (717) 637-6964
- May 7-8 Greater Vancouver Mustang Association's Second Annual Harrison Weekend, Harrison Hotel, Harrison Hot Springs, B.C. Write Craig Breckenridge, Greater Vancouver Mustang Association, 3715 Rupert St., Vancouver, B.C., Canada, V5M 3W2.
- May 14 Fourth Annual Rally & Swap Meet, Jeb Stuart Ford, Stuart, Va. Rain date, May 21.
Host: First Piedmont Regional Group
- May 20, 21, 22 Sixth Annual Indiana Spring Fling Parts Swap, Car Show and Autocross.
Host: Shelby American Automobile Club. Call (812) 988-7146.
- May 20, 21, 22 Third Annual Music City International Mustang Round-Up, Crown Ford, 646 Thompson Lane, Nashville.
Host: Music City Mustang Club. Call (615) 754-5770 or 758-8930.
- May 21 Second Annual Valley Forge MCA Show, Sloan Motors, 415 W. Lincoln Hwy., Exton, PA.
Host: Valley Forge Mustang Club.
- May 21 Second Annual Mustang Show and Parts Swap Meet, Grand Village Mall, Fairlanes Ave., Grandville, Michigan.
Host: West Michigan Mustang Club. Call (616) 784-5191 or 457-3896.
- May 21-22 First Annual Tri-State Shelby-Mustang Pocono Weekend Car Show & Swap Meet, Quality Inn, East Stroudsburg, Pennsylvania.
For more information, call Alec M. Garden, (201) 347-8216.
- May 21, 22 Twelfth Annual AACA Car Show, Cantey Building, State Fairgrounds, Columbia, SC.
Host: Antique Automobile Club of America, Sandlapper Region. Call (803) 799-1620.
- May 21, 22 Mustang Owners Club of Southeastern Michigan (MOCSEM) Swap Meet & All Ford Car Show, Atchinson Ford, Beleville, Mich. Call (313) 348-7549.
- May 22 North Jersey Mustang Club Third Annual Antique Car Show & Swap Meet, ITT Grounds, 390 Washington Ave., Nutley, N.J.
Host: North Jersey Mustang Club, Inc. Call (201) 272-4248 or 666-5917.
- May 22 Second Annual All Ford Car Show, Car Corral & Swap Meet, Kent State University Stadium, Kent, Ohio.
Host: NEO Mustang Club and KSU Dept. of Intercollegiate Athletics.
Call (216) 297-7136 or 459-1996.
- May 27-28 Third Annual March of Dimes Car Show, Jessamine Mall Shopping Center, Sumter SC.
For more information, call (803) 481-2563.
- May 28-29 North Texas Mustang Club, Regional Spring Meet, Car Show, Drag Race, Swap Meet, North Park Inn, 9300 N. Central Expressway, Dallas, TX.
Call (214) 331-2109 or 252-8747.

- May 28-29 Second Annual Southwest Invitational Mustang Meet, Frontier Ford, Albuquerque, NM.
Host: Mustang Owners Club. Call (505) 881-2715.
- May 29 First Annual Shelby-Cobra-Boss-Mustang Special Interest Ford Show and Flea Market, Leithsville, PA.
Fire House, Rte. 412, Hellertown, PA.
Host: Eastern Pennsylvania Region of SAAC. Call (215) 345-8010.
- June 5 Central Illinois Ford Day, Mustang Show and Swap Met, Bob Dennison Ford, U.S. 150 and Veterans Parkway, Bloomington, IL.
Host: Central Illinois Mustang Assn.
- June 12 Fifth Annual Mustang Car Show & Swap Meet, Northtown Ford, 455 E. Pershing Rd., Decatur, Ill.
Host: Central Illinois Regional Chapter. Call (217) 877-0604 or 428-6970. Rain date, June 19.
- June 17-19 Southern National Mustang Club of America Show, Biloxi, Mississippi.
Host: Mississippi Coast Stangers
- June 18 Third Annual Dealer's Day, Jack Byrne's Ford & Mercury Dealership, Mechanicville, NY
Host: Adirondack Shelby-Mustang Regional Club, Inc., SAAC. Call (518) 885-9013 or 371-6547 or 885-3536 after 5 PM.
- June 19 Antique Car Show, Msgr. Owens Memorial Park, Nutley, N.J. Includes Mustang Classes.
Host: Nutley Elks and North Jersey Mustang Club. Call (201) 667-7102.
- June 25 Second Annual Memphis Mustang Round-up, Lewis Ford, 529 Summer Ave., Memphis.
Host: Mustangs of Memphis. Call (901) 761-9309 or 388-3800.
- July 1 Old Fort Mustangers First Annual '64½-'73 Roundup and Corral Mustang Show, 5120 Speedway Dr., Ft. Wayne, In. Call (219) 745-0444 or 657-5875.
- July 23 Second Annual Rally & Swap Meet, Scenic Ford, Mt. Airy, N.C. Rain date, July 30.
Host: First Piedmont Regional Group.
- August 5-7 Sunsphere Grand National Mustang Club of America Show, Knoxville, Tennessee.
Host: Volunteer Regional Group.
- August 14 First Annual Clam Steam-Car Show, Krause's Halfmoon, Beach Grove, Clifton Park, NY
Host: Adirondack Shelby-Mustang Regional Club, Inc., SAAC. See phone nos. above.
- August 12-14 Fourth Annual Mid-America Mustang Roundup, Sapp Bros. Ford Center, West I-80, Omaha, Neb.
Host: Mustang Car Club of Omaha. Call (402) 426-9851
- August 12-14 Super Run '83, Tropicana Hotel Golf Course, Las Vegas, Nev.
- Sept. 2-4 Sixth Annual Dixie National Shelby Meet, Labor Day Weekend, Jackson, Miss. Call (601) 373-0054.
- Oct. 1 Second Annual Rally & Swap Meet, Mitchell-Howell Ford, Martinsville, VA. Rain date, Oct. 8.
Host: First Piedmont Regional Group.

MCA Members Get 10% Off

The Shamrock Inn and Chalet Motel invite MCA members and their families to Harrah's Swap Meet, June 30 through July 3 in Reno, Nevada. The Inn and Chalet's manager, John Gierke, Jr., claims to be an "old car nut" himself who has sold his cars and would enjoy seeing those of MCA members.

A 10% room rate discount is offered to Mustang Club of America members staying at the motels. There will be space and equipment available to clean cars, some covered parking with

security lighting for protection.

To get the 10% discount, members must show a current MCA membership card. The two motels are located side by side, just two blocks from the downtown casino and shopping area. Gierke says the motels offer clean

rooms, friendly service, free casino packages, direct dial phones, free ice, pets OK, some adjoining rooms, and much more. He advises advance reservations. For more information, phone (702) 786-5182 for the Shamrock, (702) 322-0405 for the Chalet.

PRESIDENT'S COLUMN

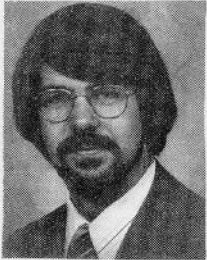

The Mustang Club of America boasts of being the largest Mustang Club in the world, which is true; but not only do we want to be the largest, we want to be the best.

Over the last year and a half, we have worked very hard at operating the club on a more professional level than in the past, with the *Mustang Times* being high on our list of things to improve and get out on a timely basis. Now we (myself and Board of Directors) feel that we have reached an acceptable performance level, we are going to sponsor a nationwide membership drive through our 70 or so regional groups. Starting on May 1, 1983, and running six months (through September 30, 1983) the Mustang Club of America will rebate (a highly visible word pertaining to the auto industry) \$5.00 per new member to the regional group that *collects* the new member's money and application and submits it to National Headquarters. Our definition of a *new* member is a person who has never been associated with MCA before or a past member who did not renew his/her membership and *has not* been on our roster for more than *one* year.

The regional group should collect these memberships and submit them to National Headquarters every two weeks, and we will send your rebate check once a month. We feel that this is an excellent opportunity for our groups to earn money as well as build their memberships. It is also a good opportunity for some of our groups to properly align themselves with our memberships rules. We are currently going into Spring and Summer which are our best two seasons, and with the Mustang currently the hottest collectible car on the market, it should be an easy task to attract new members. If your club needs additional membership applications, call or write to National Headquarters for these. Also, if your club is hosting some type of show or attending a large swap meet and car show, we will send you a box of *Mustang Times* to give away at

your event.

This membership drive is not only a good opportunity for our existing regional groups, but also an excellent opportunity for anyone who is considering starting a new group. As I stated before, we want to be the best as well as the biggest, and we will continue to try to improve on our club and the magazine. The next project is to improve the *Mustang Times* by includ-

ing more technical information and "how to" articles.

I hope that all of our groups will participate in this membership drive and make this project a huge success for our club.

Bob Vickary



Announces

"Blanket Protection"

A full stated amount insurance program designed to meet the needs of Mustang owners, and all collectors, including those specializing in late model and high performance automobiles.

Classic's new "BLANKET PROTECTION" program is affordably priced insurance that includes **LIABILITY** (in most states) and full stated amount coverage for fire, theft and collision.

If you drive your special car 2500 miles or less a year and you would like more information about this coverage call us toll free at:

(800) 631-1363
In Georgia: (404) 955-8787

Classic Insurance Agency • 1 Perimeter Way, N.W. • Atlanta, GA 30339

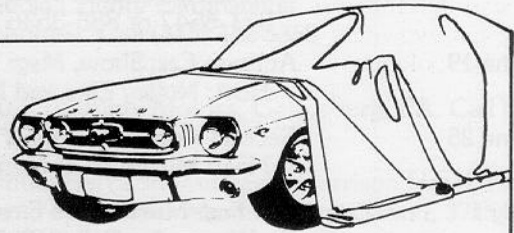

A Word From The Head Judge

I am glad to serve as new Head Judge. A lot of you know me. For those of you who don't, I have been around the MCA since day one. I am one of the original ten who gathered that day in April, 1976.

I have always enjoyed Mustangs, and to date I have around 25 plus (I lost count). I have shown in national and regional as well as local shows with a mild degree of success. So, as you can see, I know what it takes to build a nice car for show.

I have spent just as many hours as you have polishing, sanding and working.

I feel each of you knows that no one is perfect. There will always be people who will say "The Judge missed this on

my car", or "The Judge did not notice the wrong motor date" on their competitor's car. Things like this do happen, and the ones who complain the most have only once or *never* judged a national show.

A lot of people showing have never even tried or asked to take a judging test.

I want to see more people take the test. These tests are not perfect, but what test is? If we have more certified judges I feel everyone will feel better after a show.

Judging is the most criticized job and the hardest at *any* show. I would like to see judging become an honor that people volunteer for, not a job you

continued on page 13

Head Judge Continued

have to draft people for. You would not know at show time there are between 400 and 500 (very quick and very rough count) certified judges.

In conclusion, I want everybody to go to the shows and show, if at all possible. Judging improves the breed, and if you don't think so, just notice how much the cars have improved in the last two years alone.

I am looking forward to seeing all of your this year.

Bill Dillard

The Resurrected

We all know how much new cars cost, and there are people that go out and get a new car almost every year. If you can't afford to do this, and may have been wondering where these old run-down cars go after they get to the dealer's. Some of them go to the final resting place. Like you have seen on T.V., the Auto Undertaker in Hollywood, Fla. who acts just like the minister does at a funeral home when he takes old rusted-out cars to the junk yard.

If you don't like to take your auto to the final resting place, there are people out there like my dad, that goes to this final resting place and gets these old run-down, rusted-out cars. He takes these cars home and restores them to show-room type cars. Once this is done, they look and run just as good or better than the new ones. Instead of being an Auto Undertaker, he's a regenerator of old cars.

Just recently, he did this to an old rusted-out, half-burned '65 Ford Mustang convertible, with no wheels or engine in it. After putting new sheet metal in it and re-building the engine, and putting new paint on it, it was just like or better than a new one. As a matter of fact, it runs better than the new ones do. So, don't take your auto to the Auto Undertaker, just give your auto T.L.C. (Tender Loving Care). It will pay for itself in the long run. Just ask the people that do this.

Phillip A. Higley
Ottawa, Ohio 45875

Ponies in Pastures...again

I have had the same trouble that many MCA members have had in the past.

You are driving down the road and see a Mustang sitting in somebody's yard, not in too good of shape. Well, after driving past two or three other times, it is still sitting there, and you stop in to see if they would be willing to part with that pony. (Usually these type of ponies are in the condition of needing a minor restoration but are not too far gone to be used as parts).

Well, they also say that they are going to fix them up, but when you drive past in a year, they are still sitting there rusting.

In the area that I live there are a lot of these cases. For instance: '70 BOSS 302 being driven daily, snow or rain. A '67 GT 350 Shelby just sitting in a driveway, nothing being done to it, other than letting it rust. These are just a few examples.

I feel that if you are not going to fix them up, why not sell them to somebody that will?

Isn't there anything we can do as a club to help get these Mustangs either

into the hands of people that will restore them or offer the people that have them help in restoring them? In my opinion, it's a waste to leave them like they are right now.

David Bowers
Oelwein, Iowa

Picture, Anyone?

I would like to have a picture of an "original '66 Mustang convertible with fender skirts." If it's in a book, I'll buy the book. Please, let me know. If you don't know, please put ad in *Mustang Times*.

R. L. McKinley
2225 Winston Ave.
Louisville, KY. 40205

Likes Us

I would just like to say that I think Mustang Club of America is a fine organization. Plus the fact that you guys print a wonderful magazine. I own a '65 Mustang which I bought ten years ago for \$75.00, and it still runs like new.

Karl J. Bennett
Fairfield, CA.

Thanks for writing, Karl.

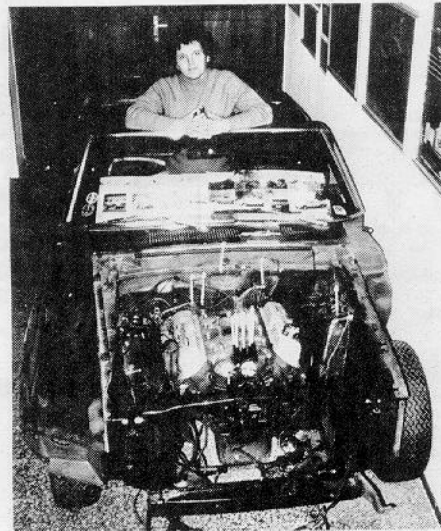

On October 25, 1982, in Telnice, Czechoslovakia, Frantisek Snobl celebrated the fourteenth birthday of his Mustang, born October 25, 1968, in Metuchen, New Jersey. (Thanks, Jim Smart!) Can anyone find the fourteen candles? Look for an update on Snobl and the sad plight of his Mustang on page 42.

Larry's Mustang Parts

OVER
5000
PARTS AVAILABLE

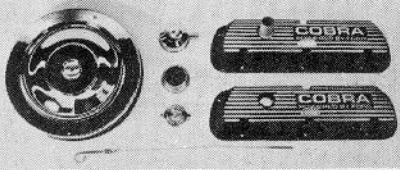

Engine Dress-up Kit—65/73, 260, 289, 302, 351W..... 124.95

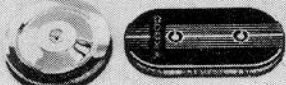

Air Cleaners—Hi-Po 39.95
—Cobra, single or dual 4bbl..... 79.95

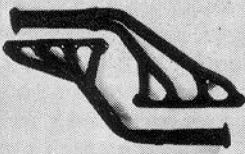

Tri-Y Headers—with installation parts 139.95

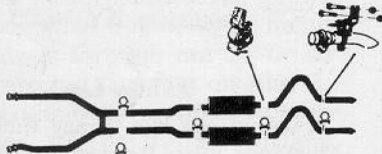

Dual Exhaust Installation Kit—for most years.
(Phone for price and availability)

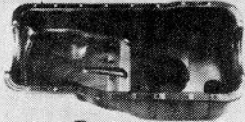

Oil Pan Kit—65/71, 260, 289, 302 93.95

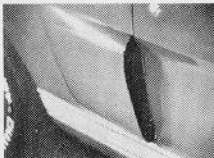

Shelby Scoops—65/66 6T350, fiberglass ... pr. 34.95

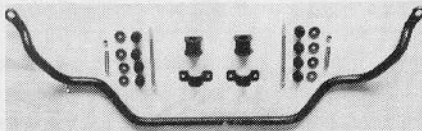

Shelby Type Sway Bar Kit—heavy duty 99.95

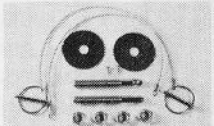

Hood Latch Kit—65/66 14.95

To place parts orders, please call the Toll Free numbers. For your FREE price list, please write and be sure to specify which price list you need (55-57 T-Bird or 65-73 Mustang).

PRICES SUBJECT TO CHANGE WITHOUT NOTICE

FREE PRICE LIST

LARRY'S T-BIRD & MUSTANG PARTS INC.
new/used parts • authentic upholstery
PHONE TOLL FREE 800-854-0393
In California call 714-871-6432
511 S. RAYMOND AVE. • FULLERTON, CA 92631



GT Grille Bars and Lamps Kit—65/66 189.95
—67 189.95



Gas Cap—65 Standard 34.95
—66 GT 36.95
—66 Standard 34.95



Wood Grain Dash Kit—65/66 32.95

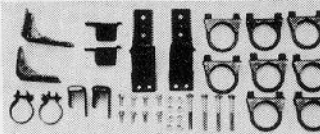

Dual Exhaust Hardware Kit—65/66 69.95

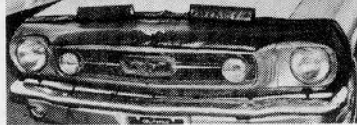

Larry's Mustang Bra—65/73 67.50

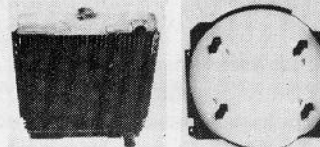

Heavy Duty Radiator—(Phone for price and availability)
Extra Cooling Fan Shroud Kit—65/66, 289 32.95

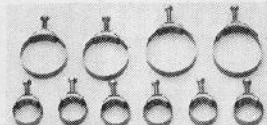

Radiator Hose Clamp Kit—65/73 original type. 15.00

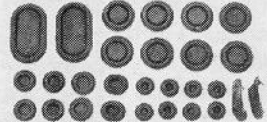

Rubber Plug and Grommet Kit—65/66 21.35
—65/66 with A/C 26.35



Export Brace—65/70 40.55

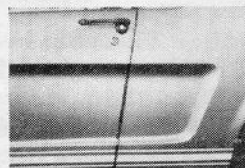

Door Edge Guards—65/66, stainless steel. . . 19.95

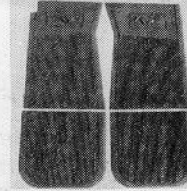

Rubber Throw Mats—65/73 set 45.00

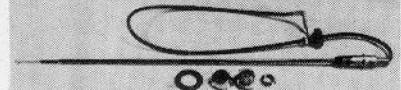

Radio Antenna—65/67 29.50



Battery and Starter Cable Kit—65/66, 8 cyl. 49.95

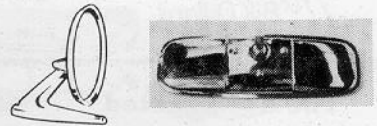

Mirror Assembly—65/66, outside 34.95
—65/66, inside 21.95



License Plate Frame—65/73 ea. 4.00



Air Conditioner Register—65/66, evaporator ... 24.95

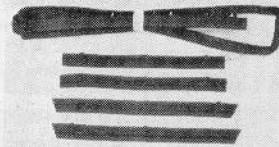

Folding Top Weatherstrip Kit—65/68 94.95

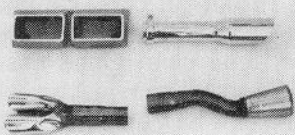

Tail Pipe Extension—(Phone for price)

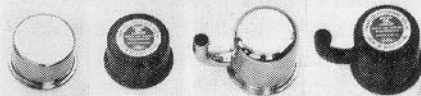

Oil Breather Caps—65/66
Chrome—open emission system 9.95
Black—open emission system 8.95
Chrome—closed emission system 11.95
Black—closed emission system 9.95



Mustang Patch Panels—most panels for most years
(Phone for price and availability)

Complete Upholstery including seat covers, headliners and door panels.

Doyle Ingram of Oxford, Alabama, owns the **1965 GT** coupe. Kenneth W. O'Dell of Greensboro, North Carolina, says he'd love his **KWO's '66** to be the first "First in Flight" personalized tag honoring the Wright Brothers to be seen in *Mustang Times*. **PONY GT** belongs to Freemon and Margaret Fritsche of Percy, Illinois. **MACH-10** is Ken Mosby Jr.'s of Levittown, Pennsylvania, along with the 1969 428 CJ RAM Air that goes with it. **29B 1965** belongs to Pat Hall of Deatsville, Alabama, and **SHELBY** identifies the 1968 Shelby GT500KR of Carl Hubbard of Montgomery.



FINE MOLDED MUSTANG CARPET

For Mustang Club of America Members Only!!!

1964½ to 1973

\$79⁰⁰

Per Set
Front & Rear



FOR HARD TOPS ONLY

+

15% Freight & Handling

Need 5 or More Sets?

Call for Special Value Discounts

Why Pay \$110⁰⁰? Or More . . .

- Sold to Mustang Club of America Members only at this price (send Member No. when ordering)
- Positively NONE Sold to Dealers
- 80/20 Rayon/Nylon
- ½" Backing
- Correct Heel Pad
- Easy Installation
- Show Room Finish
- One Year Guarantee
- No C.O.D. at this Price
- Allow 10' to 20 Days Delivery
- Master/Visa Excepted
- Other Ford Carpet at Same Price

ALL FORD CARPET & TRIM

P.O. Box 545

West Columbia, S.C. 29171

HOTLINES 1-803-794-8300 or 1-803-356-3600

Here It Is!

Wilmot & Finnegen are proud to introduce the original type fuel line bracket for the 289 and 302. Built to exact specifications as shown on page 86 of "Mustang Does It."

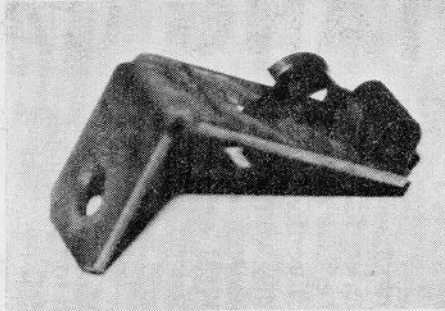

This is one of the many items available through Wilmot & Finnegen Vintage Mustangs. The price is \$10.00, add \$1.00 for shipping and handling. Items mailed pre-paid only. Call or write us for your every Mustang need.

**Wilmot & Finnegen
Vintage Mustangs
115 Ansley Ct.
Roswell, Ga. 30076**

Phone (404) 998-9304 9:00 AM - 9:00 PM 7 days per week

MEMBERSHIP APPLICATION

THE MUSTANG CLUB OF AMERICA

Yes!! I want to join the most responsive and fastest growing organization in the world dedicated to the preservation, history, and enjoyment of the original ponycar, the 1964½-1973 Ford Mustang in all its shapes and styles, years and models. Enclosed is \$20 for US or Canada member or \$40 for foreign member (US funds only in all cases). Dues include \$15 for twelve monthly issues of the *Mustang Times*. Please send my new member's packet immediately and also send the first of my twelve issues of the *Mustang Times* as soon as possible.

**send to: Mustang Club of America,
P.O. Box 447, Lithonia, Georgia 30058**

name _____ spouse _____

address _____

city, state, zip code _____

cars owned _____

if regional group member, which? _____

OWNERSHIP NOT ESSENTIAL — ENTHUSIASM IS!

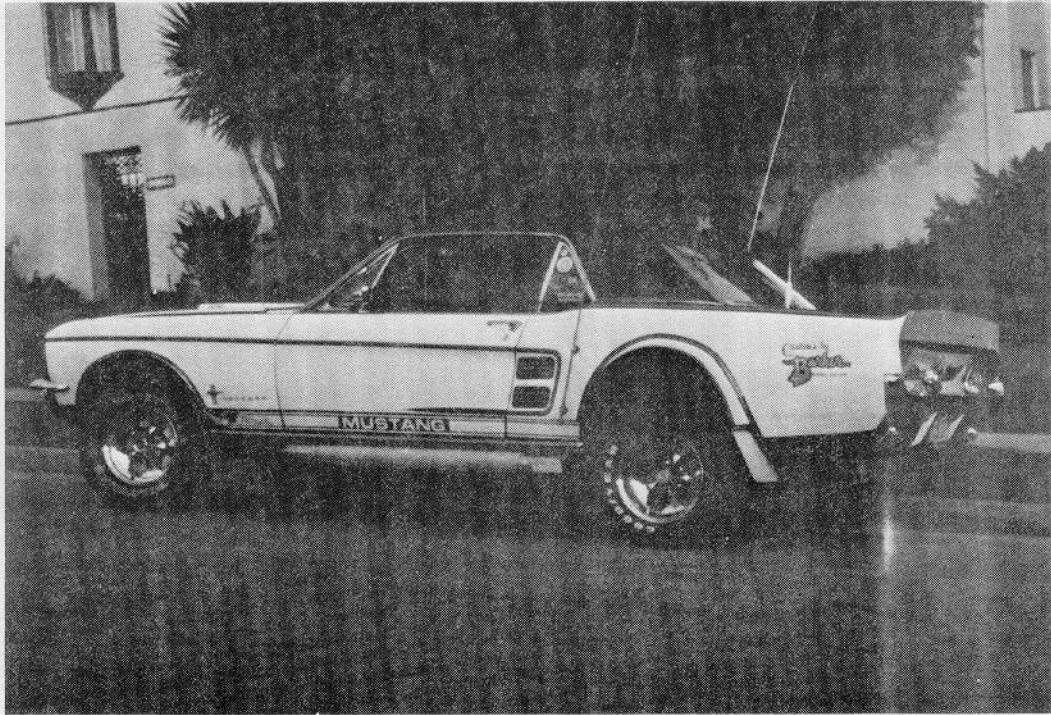

Bruce Barker, recently of Los Angeles and now of Bethel, Alaska, says his pony was greedy for some recognition, and who could refuse such a memorable Mustang? The 1967 model sports a 351C, C-6 transmission,

“Shaker” scoop, 9” rearend, power antennas, sunroof, AM/FM cassette/8 track, TV (Believe it!), CB, police scanner. The exterior is white with blue iridescent striping; the interior is

blue crushed velvet. Bruce did all the bodywork, painting and interiorwork himself. He says the car was raised approximately 9” all around to accommodate lousy Alaskan roads.

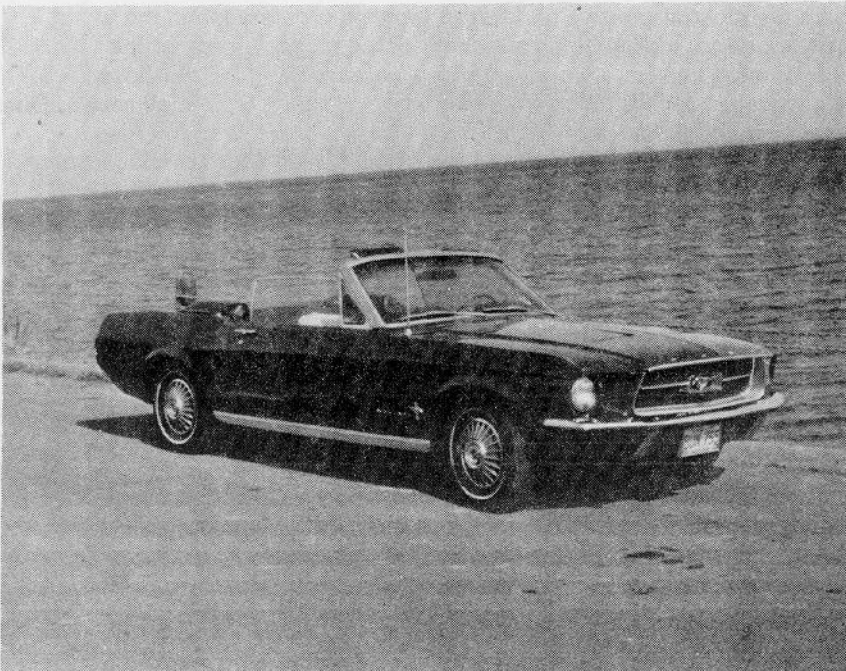

This 1967 candyapple red convertible belongs to Ted Appelquest of Duluth, Minnesota. That’s Lake Superior in the background.

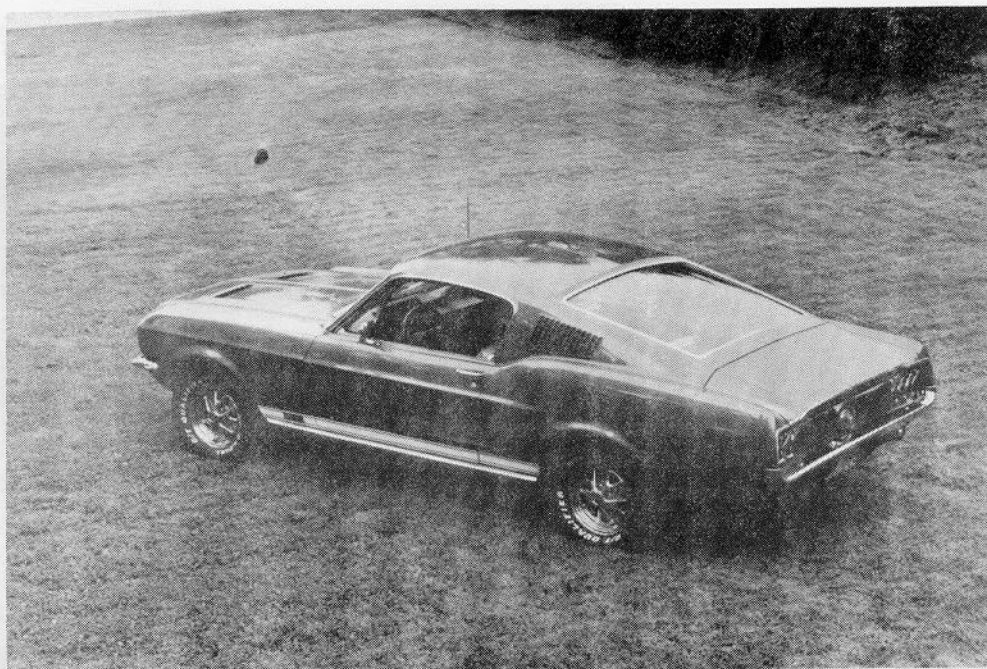

"I purchased my pony car four days before my nineteenth birthday in March, 1980," says Joseph Sage of Libertyville, Illinois. "When I got it, it was covered in mud, and the interior was much the same. So, I broke out the wax and polished every inch of the car back to its original beauty."

He's speaking of his 1967 Mustang 2 + 2 GT fastback with two-tone deluxe blue interior, overhead console, swing-a-way tilt steering wheel and fog lights. This beauty is powered by a HO 390, boasting the chrome package, four speed, and a rear axle ratio of 3.00:1 locking differential. The exterior is Acapulco blue with white stripes, set off by styled steel wheels.

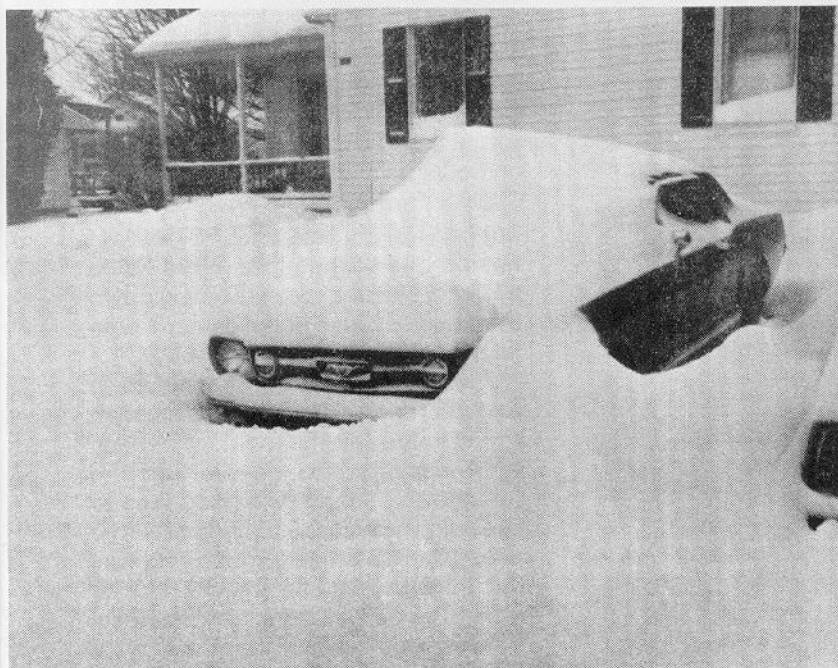

Linda Bowes, secretary of the First Pennsylvania Mustang Club and a cherished regular contributor to the magazine, thought that us "lucky Southerners" would like to see just what a Mustang must go through during winters up North. This picture was taken the day after the "Blizzard of '83", and she titled it, "Mustangs Do Survive Blizzards!"



Collector's Choice: 1967 Convertible

By Bob Feld

During the summer of 1980, while driving on the usual route I take through Bucks County, Pennsylvania to an apartment development that I manage, I kept seeing a dark green '67 Mustang convertible always parked in the same far corner of this shopping center parking lot. The car was a sorry sight; the rear end had been raised and two large wide racing wheels put on it; the rusted bumpers were painted black; the top looked like a couple of old raincoats sewn together; all the dents were painted an off-color with a paint brush, and the car looked like a crazy patchwork quilt.

The reason the car kept catching my eye was that it had GT fog lamps in the grille that appeared to be factory installed. One day while passing, I just drove in the parking lot and gave the car a fast "once-over". On the plus side of this "sad-sack" was a factory AM/FM radio, center console, wood steering wheel, power top, steering and factory disc brakes, and best of all — a real nice Palomino tan deluxe interior. Even at a quick glance I could see a partly faded white GT stripe above the rocker panel on one side, a dented GT fender badge, and although the exhaust was pretty beat up, I

noticed the chrome ends of the twin tips on one of the pipes. Here was a perfect case of a nice GT going down the drain because of the owner's non-interest in Mustangs as a hobby.

Several weeks later, I happened to pass there, and I noticed a young man sitting in the car, the top down, eating what appeared to be his lunch. I thought this would be a good time to speak to the owner and find out a little about the car's background. He was the third owner and knew both the others, as the car came from the local Ford agency just about one mile from where we were talking. He was quite

curious as to my interest in his car, as I was obviously twice his age or more, and all I could do was tell him the truth — I just like Mustangs. He told me he had the car for three years and that he didn't have any extra bucks to put into the car other than just keep it running.

When I left, I naturally asked him if he wanted to sell the car and was quite surprised by his answer. "No," he said, "I hear Mustangs are worth a lot of money these days." Nevertheless, I gave him my business card and told him if he ever wanted to sell it, to give me a call. For the next month I kept seeing the car in the parking lot and was half glad that he didn't want to sell it; and yet, I was dying to take on the challenge of restoring that car. Shortly thereafter, as I was opening the door to my office, the telephone rang. A voice said, "Is this the guy who likes Mustangs?" I laughed, said yes, and he proceeded to tell me that for personal reasons he needed to sell the Mustang "fast".

I met him that same day and before talking price I wanted to drive the car. This was a real experience — I couldn't believe what I was driving — the clutch was shot, reverse was gone, the ball joints and shocks were gone, and frankly, it was a little scary just to be sitting behind the wheel of this machine. The real "topper" came when he told me he wanted \$2,000, and that was his firm price. I told him I wasn't interested at that price, and he quickly told me that the car would be gone in a week. I noticed his ad in the local papers, but apparently, all other lookers weren't thrilled by this "wreck" for that price. The following week he called again and we made a deal at \$850 — which was a fair price either way.

In spite of all the problems with the car, I was happy to get it and immediately started collecting parts in order to bring it back to what it should look like. That winter, I spent a lot of time doing all of the mechanics, and the following summer, I had a beautiful lacquer paint job done in the original dark green metallic color.

Everything I have put on the car is all new old stock Ford, and with a new top, new carpets, steel style wheels

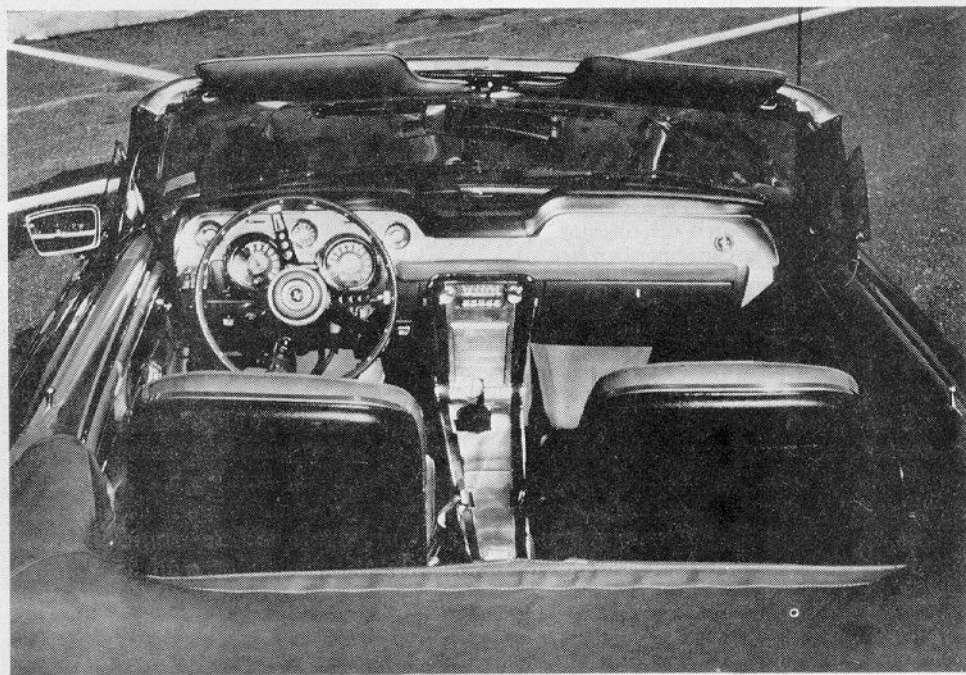

CAR ON THE COVER

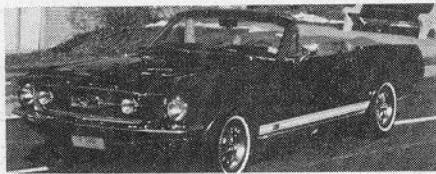

and tires, the car looks and is show room new.

The car is a 4-speed, 289 four barrel, and I really enjoy driving the car as it is quick and handles well.

Before taking on this project, I had restored a '64¼ convertible 6 cylinder, and two '65 convertibles (one automatic, and one a 4-speed) as part of my collection. Since doing the GT convertible, I have just about finished a '67 GTA fastback and a '68 GT convertible.

With these six cars in the collection, I don't intend to do any more restorations, as my weekends are taken up just doing maintenance and cleaning work. There is only one more Mustang that I would like to add to the collection some day, and that's a Shelby convertible, but I'd like to just buy it restored or find a nice original.

Like most car buffs, I get a tremendous amount of satisfaction out of seeing the potential of a classic in a beat-up car, buying it, and putting in all the time, effort and money to try and make it as good or better than when it was in the Ford agency showroom.

I would like to give my thanks to Don Sassman of Doylestown, a friend and professional Ford mechanic, who has helped me with many difficult restoration problems.

Bob Feld, 59, Melrose Park, Pennsylvania, Builder/Developer, has been a car collector and restorer as long as he can remember. He has also owned and driven convertibles since his very first car and, for some reason, they still appeal to him the most.

He started restoring 1930 Model "A" Roadsters and then went on to '36 and '40 Ford convertibles. In later years, he went on to working on the classics. He had a collection of 1960-66 T-Bird convertibles, including a beautiful '63 Sport Roadster which was his favorite. From T-Birds, he went on to restore a collection of '65, '66, '67 Lincoln 4-door convertibles and finally, in 1975, got interested in Mustangs. His collection ranges from restored '64¼ to '68 convertibles and fastbacks. As you can see, he has been partial to the Ford line, but really enjoys the beauty of all types of antique and classic cars.

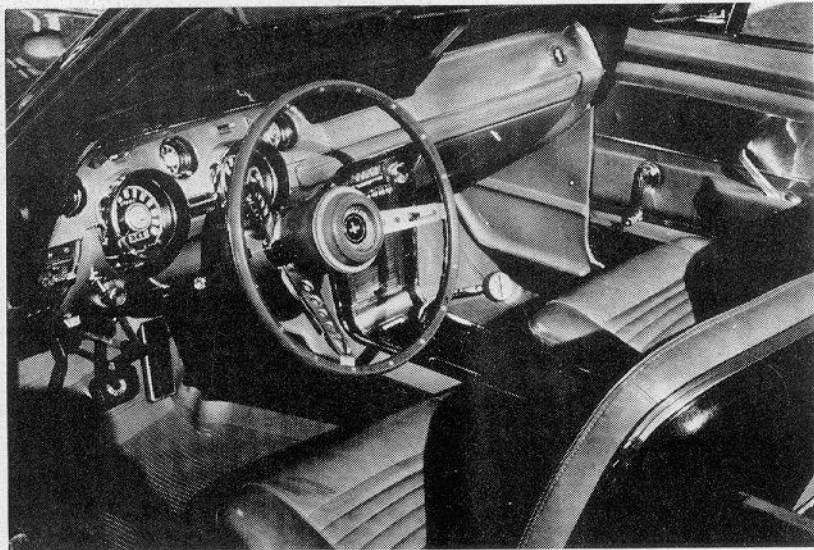

mr. mustang

"Complete" Mustang Parts Store and Frame-Up Restoration Facility.

If you don't see it listed here, call anyway these are just a few examples of our vast inventory.



SHEET METAL
We have all sheet metal available and in stock! Here are some examples:

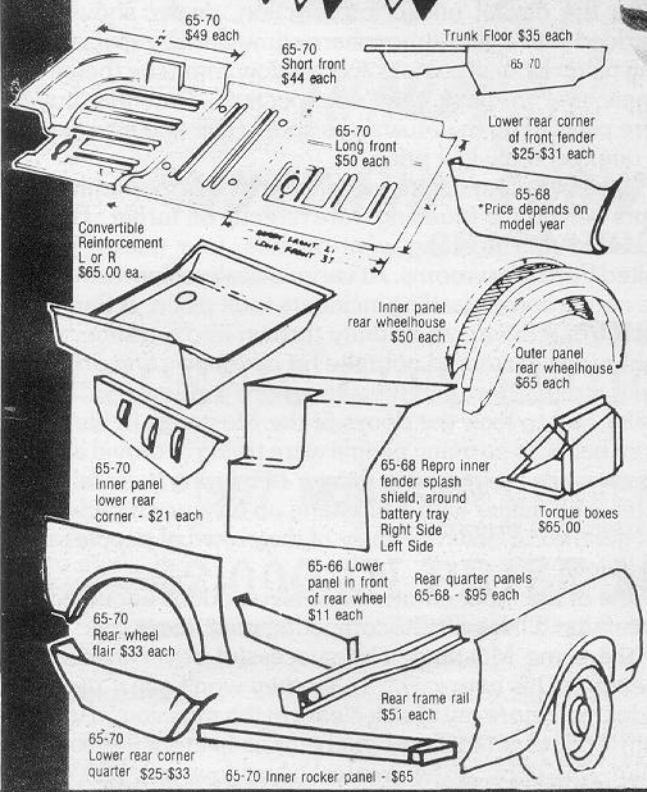

For Toll Free Orders Of \$25.00 or More Call (800) 543-9195 - Ohio Residents Call (513) 275-7439. Send \$2 For Our Current Catalog

- 65/66 Pony Corrals for front grilles available and in stock.
- 65/66 3 Pronged Wheel Spinners with blue centers ... ea. \$25.00
- Set of 4-\$98.00 w/o centers-\$20.00 ea. Centers alone-\$10.00 ea.
- 65/66 Styled Steel Wheel Centers, 2 1/2" complete ... ea. \$13.00
- 65-70 Simulated wire wheel covers NOS ... ea. \$85.00
- 64 1/2/65 Wheel Cover Spinner & Center Cap ... ea. \$25.00
- 67-70 Wheel Cover Centers, complete ... ea. \$20.00
- 67 Styled Steel Wheel Center ... ea. \$10.00
- 65/66 Air Conditioning Bezels (set of 4) ... \$24.95
- 65/66 Convertible Hinge Bracket (rechromed) pr. exchg. \$90.00
- 65-70 Front or Rear Bumper Rechrome ... \$90.00
- 65/66 Right Hand non-remote mirror ... ea. \$75.00
- 65/66/67 GT Light Bars ... \$100-\$125
- 65-68 Luggage Rack ... \$135-\$160
- 65-67 Pony Door Panels - All Colors - State Year & Color ... (plus old panels) pr. \$165.00
- 65-68 Upholstery - Complete set ... \$179-\$199
- Pony - Complete set ... \$239
- 65-70 Molded Carpet (specify year & color) ... set \$100
- 65/66 Door edge guards ... pr. \$24.95
- 65/68 Kick Panels ... pr. \$35.00
- Convertible Top Chrome Trim - Right & Left ... exchg \$75.00
- Repr w/o exchg ... \$75.00

Specify year, body style and trim colors where applicable. All orders shipped UPS. Use your Master Charge, Visa, Check, Money Order or COD.

Mr. Mustang, 5088 Wolf Creek Pike, Dayton, Ohio 45426 (513) 275-7439

Mustang, History of a Love Affair

Part VII of a Series

by
Marc Snyder

The Mustang was to be introduced to the public on April 17, 1964; some three years after the planning of the car began. The long lead time required in the automotive industry, from conception of a car to public introduction day, is a measure of how essential it is to determine the needs of the market several years in advance.

The Mustang's special preview for the press, four days before introduction day, was made against the striking setting of the Ford Pavilion at the New York World's Fair. The press showing proved to be a history-making debut, and reaction was uniformly enthusiastic.

Following the showing of the car, 124 reporters were paired off in Mustangs and given a set of road rally instructions that took them 750 miles to Detroit. The original enthusiasm aroused by the showing in the Ford Pavilion was increased by the driving experience on the highways, and was subsequently expressed in warm terms in the written reports of the correspondents. *Time* and *Newsweek* carried simultaneous cover stories. *Life*, *Look*, *Esquire*, *US News & World Report* and other top-flight publications carried editorial spreads. The press as a whole was unusually generous in praise of the Mustang.

Another history-making "first" took place on the night of April 16. For the first time in TV experience, a major automotive manufacturer presented simultaneous programs on three major television networks. Mustang's image was projected into 29 million homes during prime viewing time.

The next day, Mustang announcement ads ran in more than 2,600 newspapers in approximately 2,200 markets. The ads were, in effect, special invitations to the buyers for whom the car had been created. In newspapers, in women's pages, in 24 of the top nationally-circulated magazines, these invitations were extended to young people, young marrieds, sophisticates, older groups still young at heart, and the millions of families with two or more cars. A marketing program was planned for each of these types of buyers.

To generate mass enthusiasm, it was considered vital to expose the car quickly to as many people as possible. Since the entire public could not come to the car, the car was taken to the public. City dwellers saw Mustangs at more than 70 high-traffic metropolitan locations throughout the United States. Air travelers saw Mustangs in 15 major airport terminals from New York to San Francisco. People on the go on the road saw Mustangs racing toward them from billboards in more than 170 important markets. The suggested retail price was prominently featured on the boards, as it was in all introductory Mustang advertising, in order to position the new car immediately within the automotive market.



To gain further swift exposure, various types of promotional tie-ins were executed. One hundred Holiday Inns displayed Mustangs in their lobbies or near their main entrances. Four top TV shows used Mustangs as prizes on their programs. Many other companies used the car as prizes on their promotional campaigns, adding to the pulling power of their promotions, and simultaneously adding to the car's public exposure.

On the day of public introduction, dealer showrooms sparkled with a gala atmosphere stimulated by special Mustang pictures, wall posters and window trim. The theme was simple and forceful: the "unexpected." Potential buyers were pleased by the Mustang's sporty flair and intrigued by its unexpectedly low price.

There was immediate evidence that the marketing concepts behind the Mustang were directly on target. The first weekend the Mustang went on sale, four million people visited Ford showrooms. At various dealerships throughout the nation some startling incidents took place. A San Francisco truck driver, apparently thrown into a trance by the sight of the car, could not take his eyes away and drove his truck straight through the showroom window. A Chicago dealer had to lock the doors of the Mustangs in his showroom because so many people were trying to crowd into the cars at once they were in danger of injuring themselves. A Pittsburgh dealer with a Mustang up on a wash rack could not get the car down because of the crowd of people pressing below.

One of the most emotional of all reactions occurred at a dealership where fifteen competing customers tried to bid on the same Mustang. The successful buyer insisted on sleeping in his new car, "... so they won't sell it out from under me before my check clears in the morning." And this from a rejuvenated Texas bachelor of 44 in a letter to Ford: "Man, this pony is the greatest. A widow with 7000 acres came 60 miles so I could take her riding in it. I thought the jig was up for me. Thank you, thank you, thank you."

The favorable reaction to Introduction Day carried over and was strongly sustained. Within four months more than

100,000 Mustangs had been sold, and the car had taken its place among the top five automobiles in sales volume. The market that had been looking for a specialized car had found it.

Research of data from "Mustang Guide", by Bill Stone, published by the Benson Printing Co, 1965; and "The Mustang Story" by the Ford Motor Company, Educational Affairs Department, number 5.

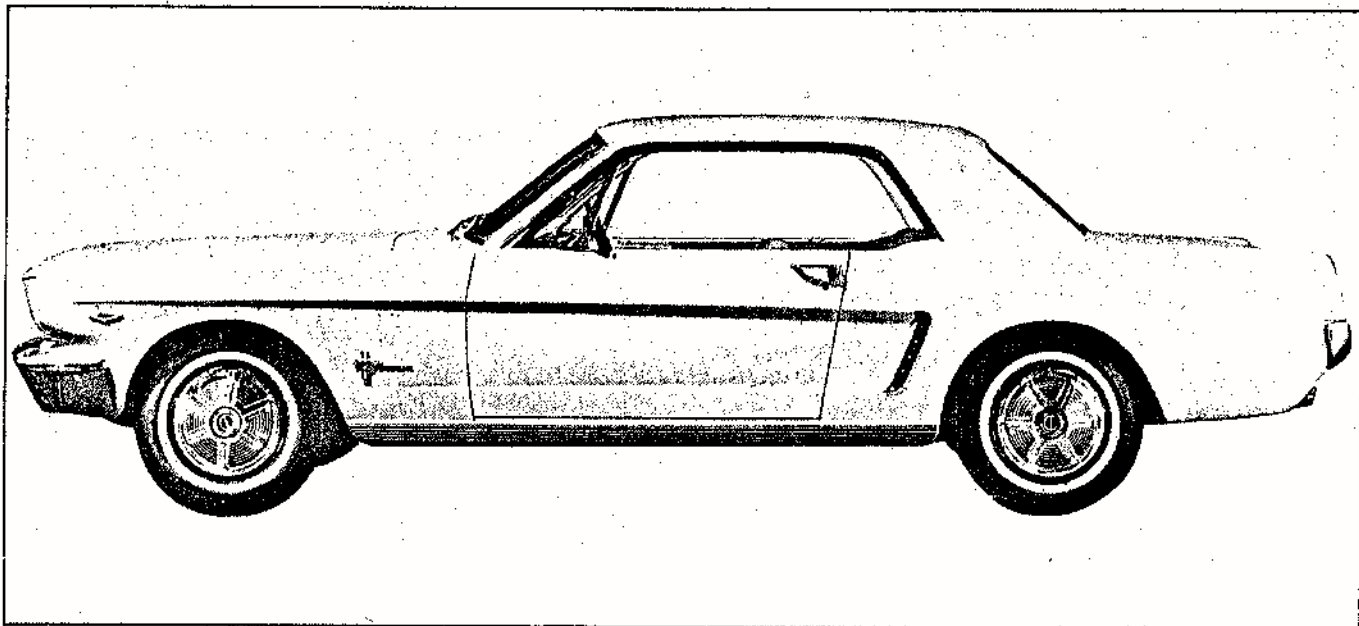

FIRST MUSTANG PRODUCTION MODEL—1964

MAY 27, 28, 29, 1983

INAUGURAL MEMORIAL DAY

MUSTANG SHOW AND SWAP MEET
CHATTANOOGA, TENNESSEE

SPONSORED BY
SCENIC CITY REGIONAL MUSTANG CLUB

1967 MUSTANG CONVERTIBLE TO BE GIVEN AWAY
(Proceeds to Shriners Crippled Children Hospital)

\$2,000 IN PRIZE MONEY TO BE GIVEN

1st Place \$50.00

\$200 each Best Convertible, Coupe, Fastback, Shelby-Boss and Modified

Headquarters:

THE READ HOUSE
827 BROAD
CHATTANOOGA, TN 37402
1-800-251-6443
1-800-572-7304 (TN ONLY)

Show Site:

JAYCEE FAIRGROUNDS
AMNICOLA HWY. 58 S.
CHATTANOOGA, TN

For More Information Contact:

EDDIE CAHEELY
1907 BURMA ROAD
ROSSVILLE, GA. 30741
1-404-866-4587

JOHN HENDERSON
P.O. BOX 911
HEXSON, TN 37343
1-615-875-6991

Mustang Club of America's 1st Indoor Southern National

Hosted by the Mississippi Regional Group, MCA
June 17, 18, and 19, 1983

Show Site: Mississippi Coast Convention Center
(Indoors — Air Conditioning — Security)

Headquarters: Howard Johnson's Motor Lodge on the beach. For room reservations phone *collect* (601) 388-6310 9:00 a.m. 'til 4 p.m. Monday through Friday. Rates are \$32 per night single, \$36 per night double, \$41 per night triple, and \$46 per night quadruple. Be sure to make your reservations before May 27th to receive these low rates.

Friday, June 17th: There will be a hospitality party at Howard Johnson's beginning at 7:30 p.m.

Saturday, June 18th: The awards banquet will be held at Howard Johnson's beginning at 7:30 p.m. (dress is casual). This will be a fantastic "Seafood Jamboree." The price for adults is \$15.85 and the price for children is \$6.10. (Prices include tax and gratuity.) A dance will be held immediately after the banquet.

A Poppy Red 1964½ Mustang Convertible with a 260 V8, 3 speed, and white interior will be given away Saturday, June 18th at 5:00 p.m. Proceeds will be donated to the American Cancer Society. Tickets are \$2.00 each, 3 for \$5.00, 7 for \$10.00 or 75 for \$100. Make check payable to American Cancer Society. *Please send your check, request for tickets, and a stamped self-addressed envelope to:*

American Cancer Society
135 Courthouse Road
Gulfport, MS 39501

For additional information contact Show Chairman Lamar Rhodes at (601) 868-5511.

DEADLINE TO REGISTER CARS JUNE 15, 1983.

Mail payment and registration to: Mike Fitzpatrick
104 Lackland Drive
Biloxi, MS 39532

Entry Form

YOU MUST BE A MEMBER OF THE MUSTANG CLUB OF AMERICA TO ENTER

Name _____ Membership No. _____ Exp. Date _____
 Address _____ City _____ State _____ Zip _____
 Year _____ Body Style _____ Serial No. _____
 Year _____ Body Style _____ Serial No. _____
 Swap Meet Spaces 10 x 20 \$25.00 each space — Number needed _____

<input type="checkbox"/> S	<input type="checkbox"/> M	<input type="checkbox"/> U	<input type="checkbox"/> S	<input type="checkbox"/> S	<input type="checkbox"/> R	\$15.00 per \$ _____
T	O	N	T	R.	E	
<input type="checkbox"/> C	<input type="checkbox"/> I	<input type="checkbox"/> E	<input type="checkbox"/> E	<input type="checkbox"/> D	<input type="checkbox"/> T	\$15.00 per \$ _____
K	F	S	E	I	R	
			T	V	E	
					D	

— Only Mustang, Shelby, Boss & Ford Related Parts —

Awards Banquet

Saturday, June 18, 1983 at 7:30 p.m. Adults \$15.85 ea. _____ \$ _____
 Howard Johnson's Children \$6.10 ea. _____ \$ _____

What classes are you certified to judge? _____

Will you judge? Yes _____ No _____

I agree to abide by all rules and regulations of the Mustang Club of America and understand that I am responsible for my automobile and merchandise and agree to release all liability from Mustang Club of America, the Mississippi Regional Group, Howard Johnson's (and associated personnel) for any damage, injury, lost or stolen merchandise from this event.

Signature _____

Mustang Club of America's Sunsphere Grand National

Hosted by the Volunteer Regional Group, MCA
August 5, 6, and 7, 1983

Show Site: Knoxville Convention Center (located at the 1982 World's Fair site).
(Indoors—Air Conditioning—Security)

Headquarters: Holiday Inn World's Fair. 1-800-328-8000 (to make reservations, use the pre-assigned three letter code **CCS** and correct dates). Rates are \$45 per night double, \$5.00 for each additional person. *Alternate reservations* can be made at Knoxville Hilton (1 block away). 1-800-446-3811. Rates at the Hilton are \$39.00 per night any size room.

Information for tickets to the Sunday Brunch Awards Banquet and other social events will be mailed to you with the confirmation for your registration to the show.

A 1968 MUSTANG FASTBACK WILL BE GIVEN AWAY SUNDAY. TICKETS ARE \$1.00 (Proceeds to charity)

DEADLINE TO REGISTER CARS: "JULY 4, 1983"
NO CAR REGISTRATION ACCEPTED AT THE SHOW!!

Entries will receive free T-shirt
Contest for models and pedal cars will be held.

THIS IS AN INDOOR SHOW AND IT MUST BE UNDERSTOOD THAT NO CARS WILL BE MOVED UNTIL SUNDAY AFTERNOON AT 5 P.M. (Car rentals can easily be arranged.)

FOR ADDITIONAL INFORMATION CONTACT SHOW CHAIRMAN:
ALSO MAIL PAYMENTS AND REGISTRATIONS TO:

Doug Owen
1612 Foxboro Drive
Knoxville, TN 37912
(615) 947-6797 (615) 687-1060

Entry Form

YOU MUST BE A MEMBER OF THE MUSTANG CLUB OF AMERICA TO ENTER

Name _____ Membership No. _____ Exp. Date _____

Address _____ City _____ State _____ Zip _____

Year _____ Body Style _____ Serial No. _____ S M U S S R \$15.00 _____

Year _____ Body Style _____ Serial No. _____ T O N T R E _____

C I E D I R \$15.00 _____
 K F S E E D I R _____
T V E

Swap Meet Spaces 10 x 20 \$100.00 each space — Number needed _____ \$ _____

— Only Mustang, Shelby, Boss & Ford Related Parts —

Raffle tickets for 1968 Fastback at \$1.00 each — Number needed _____ \$ _____

Free T-Shirt - Size _____

What classes are you certified to judge? _____

Will you judge: Yes? _____ No? _____

I agree to abide by all rules and regulations of the Mustang Club of America and understand that I am responsible for my automobile and merchandise. I agree to release all liability from Mustang Club of America, Volunteer Regional Group, Holiday Inn (and associated personnel) for any damage, injury, lost, or stolen merchandise from this event. I also agree to leave my car or vendor space stationary until 5 p.m. Sunday, August 7th.

Signature: _____

WALKER
SUPER STRESSED
 DESIGN
 3 YEAR WARRANTY

NEW PRODUCT

Mustang Hi-Efficiency Radiators 1965-67 V-8's

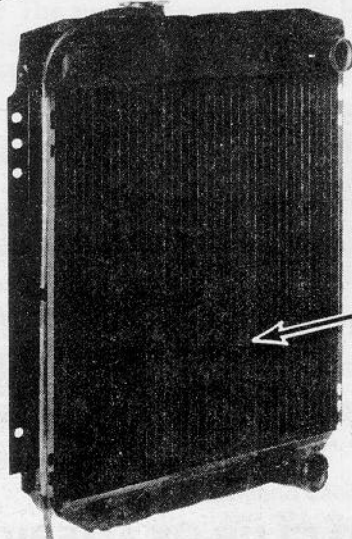

- HEAVY DUTY REPLACEMENT
- RADIATOR BRACKETS ACCEPT FAN SHROUD
- OIL COOLER FOR AUTOMATICS
- ES FIN DESIGN

Model ES602-1/1965-66
 Model ES603-1/1967

For the Ultimate in Cooling
 Ultra Heavy Duty
 S-Line Design Radiators
 for
Mustangs

Designed for Ultra
 Hi-Performance Engines.
 Four Models to Choose From

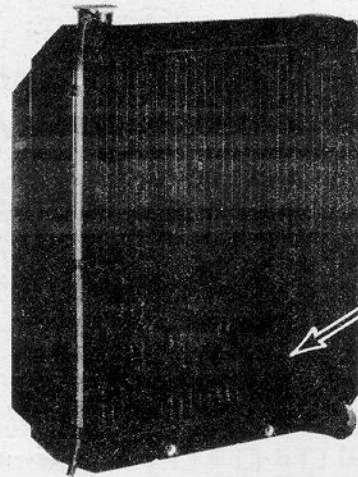

HE
 Fin Design
 A Walker
 Exclusive

- Model HE604-1 1965-66 3" Core
- Model S605-1 1965-66 3 3/4" Core
- Model HE606-1 1967 3" Core
- Model S607-7 1967 3 3/4" Core

Walker
**RADIATOR
 WORKS**



SEE YOUR LOCAL MUSTANG SUPPLIER, OR SEND \$2.50 FOR ILLUSTRATED CATALOG

901-527-4605 694 Marshall Avenue • Memphis, TN 38103

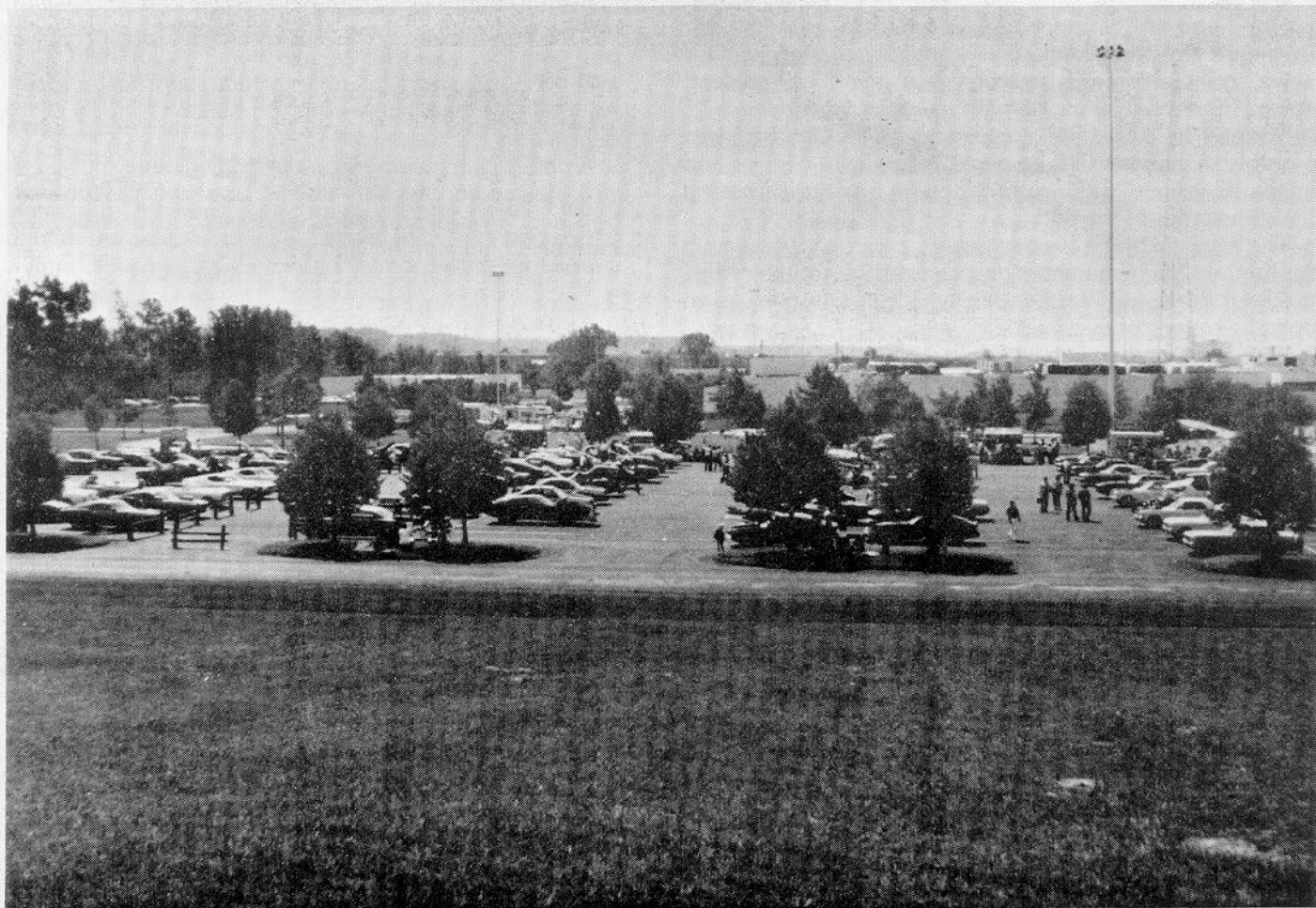

TriState Mustang Club

Shown is our summer show at Scarlet Oaks Vocational. We had great weather both days of our event. Since that time we have had an Autumn Road tour and a Christmas party. We have also entered the Cavalcade of Customs car show in Cincinnati.

William H. Sullivan
National Director

Copperstate Mustang Club

The Copperstate Mustang Club of Phoenix recently held its 1983 officer elections. The results are John D'Ambrosio, President; Forrest Scarpitto, Vice President; Delia Scarpitto, Secretary/Treasurer. The newly appointed members of the Board of Directors are Fred Milici, Larry Sprague, Bob Donaldson, Barry Goss, Ron Rugguero, Gerald Young, and Jerry Young. Linda Donaldson has been appointed to the Arizona Automobile Hobbyist Council.

The tentative events for 1983 include:

- April - Picnic
- May - Cannonball Rally to Prescott for a car show
- June - "Cars for Cures" Car Show for Muscular Dystrophy
- July - Barbeque at Fred Milici's
- August - Swim party at the Ravens
- September - Pancake breakfast
- October - Great Pumpkin Rally in Tucson
- November - Poker Run
- December - Christmas party

The Copperstate Mustang Club had several functions last year including swimming parties, cookouts, picnics, a pancake breakfast and photo session, and parties. The highlight of the year was the CMC sponsored Phoenix's First Great Pumpkin Rally and Show. The function, held October 22, 23, and 24, was co-sponsored by the Southern Arizona Mustang Club of Tucson. We had a wine and chese party, cocktail party, dinner, costume party and Halloween dance, and a brunch and awards ceremony in addition to the show.

Lynn Geyer

REGIONAL GROUP NEWS

Three Rivers Regional Group

Our February 24 meeting was called to order by our President Norb Hodgson with 29 members present. Our new membership cards were given to members present, and all others will be mailed with the next newsletter.

Starting in April and running through October, our monthly meetings will take place in the form of trips and meets. Everyone in the club is looking forward to driving their Mustangs in the outings.

The highlight of the evening was the beginning of our club scrapbook. Many members donated pictures of their Mustangs for the book. We intend to keep the scrapbook as an ongoing history of our club.

Donna Penkova
Secretary

Valley Forge Region

The regular monthly meeting of the Valley Forge Region Mustang Club was held February 3 at the Downingtown Savings & Loan Assoc. in Exton, Pa.

Events chairman Warren Perkins reported that plans for our second annual show at Sloan Motors are well under way, and he would be asking members for help. Other events on the yearly calendar include the Chester County Antique Car Club show at Exton Mall on May 29, a road rally in June, and a parade in July.

A poll of club members on the judging issue showed that 27 votes were cast for judging and two persons were opposed. President Aberts addressed this issue in his monthly column in the club newsletter.

Of special interest to club members was a report by Regional Director Pat Vassallo who informed the club of happenings within the national club which they would be interested in.

Following the business meeting, Joseph Povey from nearby Matthey-Johnson Company gave an outstanding presentation on his company's manufacture of catalytic convertors and their use. Mr. Povey also presented Tracy Perkins with a necklace from the company as a door prize.

Jim Aberts
President

MUSTANG KEY

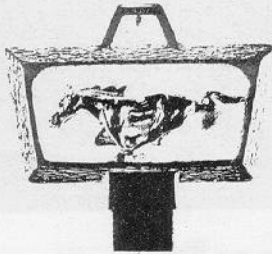

Shown Actual Size

A beautiful lasting gift for the Mustang enthusiast. Uniquely designed, 3-dimensional Mustang ignition key. Artistically hand finished with attention to detail and quality. Your satisfaction guaranteed.

Solid Jeweler's Bronze - \$14.95
Solid Sterling Silver - \$29.95

California Residents add 6½% Sales Tax. Please state year of car. Send Check, Money Order or Visa to:

Unique Jewels

3111 Los Feliz Blvd., #104
Los Angeles, CA. 90039

Catalog \$2.00

Mustang of Chicago™

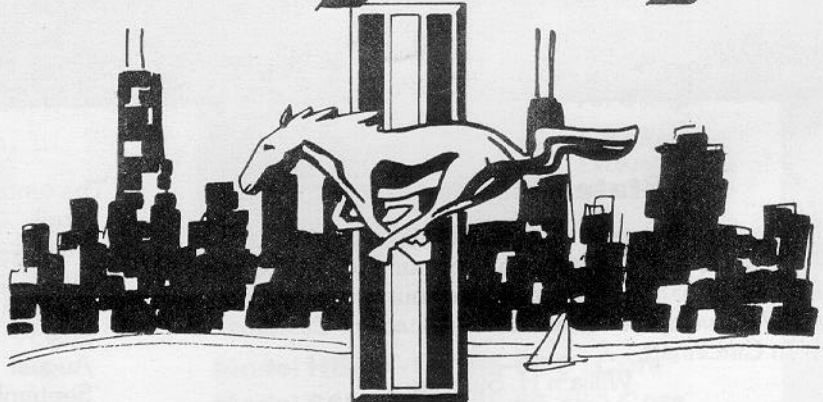

WE CARRY A COMPLETE LINE OF ---

- 65 thru 72 73 Mustang parts
- 65 thru 70 Shelby parts
- 32 thru 56 Ford parts

DIVISION OF

DELUXE FORD PARTS LTD.

227 E. JAMES UNIT #6

BENSENVILLE, IL 60106

(312) 860-7077

Treasure Coast Mustang Club

Our new officers are president, Greg Michaelian; vice-president, Tony Bebout; secretary, Madaline Wygant; treasurer, Grace Whitson; national director, Mike Owen.

On the Board of Directors are Mike Baldwin, Tony Bebout, Don Borgman, Greg Michaelian, Mike Owen, and Donald Whitson.

Among our activities have been various rallies held throughout the year, which have proved to be very popular, and a good showing for the Stuart Junior Women's Club Christmas parade. We participated in the Hensen Beach "God and Country Day" parade February 26. The Treasure Coast Mustang Club was in charge of the Mustang Division of the Stuart Sports Car Club show March 27 at Memorial Park in Stuart.

Madaline Wygant
Secretary

Shenandoah Valley Mustang Club

We have about twenty five members who renewed their

membership for this year. A meeting was held at the Rescue Squad headquarters February 27. Refreshments were served by Hilda Belford and Debbie Foltz. Our guest speaker was Larry Wilson who spoke on the history of the Ford Motor Company, particularly the engines from the 1950's to the present; engine sizes, specs, etc. There was also a business meeting to discuss the giving of an outstanding trophy to the winner of the Mustang Class at the Shenandoah Region AACA Car Show to be held at the War Memorial Park on Saturday, May 7. Officers and Committee Chairpersons for the Year 1983 are President, Leonard Foltz; Vice President, Kirby Place; Secretary-Treasurer, Jim Biddle; Assistant to the Secretary-Treasurer, Debbie Foltz; Public Relations, J.C. Black; Club Scrapbook, Dennis Crawford; Show Chairman, Rick Combs; Assistant to the Show Chairman, Bob Belford; Registration Chairman, Sharon Miller; Social Committee, Debbie Foltz and Hilda Belford; Technical Advisory Committee, Red Shade, Earl Estep and Preston Whitacre.

Jim Biddle
Secretary-Treasurer

AT LAST...



1965/1966 Mustang Low Profile V8 Rally Pacs!

Yes, finally a faithful reproduction of the original Rally Pac for all 1965 & 1966 Mustangs with the 5-gauge instrument panel.

We have all experienced or heard from a friend about paying up to \$300 for a used Rally Pac that "worked when they took it out of the car" but doesn't work now that you spent your hard earned money on it. Or perhaps you bought an incomplete Rally Pac that needs some obsolete part, that all of a sudden turned your good deal into an albatross.

While we can't sell you any repair parts, we can tell you if you had one of our new units they have a full warranty for workmanship, materials, and components. No messing around when it comes to installation either. These come complete with wiring harness (set up for original plug in), includes clamp, wire guide cover, instructions, and is painted the wrinkle finish color you need to match your interior. Then all you need is a screwdriver and to make a few simple plug in connections and you can start enjoying one of Mustang's most popular options!

ORDER FROM: **VINTAGE MOTORS, INCORPORATED**
P.O. Box 2224, Des Moines, Iowa 50310
(515) 274-4540

ONLY
\$259⁹⁵
6,000 R.P.M. V8 & 6 CYL.
\$279⁹⁵
8,000 R.P.M. V8
(Add \$10 for colors other than black wrinkle finish)

(No Dealer
Inquiries Please)

We accept Mastercard & Visa.
Or send money order, etc.
(Please allow 3-4 weeks
for delivery).
Be sure to specify
color desired.

REGIONAL GROUP NEWS

Birmingham Mustang Club

At our January meeting it was nice to have Joe George, our president, back with us once again.

B.M.C. participated in the annual World of Wheels again this year. For the last 3 years, B.M.C. has helped get the show started and closed. The money earned goes to our treasury for club expenses during the year. B.M.C. would like to thank the dedicated members who worked (believe me it is hard work!) to help earn \$1,650.00 for our club's treasury.

In our own display we had a real wagon with two cowboys seated on top holding reins that ran to six ponies side by side. The cars shone and gleamed, waited for the public to view them, as their proud owners manned our display. Out of six cars entered, five won trophies. One member entered on his own and won.

Our display won third place; we received a plaque and \$50. It took a lot of work and dedication to do this again this year, and to our members who helped B.M.C., thanks to you all. B.M.C. is planning a show at Shermon Holland Ford around April 16 to display our ponies and have a great time as we always do there. Congratulations to World of Wheels

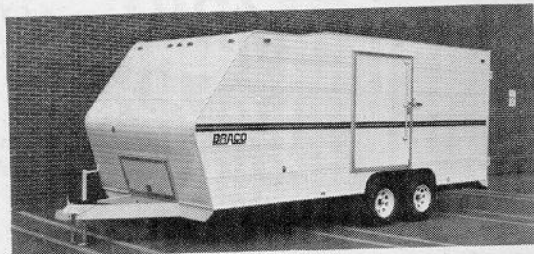

Mustang Car Trailers

OUTSTANDING FEATURES INCLUDE:

1. Aerodynamic design for easy towing and less wind resistance.
2. Slide-in, self-storing ramps
3. White spoke wheels
4. Complimentary accent stripes (we can match motor homes)
5. Insulated and paneled interior
6. 24" Curbside door, plus much, much more.

★ **MANY SIZES AVAILABLE
WITH CUSTOM OPTIONS** ★

Jim Osborn's
2627 Stone Drive
Lilburn, GA 30247
(404) 498-0644



SPOIL YOURSELF!

We now have the rear wing spoilers that were originally optional equipment on all '69-73 SportsRoof models. When mounted, these are identical to the Ford unit; the only difference is the pedestals - the Ford pieces are hollow, ours are solid, unnoticeable with the spoiler on the car. Call for prices, specifying 1969-70 or 1971-73 **\$149.95**

Free Shipping to MCA Members



AUTO KRAFTERS

FT. CALHOUN, NEBRASKA 68023
Toll Free Outside Nebraska 1-800-228-7346, or 402-426-9851

winners: Donna Rodgers, 1967 coupe, first; Wayne Wells, 1965 conv., first; David Smith, 1965 coupe, second; Preston Fussell, 1968 conv., second; John Aldridge, 1968 conv., third; Mike Tankersley, mod. first, single entry.

Elaine Dodson

Scenic City Regional Group

Officers for 1983 are Jolm Henderson, President; Eddie Caheely, Vice-President; Patsy Downer, Secretary/Treasurer

Our fourth Invitational Mustang Show at Mr. View Ford was held March 25-26.

The club purchased a 1967 Mustang Convertible to be given away at the EXPO, May 27-28. The progress on refinishing the car is going very good. Tickets are now available at \$1.00 each.

Our meetings are on the first Tuesday night of each month at 7:30 at the Country House Restaurant on Dayton Blvd. in Chattanooga. We would like to invite anyone interested to join us at these meetings or at any of our events.

Patsy Downer
Secretary/Treasurer



Hoosier Mustang Club

The Hoosier Mustang Club met February 9 at the Ponderosa Steak House, with a total of 22 members present. Our new point system for the year was set up. The member at the end of the year with the most points wins his membership dues for the following year. Points are earned through attending meetings, chairing committees and attending club activities. After a very mild winter of no measurable snow, the first drive for the year is the Cobweb tour, April 17, weather permitting. Mr. and Mrs. Robert Kirby and Mr. and Mrs. William Trimpe are hosts for the event. The last drive of 1982 was the Columbus Day Parade in October with 23 Mustangs lining Washington Street in the beautiful sunshine. Someone up there knew those ponies wanted one last romp before being put into storage for the winter.

Sharon Hembree
Secretary

Hoosier Columbus Day Parade

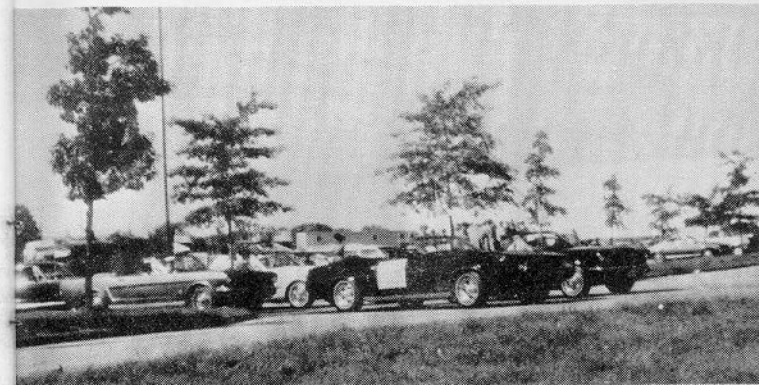
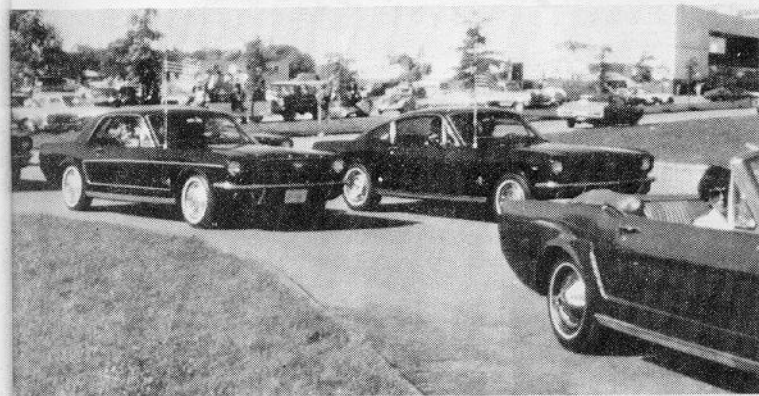

REGIONAL GROUP NEWS

First State Mustang Club

At the March meeting of The First State Mustang Club of Delaware, we were very pleased to have as guest speakers Mr. Pat Vassallo and Mr. Lindy Sindoni from Mid Country Mustang, Inc. They gave a very informative presentation on valuing your Mustang. After the presentation and slides, the floor was opened for questions. Everyone seemed very interested in knowing just how much different options on their cars increased the value. Since the meeting was held at

the home of one of our members who had restoration done by Mid Country Mustang, we could see first hand the work they performed.

We would like to thank Mr. Vassallo and Mr. Sindoni for taking the time to come to our meeting and speaking with us, especially on such a miserable evening. We also want to thank Mr. Vassallo, who is national director for the Valley Forge Regional group, for giving us the encouragement we needed for the growth of our new club.

“MUSTANG MAGIC” In Montgomery, Part II

A fledgling club less than six months old, The Heart of Dixie Mustang Club of Montgomery, Alabama delivered some real Mustang Magic at their first Mustang Show at Courtesy Ford. Best of Show trophy went to Harrell McKinney's 1964½ white convertible. Getting a lot of attention was Carl Hubbard's '68 Shelby GT 500KR convertible and Jerry Willoughby's candyapple red 1966 convertible. Among other beauties were Bob Messick's 1966 candyapple GT and Harrell's white '64½ hardtop. Photos courtesy of Gary Stein.



Best of Show: Harrell McKinney's white 1964½ convertible.

**Carl Hubbard's
1968
GT500KR**



Captivating Candyapples

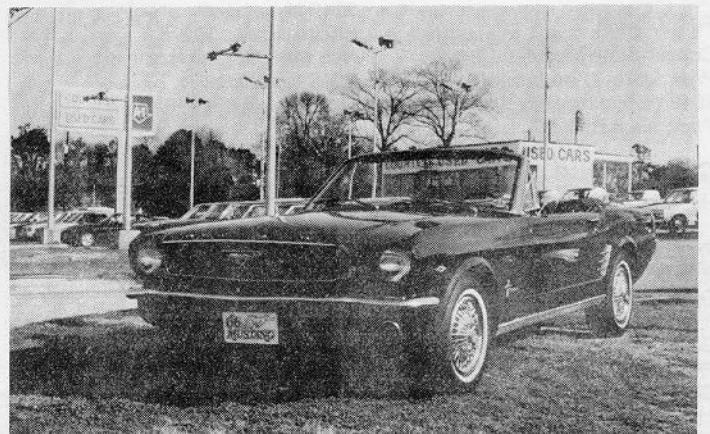
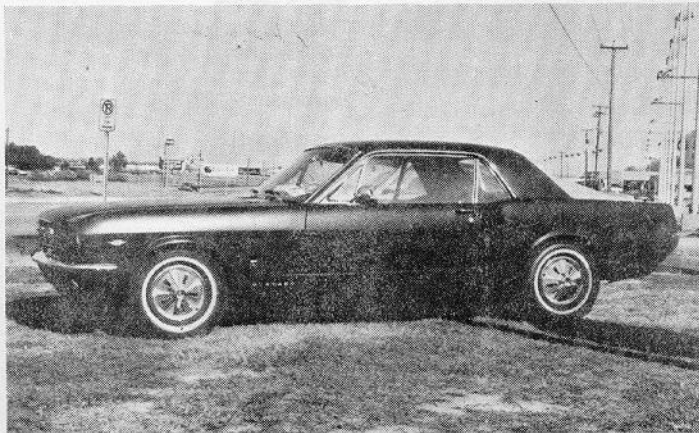

REGIONAL GROUPS

ALABAMA

Birmingham Mustang Club
Pres.: Joe George
3544 Fox Hollow Lane
Birmingham, AL 35226
Nat. Dir.: Randy Burdine
8953 Valley Hill Dr.
Birmingham, AL 35206

Heart of Dixie
Mustang Club
Pres.: Jerry B. Lowery
4691 Summit Dr.
Millbrook, AL 36054
Nat. Dir.: Harrel McKinney
535 South Hull St.
Montgomery, AL 36103

Model City Mustang Club
of Anniston
Pres.: David Spellman
5804 Medders St.
Anniston, AL 36201
Nat. Dir.: Bill Ingram
3313 Hwy. 21, S.
Oxford, AL 36203

Rocket City Mustang Club
Nat. Dir.: Vernon Bush
2116 Southpark Blvd.
Huntsville, AL 35803

Shoals Mustang Club
Pres.: Olen Bishop
P.O. Box 203
Cherokee, AL 35616

Wiregrass Regional Group
Pres.: Roger Adkinson
1603 N. Cherokee St.
Dothan, AL 36301

ARIZONA

Copper State Mustang Club
Pres.: John D'Ambrosio
2049 W. McRae Way
Phoenix, AZ 85027

CALIFORNIA

Highway Horsemen
Southern California
Pres.: Steve Bilderain
P.O. Box 877
Ontario, CA 91761

Golden Hills Mustang Club
Pres.: Gil Baumgartner
Gil's Ford Center
1128 Western St. #28
Fairfield, CA 94533

DELAWARE

The First State Mustang Club
Pres.: Dick Steininger
19 W. Bender Dr.
Newark, DE 19711
Nat. Dir.: Jill Smethers
16 Duquesne Ct.
New Castle, DE 19720

FLORIDA

Treasure Coast Mustang Club
Pres.: Greg Michaelian
762 S.W. Falcon St.
Palm City, FL 33490
Nat. Dir.: Mike Owen
3800 S.W. St. Lucie Shores Dr.
Palm City, FL 33490

Gulf Coast Regional Group
Pres.: Paul McClain
P.O. Box 10126
Pensacola, FL 32504
Nat. Dir.: David Walters
8570 Acapulco Camino
Pensacola, FL 32507

Hernando County Mustang Assn.
Pres.: Tony Lagone
P.O. Box 282
Brooksville, FL 33512

Central Florida Regional
Mustang Club
Co-Pres.: R. W. Simmons
Henry Howard, Jr.
Nat. Dir.: Ken Daniel
P.O. Box 2426
Orlando, FL 32802

GEORGIA

Chattahoochee Valley Region
Mustang Club
Pres.: Virgil Frank Petty
5609 Fairchild Dr.
Columbus, GA 31904

Georgia Regional Group
Pres.: Mel Parks
2249 Myra Lane
Snellville, Ga. 30278
Nat. Dir.: Gordon Harrison
2915 Greenrock Tr.
Doraville, GA 30340

West Georgia Regional
Mustang Club
Pres.: Larry E. Fincher
Rt. 2, Grayson's Landing
Hogansville, GA 30230

HAWAII

Aloha Mustang & Shelby Club
of Hawaii
Pres.: Ray Phillips
Nat. Dir.: Don Traver
P.O. Box 6216
Honolulu, HI 96818

ILLINOIS

Central Illinois Regional Chapter
Pres.: Floyd Scranton
61 Ronald Dr.
Decatur, IL 62526
Nat. Dir.: Joe Hengst
1010 West North Street
Decatur, IL 62522

Mid-America Regional Group
Pres.: Monty Shehorn
120 Smith Ave.
Flora, IL 62839
Nat. Dir.: Same as above

Southern Illinois Mustang
Association
Pres.: William J. Lauck
3400 Agnes Blvd.
Alton, IL 62002
Nat. Dir.: Kenneth C. Stange
629 N. 38th St.
Belleville, IL 62223

INDIANA

Hoosier Mustang Club
Pres.: Elmer Trimpe
P. O. Box 2065
Columbus, Indiana 47202-2065
Address above

Old Fort Mustangers
Pres.: Ron Miller
18723 Amstutz Rd.
Auburn, Ind. 46706
Nat. Dir.: Noah Yoder
Rt. 1, Buckskin Rd.
Hicksville, OH 43526

Pony Express River City Mustangs
Pres.: Randy Adams
1003 Corregidor
Evansville, IN 47714
Nat. Dir.: Scott Seitz
601 Locust St.
Mt. Vernon, IN 47620

KANSAS

Kansas City Mustang Club
Pres.: Ernie Pyle
11807 W. 55th St.
Shawnee, KS 66203
Nat. Dir.: Kert Maul

KENTUCKY

Bluegrass Mustang Club,
Central Kentucky
Pres.: Jerry Caton
P.O. Box 11803
Lexington, KY 40578
Nat. Dir.: Same as above

LOUISIANA

Ark-La-Tex Pony Express
Pres.: Randal J. Landry
627 Gladstone Blvd.
Shreveport, LA 71104

The Baton Rouge Mustangers
Pres.: Billy De Witt
Route 3, Box 662-L
Denham Springs, LA 70726

MARYLAND

Mustang Club of Maryland
Pres.: Gene Schwandtner
P.O. Box 23
Bel Air, MD 21014
Nat. Dir.: Same as above

MICHIGAN

Michiana Mustangs
Pres.: Bob Kasprzak
19629 Old Ridge Rd.
South Bend, IN 46614
Nat. Dir.: Same as above

Mustang Owners Club of
Southeastern Michigan
Pres.: Mark Bednarek
P.O. Box 39088
Redford, MI 48239
Nat. Dir.: Don Gillespie
33070 Rosslyn
Garden City, MI 48135

MISSISSIPPI

Mississippi Coast Stangers
Pres.: Lamar Rhodes
% Specialty Cars, Inc.
1914 28th St.
Gulfport, MS 39501
Nat. Dir.: Jack Wilbanks
127 Vista Dr.
Pass Christian, MS 39571

MISSOURI

Mid-Missouri Mustangs
Pres.: Fred Nothstine
2701 Essex St.
St. Charles, MO 63301
Nat. Dir.: Tom Hoyt

MONTANA

Treasure State Mustang Club
Nat. Dir.: Kevin McAtee
Box #3, 810 N. 7th
Bozeman, MT 59715

NEBRASKA

Mustang Car Club of Omaha, Inc.
Pres.: Ronald D. Miller
P.O. Box 141
Ft. Calhoun, NE 68023
Nat. Dir.: David Spry
9827 Larimore Ave.
Omaha, NE 68134

Northeast Nebraska Mustang Club
Pres.: Rich Borer
Box 214
Madison, NE 68748

NEVADA

Mustang Club of Las Vegas
Pres.: Phil Smitley
2485 Marlene Way
Henderson, NV 89015

NEW JERSEY

Central Jersey Mustangs
Pres.: Kurt B. Kilichowski
93 Robin Drive
Mercerville, NJ 08619
Nat. Dir.: Same as above

The North Jersey
Mustang Club, Inc.
Pres.: George Mansey
Nat. Dir.: John K. Griffith, Jr.
P.O. Box 212
Northvale, NJ 07647

South Jersey Mustangs
Pres.: Rich Riley
682 North Mill Road
Vineland, NJ 08360

NEW MEXICO

Rio Grande Mustang Club
Pres.: Bob Miller
Nat. Dir.: Bob Underwood
9716 Trumbull SE
Albuquerque, NM 87123

NEW YORK

Mustang of Buffalo
Pres.: Ray Keim
P.O. Box 272
N. Tonawanda, NY 14120
Nat. Dir.: Bill Lewis

NORTH CAROLINA

Carolina Region Mustang Club
Pres.: Jack Setzer
511 Beverly Dr.
Gastonia, NC 28052
Nat. Dir.: Perry Rivers
Route 1, Box 421 Lot #17
Harrisburg, NC 28075

Eastern North Carolina
Regional Group
Nat. Dir.: Richard Pittman
1612 Lakepark Dr.
Raleigh, NC 27612

First Piedmont Regional Group
Pres.: Marion J. Hall
Rt. 1, Box 240
Lawsonville, NC 27022
Nat. Dir.: Harold D. Goad
Rt. 2, Glenwood Ter.
Stuart, VA 24171

Sandhills Regional Group
Pres.: Ray Craig
418 N. Wright St.
Raeford, NC 28376
Nat. Dir.: Mac McBryde
Rt. 1
Aberdeen, NC 28315

Gate City Triad Club
Pres.: Loy Williams
1603 Clement Ct.
Greensboro, NC 27410
Nat. Dir.: Bobby Dodd
201 Kirkland Dr.
Danville, VA 24541

OHIO

Hall of Fame Mustangers
Nat. Dir.: John Hembree
2404 Clarendon Ave, NW
Canton, Ohio 44708

Northeastern Ohio Regional Group
Pres.: Dennis Bujak
9067 State Rt. 44
Revenna, OH 44266
Nat. Dir.: Bob Myers
P.O. Box 45203
Westlake, OH 44145

Northwest Ohio Regional Group
Pres.: Hugh B. Black
P.O. Box 86
Bucyrus, OH 44820
Nat. Dir.: Larry Graser
786 Sandalwood Road W.
Perrysburg, OH 43551

Tri State Mustang
Pres.: Terrence Rotert
3415 Oakmeadow Ln.
Cincinnati, OH 45239
Nat. Dir.: Bill Sullivan
P. O. Box 41538
Cincinnati, Ohio 45241

OKLAHOMA

Mid-West Mustang Club
Pres.: Bob Miller
P.O. Box 112
Lamont, OK 74643
Nat. Dir.: Same as above

PENNSYLVANIA

First Pennsylvania Regional Group
Pres.: Bill Bollman
65 N. Walnut St.
Macungie, PA 18062
Nat. Dir.: Fred Glazier, Jr.
531 Wambold Rd.
Souderton, PA 18964

Centre Region Mustang Club
Pres.: David Runkle
RD #5, Box 43
Bellefonte, PA 16823
Nat. Dir.: Tony Branda
1434 E. Pleasant Valley Blvd.
Altoona, PA 16602

Northeast Pennsylvania

Regional Group
Pres.: Dave Evans
Pad 8, Echo Valley Park
Rt. 7, Shavertown, PA 18708
Nat. Dir.: Arthur Dice
P.O. Box 51
Rock Glen, PA 18246

Three Rivers Regional Group

Pres.: Norb Hodgson
14 Rose Mary Ln.
Library, PA 15129
Nat. Dir.: Frank Stitt
244 Connecting Rd.
Mt. Lebanon, PA 15221

Valley Forge Mustang Club

Pres.: Jim Aberts
1407 Whitford Rd.
West Chester, PA 19380
Nat. Dir.: Pat Vassallo
%Mid-County Mustang, Inc.
891 E. Lincoln Highway
Exton, PA 19341

SOUTH CAROLINA

Central South Carolina
Regional Group
Pres.: Gary Byrd
P.O. Box 2614
Columbia, SC 29202
Nat. Dir.: Craig Zion

Foothills Regional Group

Pres.: Bernard Price
101 Eastover Dr.
Nat. Dir.: Jim Payne
Rt. 1, P.O. Box 93
Piedmont, SC 29673

TENNESSEE

First Tennessee Regional Group
Pres.: Bill Henderson
Kenner Addition
Rogersville, TN 37857
Nat. Dir.: Gary Childress
5120 Woods Way
Kingsport, TN 37664

Lakeway Mustang Club

Pres.: Charles Cross
City 5 - Fulton Rd.
Morristown, TN 37814
Nat. Dir.: Lonnie Hogan
Rt. 5, Box 355
Morristown, TN 37814

Music City Regional Group

Pres.: C. M. Gately
200 Green Harbor Rd.
Old Hickory, TN 37138
Nat. Dir.: Bob Overbey
113 In-A-Vale Dr.
Brentwood, TN 37027

Mustangs of Memphis

Pres.: Ed Xiques
4883 Marianne Lane
Memphis, TN 38117
Nat. Dir.: G. W. McNutt
1857 Rugby
Memphis, TN 38127

Scenic City Regional Group

Pres.: John Henderson
5661 Grayshore Ln.
Hixson, TN 37343
Nat. Dir.: Eddie Caheely
4716 Rossville Blvd.
Chattanooga, TN 37407

Volunteer Regional Group

Pres.: Doug Owen
1612 Foxboro Dr.
Knoxville, Tn 37921
Nat. Dir.: Same as above

TEXAS

North Texas Mustang Club
Nat. Dir.: Ron Clements
4313 Pleasant Run Rd. #155
Irving, TX 75062
Texas Panhandle Mustang Club
Pres.: Milfred Davis
3310 Oxbow
Amarillo, TX 79106
Nat. Dir.: Mike Lewis
Rt. 4, Box 426
Amarillo, TX 79119

VIRGINIA

Old Dominion Mustang Club
Pres.: Alvin J. Landes
Rt. 2
Bridgewater, VA 22812
Nat. Dir.: Robert Halterman
P.O. Box 193
Broadway, VA 22815

Mustelby Mustang Club
Pres.: Richard E. Graham
P. O. Box 12294
Roanoke, Va. 24024
Nat. Dir.: Jeff Robertson
Address above

Shenandoah Valley Mustang Club
Pres.: Terry Zimmerman
423 Fairmont Ave.
Winchester, VA 22601

WISCONSIN

Wisconsin Early Mustangers
Pres.: Dick Doria
2511 W. Carrington Ave.
Oak Creek, WI 53154
Nat. Dir.: Wayne Witte
Rt. 4
Watertown, WI 53094

CANADA

Alberta Mustangs
Pres.: Art E. Scheeler
1840-40th St. SE
Calgary, Alberta
Canada T2B1B4

CLASSIFIEDS

Classified advertising is free to Mustang Club of America members. Each member is limited to one thirty (30) word ad per month. Ads to be repeated must be resubmitted each month. Please type all ads submitted if possible. If not, please print ad copy clearly. *Mustang Times* will not be responsible for the correction of illegible ad copy. Please note that commercial advertising is no longer allowed in the classifieds. All ads must relate to Mustangs, Bosses, and Shels only.

Correspondence concerning classified advertising should be directed to *Mustang Times*, P.O. Box 447, Lithonia, GA 30058.

CARS FOR SALE

1964½ MUSTANG coupe, all orig., EC, rare 260, orig. rally-pac. Make an offer. Roger Crampton, 106 Harwood Place, Enterprise, AL 36330.

1965 MUSTANG conv. 6 cyl., 3 spd., red w/black top, \$3,400. (205) 238-1295, 237-3600

1965 MUSTANG fastback. 289-4bbl., 4 spd. New silver blue paint, new blue int. Completely orig. \$4,100 OBO. Skip Youngdahl, P. O. Box 3193, Incline Village, NV 89450 (702) 831-3197.

1965 MUSTANG coupe, V8, auto, PS, PB, bench seat, ex. int., little rust on ext. Burlington, WI (414) 763-6616.

1965 MUSTANG conv. Rebuilt 289, auto., all new black int., all white ext. \$8,500 or trade for authentic 65/66 GT of show quality. Buster Gordon, Evansville, IN (812) 476-8820.

1966 MUSTANG K-GT conv. Yellow. Black std. int. Very complete car. All numbers match. Has repairable rust, structurally sound. \$4,800 or \$6,000 with extra rust free '66 conv. basket case. Trade toward another K conv. (415) 349-7244.

1966 MUSTANG conv., auto., console, 289, PS, PB, pony int., new white top. ALL redone. New orig. floors, all metal, no rust. EC \$6,500. F.L. Moore. KY (606) 278-9484.

1965 MUSTANG fastback, 4 spd. disc's, AC V 8-rare turquoise color, black int. (214) 597-1481, 561-1243.

1965 MUSTANG hardtop, 289, 3 speed, PS, PB: good condition, price \$1,200. Contact Jack Sutton (304) 754-3270.

1966 MUSTANG conv. (Sprint edition model) 200 6 cyl. auto., PS, PB, console. Restored to MINT cond. Dark blue w/two-tone blue int. 200 miles since restoration. Many new parts. Asking \$9,800. John K. Griffith, 308 Washington Ave. Nutley, NJ 07110 (201) 667-1474.

1966 MUSTANG conv. 289 auto, candyapple red w/white PT. Black pony int. Under 6000 mi. on complete restoration. \$9,500, servious inquiries only. Orville Brown Higginville, MO 64037 (816) 584-3187.

1966 MUSTANG, conv. 289, auto., white PT, aqua body. Pony wood grain int. California MUSTANG light on grill, factory lights on warning signal. Wire hub cabs. EC overall. Asking \$4,800. (513) 868-0647.

1967 MUSTANG conv., restored, white w/red int., 6 cyl., auto., PS, PT, \$7,500. (205) 238-1295, 237-3600.

1967 MUSTANG GT, 289, 4bbl./4 spd., discs, deluxe int., totally rebuilt, orig. window sticker. Doug (308) 284-2720.

1970 BOSS 302, shaker, front, rear spoilers, light blue ext., black int., louvers, VGC, org. BOSS wheels. VA local car. \$6,300. (804) 846-2063.

1970 MACH 1 orig. owner, shaker, 4-bbl 351, PS, PB, auto, ac, stereo AM/FM/cassette, new shocks, mufflers, Firestone radials. Rear spoiler, like new except minor nicks, chrome and paint. Best offer. S. Schaeffer, 7306 Ferguson Rd., Dallas, Tx. 75228. (214) 321-3414.

1972 MUSTANG conv. 351-C 4 bbl., factory AC, PS, PB, tilt, PT, red w/new white top. \$4,400. (205) 238-1295, 237-3600.

CARS WANTED

WANTED: 68/69 SHELBY GT 500 fastback, auto, or 69 GT 350 conv., auto. Must be authentic and have solid body. Donald Marsh, R.D. 1 Box 87A, Nicktown, PA. 15762 (814) 749-9008.

PARTS FOR SALE

MUSTANGERS! See us first at Carlisle swap meet. Space B-86, next to building Y. Complete line-new-used-reproduction parts, bought-sold-traded. Specials on new bumpers, upholstery, more. Mike Hufnagle, RD #3, Box 347, New Oxford, PA 17350.

MUSTANG conv. tack strip ½" x ¾", ⅝" x ⅞", 95¢ a foot. (Plus 15% handling and shipping.)

2 + 2 doors, 64½ - 68, used \$125.00, fold down rear seats \$100, used, send us your needs. Mur-O-Lite P.O. Box 126 Forsyth GA 31029.

289 MUSTANG Hi-Po heads, complete, glass beaded, \$200 for the set. Pete Zovaih 7615 Harpers Glen, Houston, TX 77072 (713) 933-3689.

1966 MUSTANG GT — Virtually everything needed for a dealer option GT. Complete light bar assembly, grille braces, rear valance with rings, exhaust trumpets, fender badges, MUSTANG letter sets, 995 cap, \$395. 1967 SS, complete, \$450 + shipping. All above are EC, correctly reconditioned, ready for installation. R. Freas, 929 Southern, Kalamazoo, MI 49001

Parting Out '67 MUSTANG, two-tone blue int., 69-73 consoles, mag style hubs, 68 GT styled wheels; wanted - 67 conv., 68 2 x 2 options - Colon, 855 E. 233rd, Apt. G, Bronx, NY 10466

Glazier's

MUSTANG BARN, INC.



1966-1970 MUSTANG RESTORATION PARTS CATALOG
1963 WINTER EDITION

GLAZIER'S MUSTANG BARN, INC.
531 Wambold Rd., Souderton, PA 18964
(800) 523-6708 (215) 723-9674
Cont. USA (exc. PA) All other locations
Open 9:00-5:00 Mon-Fri; 9:00-4:00 Sat.
FREE CATALOG: 1965-70 Mustang Parts

NEW PARTS	LITERATURE
USED PARTS	ACCESSORIES
SERVICE	SHEET METAL
VISA	FORD PARTS
MASTERCARD	UPHOLSTERY
COD	CARPET
QUANTITY DISCOUNT	MECHANICAL PARTS

Glazier's

MUSTANG BARN, INC.



• PERFORMANCE PARTS / BUY, SELL and TRADE
• MUSTANGS PARTS

Snakeman

Enterprises

Havard Still
Contact "Snakeman"

615/479-7314 • RT. 9 BOX 588 • CLEVELAND, TENNESSEE 37311



Over 300 Parts Cars We have 1,000s of new parts in stock. Send for free brochure.

RECHROMED PLASTIC

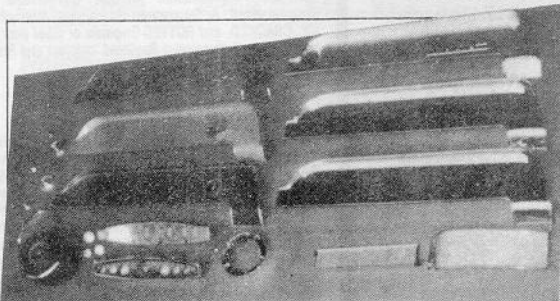

	Retail		Retail
1965-66 Armrest	\$7.50	1967-68 Right dash panel	20.00
1965-66 Air registers	ea. 3.00	1967-68 Right dash panel, painted	30.00
	4 for 12.00	1967-68 Right lower panel	7.50
1965 Dash dial	2.00	1967-68 Right lower panel, painted	12.50
1965 Rally-Pac emblem plate	4.00	1967-68 Center dash panel	6.00
1966 Rally-Pac dial	1.00	1967-68 Center dash panel, painted	11.00
1966 Rally-Pac ring	4.00		
1967 Dash dial (large)	2.00	1967 Horn ring	7.50
(small)	1.00	1968 Horn panel	7.50
1967 Dome light bezel	5.00	1968 Horn panel button	ea 1.00
1965-68 Dash bezel	20.00		
1967-68 Right dash panel	30.00		

NOTE: Do not use tape on these parts. Need to make template or brush paint. Tape pulls off chrome.

ALL RECHROMED PARTS ARE EXCHANGE

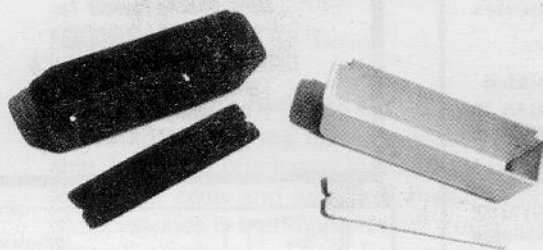

Are your door panel cups peeling or lost? We make new cups and inserts. Cups ea. \$4.50
 Insert ea. \$3.50
 We make the bracket to hold the cup to door pr. \$7.50
 1965 Grille brackets ea. \$3.00
 1965-66 Radiator shroud brackets (for 4 core desert cooler) ea. \$2.75
 Exhaust manifold bolt locks set \$19.95

5613 Elliott Reeder Road
 Ft. Worth, Texas 76117-6091
 Toll Free Ordering
 Outside Texas: 800-433-7850
 Inside Texas: 800-772-7471

New 1966 Woodgrain Kits
 New 1967 Brushed Aluminum Kits
 New 1968 Woodgrain Kits
 Interior Dyes & Paints To Match Original Colors

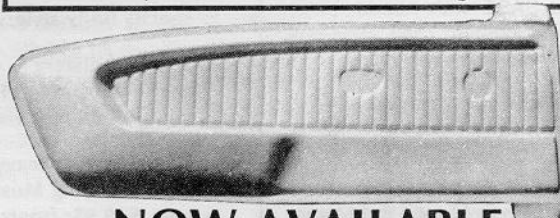

NOW AVAILABLE

Finest quality pony door skins at remarkable low prices.

ONLY \$119.95 Pair
Installed Just \$139.95 Pair

All parts are exchange. VISA, MasterCard, COD. Other plastic parts rechromed. Call or write for quote. Add 10% handling and shipping charge.



Information Phone:
 817-838-3131



CLASSIFIEDS

For '67 MUSTANG: Black conv. top and bows, \$75; AM/8, \$75; tilt \$100, white OH console, \$25; deluxe white coupe int., \$150. (215) 328-0861 T. Heraty, 325 Ballymore Rd., Springfield, PA 19064.

Woodgrain Steering Wheels, NOS, '67 orig. equip. for MUSTANG, Fairlane, Ford, Falcon. \$280. '65-'66 Orig. equip. For MUSTANG, 7 litre, Fairlane, \$310 (UPS pre-paid) Toby Gorny, Route 5, Bryan, OH 43506 (419) 636-2475.

1-67 woodgrain steering wheel, EC, no cracks, 2-66 8000 rally pac, EC, 1-65 6000 rally pac, GC, 1-67 AM/FM. works good, 1-67 AM/8, works OK, many other hard to find parts. Call Don (206) 847-2623.

1970 MUSTANG, factory 2bbl carb, 351, \$30, MACH-I rocker molding, both sides, \$30, standard instrument clusters, L/R sides \$25, dual mirrors \$15 ea., quarter panel extensions, front, \$20 ea. Rear fastback \$15 ea., rear honeycomb panel for MACH-I \$10. (313) 671-6127.

'65-'73 MUSTANG consoles, \$100 up, 68-69 chrome 6T wheels, 65 rally pack, 67-68 tacks/clocks, '65-'70 rear fastback seats; '65-'70 int. parts. Joe Russell, MacGregor Dr., Mahopoe, NY 10541 (914) 628-4866.

MUSTANG '67 under dash AC, complete \$135, '68 factory AC standard dash vent panels \$50, '69 conv. inside rear quarter panels \$30, Michael Bland, 616 Pima, San Jose, CA 95123 (408) 224-1374.

4 chromed styled steel wheels for '68-'69 MUSTANG. Complete with trim rings and plain caps. EC. With or w/o 4 new P215 x 70 radials \$500 w/tires, \$400 w/o, OBO. (302) 368-2236.

Parting out 1973 MACH I — most parts good or restorable. Send SASE with needs. (513) 866-5704, Marvin Scothorn, 610 Overland Trail, Miamisburg, OH 45342.

PARTS WANTED

WANTED: '65-'66 MUSTANG conv. pony seats (front/rear). Colors: blue/white, red or black preferred, reasonably priced. CALL COLLECT (912) 888-0318. Marion McKinney, 811 Mercer Avenue, Albany, GA 31701.

WANTED: 1 set R+L retainer — roof-outside vinyl cover, side Ford P/N C6GY6353728A, for '66 MUSTANG H/T. Gene Millspaugh. (504) 275-6460. Aft. 6:30 p.m. CST.

WANTED: Int. parts in EC for 1969 MACH I, must be black. Contact Jerry Breeden (615) 938-1955.

WANTED: 1970 BOSS 302 exhaust manifold for the left (drivers) side or a complete pair. Carl D. Dunn, Rt. 1, Rutledge TN 37861. (615) 828-4096.

PARTS WANTED

WANTED: Left side BT Exhaust system for 66 MUSTANG, (C6ZZ-5030-F) or info on where I can get exact match replacement. Jim Kimsey, 3433 Creek Circle, Guntersville, AL 35976 (205) 582-6755.

WANTED: 1 set SS wheels, w/caps and rings, for 1965 MUSTANG. Must be GC, reasonable. Rodney Hager, 1847 New Franklin Rd., Chambersburg, PA 17201.

MISCELLANEOUS

WANTED: Picture of original 1966 MUSTANG with fender skirts. Will buy book, if you have one with picture in it. R.L. McKinley, 2225 Winston Ave., Louisville, KY 40205.

Ford Dealer Promo models. 1965 blue MUSTANG coupe and 1966 brown MUSTANG 2 x 2 with working Philco radio, both EC. Make offer. Tom Droege, 3617 Horizon Drive, Lancaster, PA 17601 (717) 285-5367.

Liberty Bell Grand National souvenir pewter plates — similar to trophies, but w/"souvenir" printed on front. 9" - \$20. 6" - \$15. Checks to: 1st PA MUSTANG Club, Box 3291, Wescosville, PA 18106.



1965 - 70
MUSTANG

New Parts
Upholstery
Accessories

- Trunk Mats — plaid or speckled custom tailored for all models 65-70 specify body style; only \$21.95
- Seat Upholstery — complete sets, any color from \$194.95, pony style for 1965-66 models also available
- Floor Mats — heavy rubber with raised running Mustang, fronts only, \$29.95; fronts and rears \$39.95; for all years and models (specify color)
- Radiators — O.E.M., new complete radiators, just bolt-in, from \$125.

Send For Your FREE Price List Today!

Shipping—10% on orders less than \$150, all others shipped free. All C.O.D.'s add \$1.50. CA residents add sales tax. VISA-Master Charge welcome

427 N. Anaheim Bl., Dept. F
Orange, CA 92668
(714) 634-4936

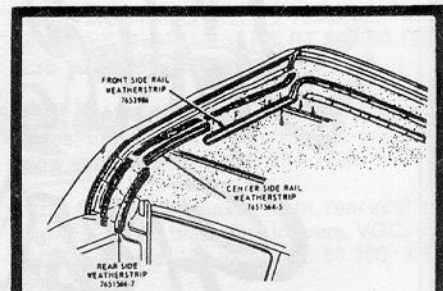

NOW AVAILABLE
1964-1968 MUSTANG
CONVERTIBLE TOP
SIDE-RAIL WEATHERSTRIP

NOW SHIPPING...

Flawless, Compression Molded Convertible Side-Rail Weatherstrips. A Satisfaction Guaranteed Alternative to UGLY, CRACKED, and ROTTED Originals or other poor reproductions. Protects Expensive Restored Interiors and Prevents Annoying Drafts.

FEATURES...

- Compression Molded in Handmade molds using Durable E.P.D.M. stock • Guaranteed better than Original Fit and Finish • Precision molded cornerpieces (DOGLEGS) that not only fit better than the original, but also look better • Full length molded-in steel backbones with welded studs same as original • Do not confuse this NEW product with the cheaper extrusion type reproduction • These are proven quality parts, manufactured by a company with many years experience specializing in convertible top weatherstrip. Our parts have been installed on many show winning cars.

\$159.95 COMPLETE SET

Dealers Inquire...We Have An Excellent-Dealer Program!

Make Checks Payable To:
DAVE McBRIDE
C/O CALIFORNIA CLASSICS
645 E. McGlincy Lane
Campbell, CA 95008
(408) 377-2324

Feldman Trailers
Box 1687
Bowling Green, Kentucky 42101
(502) 843-4587 We can deliver anywhere. 782-2734

RESTORATIONS • REPAIRS •
DETAILING • MODIFICATION

64½ - 73 MUSTANGS
SHELBS

CARS & PARTS
BOUGHT • SOLD • TRADED

LEE MATHIAS
3853 MOON STATION RD.
KENNESAW, GA 30144
(404) 427-0382



Hours
Mon.-Fri. 9-6
Sat. 9-4

ACCESSORY	QTY.	PRICE
Mustang Club of America Cloth 3" Emblem	_____	\$ 2.50
Mustang Club of America Cloth 8" Emblem	_____	\$ 6.00
Mustang Club of America T-Shirt Adult (S-M-L-XL) Sale (while they last)	_____	\$ 3.50
Mustang Club of America Jacket** Unlined — Adult (S-M-L-XL)	_____	\$22.00
Mustang Club of America Winter Jacket** Lined — Adult (S-M-L-XL)	_____	\$29.00
Mustang Club of America Windshield Decal	_____	\$ 1.00
Mustang Club of America Front License Plate	_____	\$ 3.00
Mustang Club of America Official Cap	_____	\$ 5.50
Mustang Club of America Judging Rules	_____	\$ 2.00
DASH PLAQUES (All Past Show Plaques, as available, includes postage, each		\$.75
Back Issues of "The Times"	_____	\$ 2.00

Note Regarding Accessories:

These accessories are made available by MCA as a service to the membership. Items are purchased in quantity and made available to the membership to recover costs and handling. Present stock is being purged and a new list of accessories is being examined. Frank White handles this service to members on a volunteer basis. Four to six weeks required for delivery. Contact Frank for quantity discounts where available.

**** JACKETS INCLUDE MCA PATCHES**

Due to the rising cost of postage, please add ten percent for shipping.

SEND CHECKS TO:
MCA ACCESSORIES
 % FRANK WHITE
 418 Hicks Farm Road • Acworth, GA 30101

Sharp Shooting

Of all the questions we are asked, without a doubt the most frequent is "How can I get my car on the cover of the magazine?" First on the list of requirements is to have some appropriate, if not spectacular, photographs.

The strictest requirements are for the front cover. For this we need a vertical shot in which the camera is held vertically rather than horizontally. We prefer 35 mm photos, but will accept the normal size slide or larger. The photograph or color transparency must be in proportion to 8½" by 11", which is the size of the magazine cover. The less the print must be enlarged, the better. Many covers enlarged from a 2¼" color slide became "grainy" (an undesirable finish) when they must be enlarged to cover size. In short, if you can't furnish a color transparency 2" by 3" or larger, we prefer a 35mm photograph. In color, of course.

As far as the composition of a front cover photo is concerned, the car should be relatively in the center of the picture with slightly more space at the top than at the bottom of the photo. The printer tells us that consistency is the most important factor in the foreground and background of the picture. A light blue sky is a very good background, because the name of the magazine may easily be printed on top of it. A gravel road makes a good foreground, because "Mustang Club of America" can be printed over it. Dark grass could also be used; in this case, the printing would be reversed. A mixed background or foreground is not desirable.

The color transparency or photo for the back cover should be taken with the camera held horizontally. The background is not restricted from a composition standpoint. We like to have Mustang owners in these pictures, if the owners prefer.

For pictures to be used on the inside of the magazine, we definitely prefer black and white photos with a glossy finish. They reproduce much better

than color pictures or slides. For use inside the magazine, we must get slides developed into pictures before we can use them. Please do not send Polaroid pictures.

A shutterbug offers these hints for getting the best pictures of your Mustang:

Avoid shadows and overcast skies.

Be sure surrounding area is uncluttered and free of trash or anything else that might detract from your car.

Avoid positioning the car where it might appear that telephone poles, trees, signs or similar objects are "growin'g" out of the car.

If you have a convertible, take pictures with the top both up and down.

Shoot your Mustang from different angles; don't make them all from eye-level. Try kneeling, or using a step ladder.

Experiment. Vary the standard side, back, front shots. Try various angles to show off the complete beauty of the lines of your Mustang.

If you have a light colored or white Mustang, use a contrasting dark background to dramatize your car. If the Mustang is a dark shade, try highlighting it against a light background.

When taking pictures of the interior and engine compartment, use a flash attachment to fill in dark areas that may shadow if you don't use a flash.

If your Mustang has been restored to show and the undercarriage is detailed, or if you have modified your Mustang (including the undercarriage), try to get a picture or two of the undercarriage.

When taking exterior pictures, make sure the windows are down to avoid glare from the glass.

Lit parking lights will accentuate the lower half of the car.

Most important of all, your Mustang does not have to be a first place winning show car to be on the cover. We need those Mustangs used for daily transportation. We need *all* Mustangs,

not just the very early models: Bosses, Shelbys, MACH F's Grandes, GT's, and the rarer models such as the California Special, 1972 Sprint model, Bandidos, T5's...Every Mustang has its story, and you need not be a professional photographer to take the photographs to illustrate it!

Snobl Update

In the February, 1982 issue of Mustang Times, we met a young man from Czechoslovakia - Frantisek Snobl - with a story that touched many Mustangers. Maybe it was his open admiration and lavish affection for the Mustang and our club; perhaps it was the way Mustang seemed to symbolize America and freedom for him; it could have been the poignant way he expressed his enormous grief over the destruction of his Mustang. At any rate, we got a lot of mail about the story and donations from quite a few members.

Teresa Vickery is coordinating efforts to get Mr. Snobl the parts he needs to repair his Mustang. Following is an update on what he has been sent:

\$80.00 in donations

Three wheelcovers from Jose Rivera of California.

Script Mustang fender emblems from Lee Mathias of Mustang Farm.

One wheelcover, left and right complete headlight assemblies, one outer bumper brace, hood latching assembly, grille - all of this from Teresa.

With the help of Larry Fincher of LaGrange, Georgia, she has located an air conditioning condenser.

Frantisek himself has found the turning gear and new convertible top he needs.

The first shipment of parts was mailed to Frantisek on January 7, 1983; it will take approximately three months for the package to reach him. Teresa reports that she is still searching for parts and has no intention of giving up.

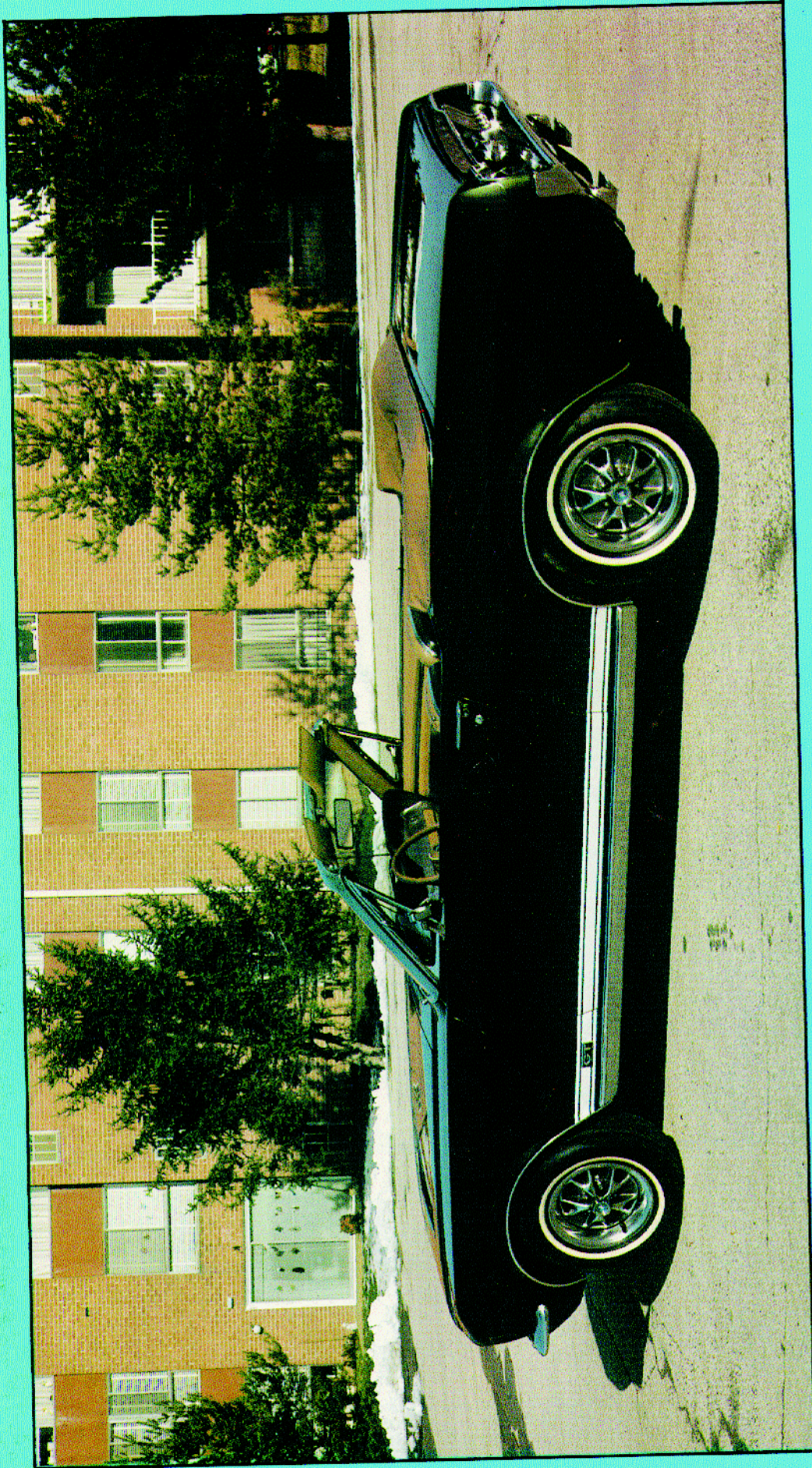

RUSH TO

FROM
NATIONAL HEADQUARTERS
THE MUSTANG CLUB OF AMERICA, INC.
P.O. BOX 447
LITHONIA, GEORGIA 30058