

Vol. 15 No. 1

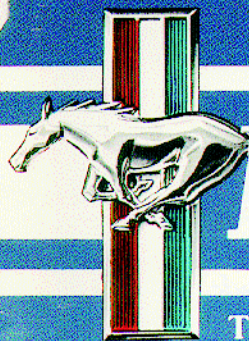

MUSTANG TIMES

The Official Publication of The Mustang Club of America

January 1991



WORLD'S LARGEST MUSTANG PARTS CATALOG

**IF IT'S AVAILABLE FOR YOUR
1964-73 CLASSIC MUSTANG
WE'RE STOCKING IT!**

Wheels	Speedometer Cables
Brakes	Bumpers
Steering	Air Conditioners
U-Joints	Heater parts
Radiators	Stripe Kits
Water Pumps	Weather Stripping
Grilles	Rubber Parts
Fuel Lines	Carpeting-Molded
Carburetor Kits	Floor Pans
Alternators	Patch Panels
Wiring	Upholstery - Including
Lights	"Pony" and "Mach I"
Fenders	Decals
Hoods	Misc. Hardware Kits



Send \$5.00 for your complete catalog. Over 378 pages, complete with illustrations and prices. Over 7,000 items now in stock.



MUSTANG PARTS OF OKLAHOMA

6505 S. Shields • Oklahoma City, OK 73149-1311
Phone: (405) 631-1400 FAX (405) 631-1401
Store Hours: Mon. - Fri. 9-7; Sat. 9-3

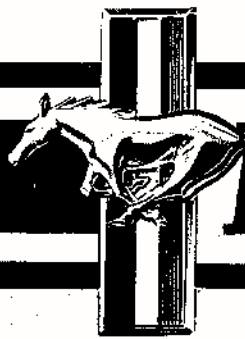

MUSTANG TIMES

\$3.00

Jo

The Mustang Club of America

1964 1/2



1991

1991

FROM
NATIONAL HEADQUARTERS
THE MUSTANG CLUB OF AMERICA, INC.
P.O. BOX 447
LITHONIA, GEORGIA 30058
(404) 482-4822 (9 AM - 1 PM)

FOR ADDRESS CHANGES

Please allow at least six weeks for change of address and enclose old address as well as new address, including, if possible, an address label from a recent issue. Send change to address at left.



Founded - 1976

DATED MATERIAL

Second Class
Postage
PAID
Lithonia, GA
30058

All Mustangs 1965-70 Shelbys

... the most exciting American sports cars

**NOW THERE'S AN INTERNATIONAL CLUB FOR OWNERS OF THESE
SUPERB AUTOMOBILES. WE'D LIKE TO TELL YOU ABOUT IT.**

It's called the Mustang Club of America, and you'll find representative members through the United States and Canada ... even in some foreign lands.

Why a Mustang Club?

MCA was formed to band together owners of this classic automobile ... to provide a medium of exchange for ideas, technical information, amusing reminiscences, and the purchase of parts — often at substantial discount. Lasting friendships have been formed through regional get-togethers and as a result of the Club's national meets.

Prized Possession

Mustangs and Shelbys are greatly in demand these days, and a good one is rarely offered for sale because discriminating owners realize they possess an automobile of advanced design and beauty, one that will retain its saucy, modern appearance for years to come with a little loving care. These people have insight and sound judgment, and the Mustang Club of America wants to help them preserve their little cars.

For many such judicious and intelligent folks the savings in time and money in parts location alone have been reason enough for being members of our growing institution. Some dote on tech tips, while for others, the camaraderie that exists between persons of like tastes is their compelling reason for belonging to the Mustang Club of America.

What Membership Means

Whether your Mustang or Shelby serves as everyday transportation, a relaxing plaything, or both, you'll find valuable help in your restoration and maintenance problems in the Tech Tips printed in the club publication, the MUSTANG TIMES. This informative, illustrated periodical is distributed every month, and contains many interesting features besides the mechanical information mentioned ... articles.

Enroll-A-New-Member — TODAY! —

about member cars, news of chapter events and activities, all profusely illustrated with photos, diagrams and cartoons. In addition the MUSTANG TIMES offers an advertising service to those wishing to buy, sell or swap parts or cars.

Tours, meets, rallies, picnics, camp-outs and other outings designed to encourage group participation (with the Mustang or Shelby, that is) are regularly conducted by the various chapter groups located throughout the United States and Canada. There is probably one near you! You are warmly invited to attend any of these friendly chapter meetings or events.

Who Belongs?

MCA boasts people of all ages — from those born before the Turn of the Century to teen-agers still in school. Among the members are professional men and women — doctors, dentists, lawyers — individuals who could certainly afford newer, more costly vehicles if they chose. Widows, widowers, single persons and married all find something of value in their memberships, for the pride of owning the Classic Mustangs and Shelbys, the exclusive personal car of distinction, keeps them driving a vehicle of a past and present decade. For this company of people, there's a whale of a lot of fun in driving a Mustang or Shelby. To them it's a daily holiday, a pick-me-up that never lets them down. It's full expression of their love of life and the chance to live the life they love. MCA wants to keep them that way.

Premium Packet

Every new member receives a new member packet upon payment of initiation fee and dues. Also, many items such as patches, hats, decals, etc. are sold to members only at substantial savings.

MCA Hotline 404-482-4822

Monday - Friday 9 a.m. - 1 p.m. (E.S.T.)

**OUR OBJECTIVE: EVERY MUSTANG AND SHELBY
OWNER A MCA MEMBER
APPLICATION BLANK BELOW**

PLEASE ALLOW 6 WEEKS DELIVERY OF FIRST ISSUE

CUT ALONG THIS LINE



Founded 1976

MEMBERSHIP APPLICATION

YES!!! I want to join the most responsive and fastest growing organization in the world dedicated to the preservation, care, history and enjoyment of all year Mustangs — 1965-1970 Shelbys. Enclosed is \$25.00 U.S./\$30.00 Canada (U.S. Funds)/\$50.00 Foreign (U.S. Funds).

Please send my new member's packet immediately and the next 12 issues of *The Mustang Times*.

NATIONAL HEADQUARTERS • P.O. BOX 447 • LITHONIA, GEORGIA 30058-0447

Name _____ Spouse _____

Address _____

City _____ State _____ Zip _____

Please Type, Print or Affix Address Label

OWNERSHIP NOT ESSENTIAL ENTHUSIASM IS

THE MUSTANG CLUB OF AMERICA

P.O. BOX 447 LITHONIA, GEORGIA 30058 404-482-4822 (9 AM - 1 PM Mon.-Fri. e.s.t.)

OFFICIAL ACCESSORIES

MCA Windshield Decal	\$1.00
MCA 3" Cloth Emblem	\$2.50
MCA Official "1989-90" Judging Rule Book	\$3.00
MCA T-Shirt*	\$8.95
MCA Caps	\$5.50
Tags (State Year of Car)	\$4.50

*State Size When Ordering

Add \$1.50 Postage And Handling For Shirts, Caps & Tags



Send check/money order to:

MCA Accessories
P.O. Box 447
Lithonia, Georgia 30058-0447

Old Address	New Address
Name _____	Name _____
Address _____	Address _____
Membership No. _____ <small>(Membership number from membership card.)</small>	Mail to: Mustang Times P.O. Box 447 Lithonia, GA 30058

MOVING?
Allow 6 to 8 weeks
for processing.



**On A Budget?
Ten Items
All Under 50 dollars!**

Your Mustang's
restoration is just a phone
call away!

ORDER TOLL-FREE

1-800

442-8333.

Fax
(916) 334-3746

Tech. Information
(916) 334-0190



- Visa
- Discover
- Master Card
- American Express
- UPS/COD
- Check or MoneyOrder



Get our Restoration Parts
Catalog, 1990 update
and High
Performance
catalog all for only
\$3.00 ppd.



DUAL POINT CONVERSION KIT and high performance **DISTRIBUTOR CAP**. Dual point kit includes base plate, 2 point sets, and condenser for higher RPM firing! HiPo distributor cap uses brass contacts, yet looks stock. Buy both and save! **ONLY \$42.95**

Six Blade A/C type FAN BLADES for '65 - '70 small block V-8. Increase cooling! Excellent reproduction! **ONLY \$49.95 EACH!**

MUSTANG FLOOR MATS, aftermarket style. Heavy duty black rubber with Mustang logo in red, white, blue and silver. Set of four for front and rear. Fits all years. **ONLY \$34.95!**

STANDARD DOOR PANELS for '65 - '68 Mustangs with standard interior. All colors. Excellent quality! **\$49.95 A PAIR**. Regular \$69.95 a pair

AUTOLITE VOLTAGE REGULATORS, concours quality reproduction. Specify black with silver stamp or blue with yellow stamp. **\$29.95 EACH!**

Show Quality **FUEL LINES**, pre-bent for '65 - '70 V-8 and 6cyl. engines. These fit between stock fuel pump to carb. **ONLY \$16.00 EACH!**

BATTERY HOLD DOWN KITS for '67 - '70 Mustangs. For group 24 battery - all metal kit. High quality! **ONLY \$9.95 EACH!**

BATTERY CABLE SETS, concours quality. Original type clamps, cable and part no. Specify V-8 or 6 cyl., any year of Mustang. **\$49.95**

RADIATOR HOSE SET, show quality. Includes upper and lower radiator hose and bypass hose. '65 - '67 V-8 only. Stamped with current part no. and FoMoCo script. **\$29.95 SET**

TRUNK MAT KIT. For your '65 - '73 coupe, convertible, or fastback. Includes trunk mat with felt backing, tire jack bag, and spare tire cover. **ALL FOR ONLY \$29.95!** Plaid only, as shown.

(Overnite Bag with Mustang Logo, Not Included, \$16.95)

COMPARE QUALITY • COMPARE PRICE • COMPARE SERVICE!

MUSTANG PARTS

money back guarantee!

BEFORE YOU BUY ...
COMPARE paddock parts
 THERE IS A DIFFERENCE!



the world's largest supplier of mustang parts

BUMPERS

Highest quality reproduction bumpers available.
 65-70 Front or rear ... from 79.95
 65-68 Bolt kit 11.95

FRONT FENDER

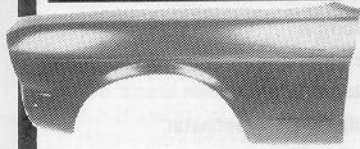

Special on '64-'66 repro front fender.
 64-66 Frt Fender ea 129.95
 64-66 Frt Fender pr 259.90

GAS TANK

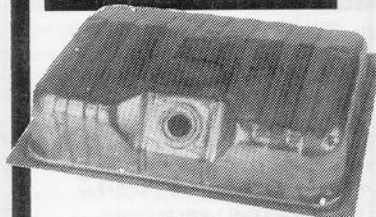

Now available an exact replacement tank. Made in the USA, it is available with the correct drain plug that is not available on any other tanks.
 65-68 C5ZZ 9002DRP
 w/drain plug 139.95
 65-68 C5ZZ 9002DR
 w/o drain plug 114.95

STEREOS



New factory made to fit AM/FM cassette stereos, 14 watts loaded with features. Fits into the dash without modifications. Speakers available. Many more models to choose from.
 65-66 MS-USA2 149.00
 67-73 LM-USA2 149.00

STEERING

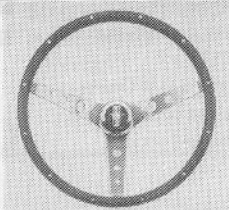

Beautiful walnut finish. Complete with Mustang emblem & adapter. 15" dia.
 65-67 9663294R **\$89.95**
 68-77 9663249R

LEAF SPRINGS

65-73 Leaf Springs pr. 149.95

INTERIORS

Available in original colors. Just a partial list - many more models IN STOCK for immediate delivery. Best quality.

65-68 Standard
 2 buckets 117.90
 Complete set 159.95
 Door panels pr. 69.95
 65-66 Pony
 2 buckets 144.90
 Complete set 214.95
 Door panels pr. 134.95

CHARGE IT!

MASTER CARD
 VISA
 AMERICAN EXPRESS
 DISCOVER CARD

STORE HOURS:
 Mon.-Fri. 8 to 5
 Saturday 9 to 3

YOUR "ONE SOURCE" FOR MUSTANG PARTS!

MOLDED CARPET

The very best molded carpet. Correct blend of material 80/20 for 65-68, 100% nylon for 69-73. Full cut 30 ounce 1/2" underlay pad bonded to the carpet.

65-73 All body styles 99.00
 70-73 Mach 1 w/insert 144.95
 65-73 Carpet underlay 34.95

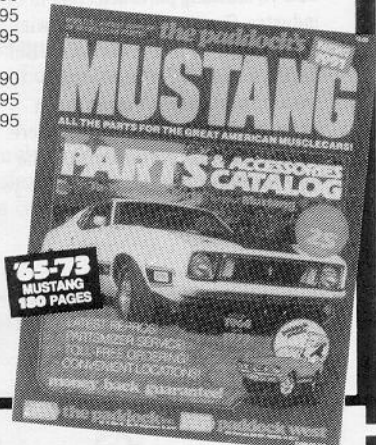

NEW 1991 MUSTANG CATALOG
 Now available is The Paddock's all new 180 page Mustang catalog. You'll appreciate the way our parts are broken down into categories with a Table of Contents & expanded index for those hard to find parts.

GET ON OUR MAILING LIST!

NAME _____
 ADDRESS _____
 CITY _____
 STATE _____ ZIP _____

For just \$3.00 we'll send your MUSTANG catalog to you by mail along with placing your name on our mailing list. Simply pick up your phone and call either The Paddock 1-800-428-4319 or Paddock West 1-800-854-8532 and we'll place your order on your Visa, MasterCard, American Express or Discover Card. **ACT NOW!**

the paddock inc.
 221 W. Main, Box 30, Dept. MT, Knightstown, IN 46148

IND. WAREHOUSE
800-428-4319
 Info Line: 317-345-2131

paddock west
 1663 Plum Lane, Box 8547, Dept. MT, Redlands, CA 92375

CAL. WAREHOUSE
800-854-8532
 Info Line: 714-335-3137

WEATHERSTRIPPING GAS CAPS AIR CLEANERS WIRING HARNESS TAILLIGHT ASSEMBLY DOOR HANDLES WINDOW REGULATORS ANTENNAS ROCKER PANEL HOLDING WIRE WHEEL COVERS BUMPER SHEET METAL PATCH PANELS TRAY HEADER TAIL PIPE EXTENSION ENGINE PAINT

We Admit . . . We Are Particular.

The 1990's promise to be another decade of escalating prices for American-made collector cars. As an owner (or future owner!) of a classic Mustang you are aware of your car's value, and no doubt want only the finest parts available. At Larry's we're here to help your restoration project become a quality investment.

Lowest Prices in the Industry. Always.

Best of all, we continue to have the most competitive pricing around. Compare our prices with the competition and we'll beat them by a long shot. Of course this converts to great savings on your part and you still have money left to finish your restoration project. We continue to prove that year after year.



'90-'91 Catalog

Concourse-Quality Parts - Service.

Over the 20 years that Larry's Thunderbird & Mustang Parts has been in business we've gained a reputation among enthusiasts for having the most complete and comprehensive 64 1/2-'73 Mustang parts selection in the industry. Our goal is concourse-winning quality. And we've achieved that. But having a huge selection of award-winning parts doesn't mean much unless we know what parts go where. No problem. Our partsmen have the experience necessary to make sure you get what you need.



Comprehensive Catalog! (The Wish List!)

Larry's offers our current 64 1/2-'73 Mustang Parts Catalog for only \$2.00. To get your hands on this book full of illustrations, photos, and part listings, call, write or FAX us your request. We'll send your copy out as soon as we can.

Ordering Parts is Easy.

At Larry's we make ordering parts convenient. Use our toll-free number and charge to your credit card (Visa®, Mastercard®) or have it sent C.O.D. Orders also accepted by FAX. You can bet on Larry's to give you the parts and service you need!

We've got the parts you need!

- Upholstery
- Interior Items
- Engine Components
- Clutch
- Brakes
- Electrical
- Weatherstripping
- Exterior Trim
- Body Panels/Sheetmetal
- Window Glass
- Audio Components
- Suspension Components
- Bumpers
- Decals
- Literature

EXAMPLES OF GREAT PRICES & PARTS YOU'LL FIND AT LARRY'S

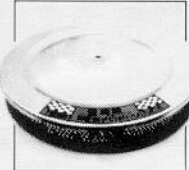

AIR CLEANER ASSEMBLY
Original Type 35.95
Aftermarket 18.95
(both include element/decals)

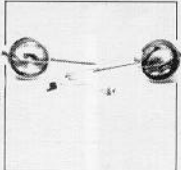

GT GRILLE BARS/LAMPS
'65/'66 Bar/Lamp... 169.95
'67 Bar/Lamp..... 215.00

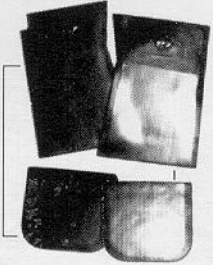

MUSTANG THROW MAT
Fits '65-'73 Cars
Blue, Red,
Black, White 39.95

CATALOG REQUESTS CALL 714-871-6432

Parts Orders Call 1-800-854-0393
(Inside CA) 1-800-698-2473
FAX 714-871-1883
HOURS: Mon.-Fri. 8:30 a.m.-6:00 p.m.
Sat. 9:00 a.m.-1:00 p.m.



511 S. Raymond Ave., Fullerton, CA 92631

Mustang Club of America, Inc.

Official publication of
The Mustang Club of America, Inc.
P.O. Box 447
Lithonia, GA. 30058-0447
Publisher: Jack Yeager
Editor: Steve McMullan
Assistant Editor: Kitty Wilmot
Advertising Manager: Steve McMullan
For advertising information call (404) 979-4924
Monday through Friday.

National Headquarters Office:

Bill Koivu (404) 482-4822

National Regional Group Director:

Horace A. Wood
3653 Altadena Drive
Birmingham, AL. 35243
(205) 967-1705

National Head Judge:

Bob Perkins
North 3183 Highway 26
Juneau, WI. 53039
(414) 696-3788

National Show Director:

Bill Dillard
2536 Old Rome-Dalton Rd NW
Calhoun, GA 30701
(404) 625-2677 (evenings)

For any correspondence pertaining to new membership, club information, renewals, national club business, or **The Mustang Times**, please address correspondence to National Headquarters address: The Mustang Club of America, Inc., P.O. Box 447, Lithonia, GA. 30058 or phone National Headquarters at (404) 482-4822 (9 a.m.-1 p.m. EST Monday through Friday). No collect calls, please!

Mustang Times (ISSN 0744-2572) is published monthly by the Mustang Club of America, Inc., 7138 Maddox Road, Lithonia, GA. 30058. Membership dues are \$25 per year, which includes \$20 for twelve monthly issues of **Mustang Times**. Second class postage paid at Lithonia, GA. 30058. Postmaster: please send address changes to **Mustang Times**, P.O. Box 447, Lithonia, GA. 30058.

It is requested that any transaction with the club, including dues payment, be made by check or money order payable to The Mustang Club of America. Cash must be sent at your own risk. Please notify the club of any change of address immediately and allow a minimum of six weeks for processing.

Mustang Times and The Mustang Club of America do not accept any responsibility for the accuracy of advertisements and/or advertisers. Any advertisers who have proved unreliable or who have been named in legitimate complaints from MCA members will not be allowed to advertise. Liability for clerical and/or typographical errors which may appear in **Mustang Times** is limited to the correction of same.

© 1991—Mustang Club of America

January, 1991

Vol. 15, No. 1



Pantera-Powered Pony Has Proud Past

John Adams of the Front Range Mustang Club in Colorado stopped by an auto dealer in January of 1990 and found a '67 Mustang fastback he said was "modified to my liking." But when John got the Pony in his corral at home, he was shocked to learn that he had gotten more than he bargained for. See the full story on Pages 21-23 of this month's issue of **The Mustang Times**.

1991 ANNUAL MEETING SCHEDULED: It's time for the Mustang Club of America's 1991 Annual Meeting and Installation of New Officers. For details on this year's annual meeting, see Pages 10 and 17.

50,000 MUSTANGS AND COUNTING: The "In Search of Mustangs" project has far exceeded the expectations of Jim Smart and Jim Haskell — with the total census now approaching the 50,000 mark. See the latest update on the "In Search of Mustangs" project on Pages 32 and 33 of this issue.

Table of Contents

MCA News And Notes	6
President's Page	8
Publisher's Page	10
Reader's Forum	11
Pensacola MCA Show Ad	14
Disney World MCA Show Ad	19
Cover Story	22-23
Feature Car	24-25
Regional News	26-29
Horse Show	30
Owner's Information Sheet	31
In Search Of Mustangs	32-33
Troubleshooter	34-35
Welcome New Members	37
Calendar Of Events	38-40

1990 National Officers

Charles Hampton	President
Bill Dillard	Vice President
Sandi Dillard	Secretary
Bill Koivu	Treasurer
Jack Yeager	Publisher
Ed Hunter	Sergeant-at-Arms
Tom Gattis	Sergeant-at-Arms
Tom Bader	Parliamentarian
Bob Perkins	National Head Judge
Horace Wood	National Regional Group Director
Bill Dillard	National Show Coordinator

MCA National Board of Directors

Serving through January 1993

Max Craft	Winston, GA
Sam Dean	Greenville, SC
Junior Downer	Chattanooga, TN
Tom Gattis	Conyers, GA
Charles Hampton	Anderson, SC
E.G. Hardy	Hermitage, TN
Ed Hunter	Powder Springs, GA
Mike Hillman	Chattanooga, TN
Jim Johnson	Chattanooga, TN
Lena Johnson	Chattanooga, TN
Charles LaTaste	Oxford, AL
Sue Osborn	Buford, GA
Amanda Perry	Kennesaw, GA
Ricky Simmons	Demorest, GA
Bob Vickery	Lithonia, GA
Teresa Vickery	Lithonia, GA
Horace Wood	Birmingham, AL

Serving through January 1992

Joe Antrican	Powell, TN
Jo Ann Antrican	Powell, TN
Tom Bader	Montgomery, AL
Randy Church	Baldwin, GA
Bob Deale	Marietta, GA
Pat Downer	Chattanooga, TN
Bill Dillard	Calhoun, GA
Jack Hinson	Cartersville, GA
Barbara Koivu	Snellville, GA
Bill Koivu	Snellville, GA
Tommy Gilstrap	Greenville, SC
Don Perry	Kennesaw, GA
Walter Scott	Greenville, SC
Bruce Weiss	Melbourne Beach, FL
Kitty Wilmot	Roswell, GA
Lee Wilmot	Roswell, GA
Jack Yeager	Decatur, GA
Ken Yeager	Decatur, GA

Honorary Members

Steve McMullan	Snellville, GA
Bob Perkins	Juneau, WI

November Board Meeting Minutes

By SANDI DILLARD
MCA National Secretary

The meeting of the Board of Directors of The Mustang Club of America was called to order by the president, Charles Hampton, Tuesday, Nov. 13, 1990.

Roll call was made with 33 directors responding.

The minutes of the October meeting were read and approved.

The treasurer's report for October was submitted and approved.

Visitors were recognized and included Shane O'Neal of Greenville, SC; Dexter White and Larry Maddox from Model City Mustang Club; Russell Gilbert from Cherokee Mustang Club; and Mike Holliman from Chattanooga, TN.

OLD BUSINESS

Nominations for the Board of Directors were opened to replace directors with terms expiring in January, 1991.

After nominations were made an election was held with the following MCA members being elected to serve as members of the Board of Directors through January, 1993:

Max Craft	Winston, GA
Sam Dean	Greenville, SC
Junior Downer	Chattanooga, TN
Tom Gattis	Conyers, GA
Charles Hampton	Anderson, SC
E.G. Hardy	Hermitage, TN
Mike Holliman	Chattanooga, TN
Ed Hunter	Powder Springs, GA
Jim Johnson	Chattanooga, TN
Lena Johnson	Chattanooga, TN
Charles LaTaste	Oxford, AL
Sue Osborn	Buford, GA
Amanda Perry	Kennesaw, GA
Ricky Simmons	Demorest, GA
Bob Vickery	Lithonia, GA
Teresa Vickery	Lithonia, GA
Horace Wood	Birmingham, AL

Jim Osborn reported on the National Judges' Meeting held in October in Juneau, WI. He said the meeting went very well. The 1991 National Judges' Meeting will be held in Atlanta, GA.

Jim Osborn resigned from the Board of Directors. Tommy Gilstrap was nominated and elected to replace him.

Bob Deale read a letter to *The Mustang Times* and *Mustang Monthly* regarding some of the recent environmental initiatives under way in the United States and their impact on our hobby. To recap, he made the following four points on this program:

1. The program was entirely voluntary. All the pre-1971 cars involved in the program were purchased for \$700 by Unocal. No one "took" these cars.

2. The program was limited in duration, scope and location. The company had hoped to scrap 7,000 pre-1971 vehicles. About 7,400 cars were actually scrapped. The program ended in September.

3. No Federal office or agency was involved in this program.

4. The SCRAP program was linked to a "Smog Fighter" program and was limited to the Los Angeles Basin in Southern California.

NEW BUSINESS

Jim Osborn brought several examples of trophies for the board to look at in the event the board decides to pursue this avenue. A motion was made and approved to pursue the cost of trophies and to decide at a later date whether to go forward with the motion.

Carolina Regional Group presented a logo for use on the club's letterhead. The logo was inspected and approved by the board.

Charles Hampton read several letters to the board.

A nominating committee was appointed for the election of new officers for 1991. The committee consists of Bruce Weiss, Sue Osborn and Ricky Simmons.

Bob Deale presented six parts from California Pony Cars. These included a 1964½ horn ring, T-5 horn ring, 1966 standard horse and corral, 1966 fog light bar, 1966 console end cap, and 1967 fog light bar. All were inspected and approved.

Board members were reminded of the annual meeting and installation of officers, scheduled for Jan. 26, 1991.

With there being no further business, the meeting was adjourned. The next meeting of the board will be Tuesday, Dec. 11, at 7:30 p.m. at the Marriott Courtyard Hotel, Windy Hill Road and I-75 in Marietta, GA.

The MCA Board of Directors meets monthly. All board meetings are open to any card-carrying MCA member.





MUSTANGS unlimited inc.

185 ADAMS STREET,
MANCHESTER, CT 06040

TO ORDER, CALL TOLL-FREE
1-800-243-7278

SAME DAY SHIPPING AVAILABLE!

Your One-Stop Mustang Shop!

Please specify year, and right or left when ordering

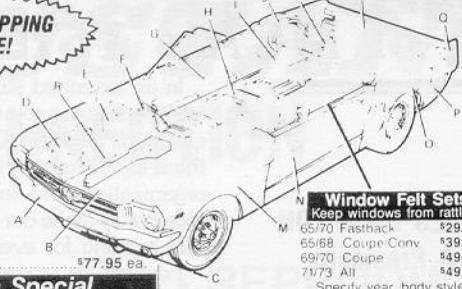

A. Bumpers.

Best quality! Specify year, front or rear. 65/70.....\$77.95 ea.

Floor Pan Special

Incl. 1 pr. A 107 fronts, & 1 pr. A108 E rears. FPS100.....\$169.95

B. Hood Assembly.

65/66, 56612.....\$149.95 ea.
67/68, 766121.....\$169.95 ea.
NEW! 67/68, 766122, w/ Indic.....\$199.95 ea.

C. Valances.

65/66 Front, 57939.....\$39.95 ea.
67/68 Front, 77939.....\$39.95 ea.
69 Front, 97626.....\$74.95 ea.
70 Front, 7626.....\$74.95 ea.
65/68 Rear* (spec. yr) Lamps or exhaust \$34.95 ea.
69/70 Rear*.....\$49.95 ea.

D. Fender Aprons.

Front R/H	Front L/H	Rear L or R
65/66...\$27.95 ea.	\$24.50 ea.	\$29.95 ea.
67/68...\$39.95 ea.	\$22.95 ea.	\$29.95 ea.
69/73...\$42.95 ea.	\$27.45 ea.	\$47.00 ea.

E. Splash Shield Kits (w/rubber).

65/66, 65102.....\$39.95 set
67/68, 67102.....\$39.95 set

F. Torque Box.

65/70, 114 (convertible).....\$49.95 ea.
65/70, 117 (hardtop).....\$49.95 ea.

G. Inner Rocker Panel.

65/68, A 112.....\$49.95 ea.
69/73, M 112 A.....\$89.95 ea.

J. Outer Wheel House.

65/66 88113 LH / 99113 RH.....\$49.95 ea.
67/70.....\$54.95 ea.

Inner Wheel House*

65/70 57886 RH / 57887 LH.....\$54.95 ea.

K. Rear Shackles.

65/70, 88103 LH, 99103 RH.....\$29.95 ea.

L. Tail Light Panels.

65/66, 50324.....\$59.95 ea.
67/68, 70324.....\$59.95 ea.
69, 90320.....\$99.95 ea.
70, 320.....\$89.95 ea.
71/73, 30320.....\$99.95 ea.

M. Front Fenders.

65/66.....\$119.95 ea.
67/70.....\$129.95 ea.

N. Outer Door Skins.

65/66.....\$79.95 ea.
67/68.....\$89.95 ea.

P. Lower Rear Quarter Patch.

65/66, 88100 (left).....\$23.50 ea.
65/66, 99100 (right).....\$23.50 ea.
67/68, 88200 (left).....\$27.50 ea.
67/68, 99200 (right).....\$27.50 ea.
69/70, M 300.....\$34.00 ea.
69/70, M 300 A/FB.....\$34.00 ea.
71/73, M 400.....\$39.00 ea.

Inner Lower Rear Quarter Patch*

65/70, A 109.....\$11.95 ea.
71/73, A 409.....\$18.00 ea.

Q. Quarter Panel Skin (repro).

65/68.....\$79.95 ea.
69/73.....\$99.95 ea.

69/70 Fastback Quarter*

C9ZZ-6327840/1 AR (skin).....\$99.95 ea.
C9ZZ-6327840/1 BR (H.D.).....\$169.95 ea.

65/66 Full Quarter Panel*

57846 (hardtop) (right).....\$119.95 ea.
57847 (hardtop) (left).....\$119.95 ea.
67846 (conv.) (right).....\$119.95 ea.
67847 (conv.) (left).....\$119.95 ea.

Trunk Floors*

65/68 61218 RH, \$29.95 65/68 61219 LH, \$29.95
69/70 51218 RH, \$29.95 69/70 51219 LH, \$29.95

R. Frame Rail Complete Front

FULL 124 (2 piece rail) (R or L).....\$134.95 ea.

* Not shown. * PrePay * Shipped Freight Collect
Fender, quarter panels require \$10.00 packing charge

Window Felt Sets
Keep windows from rattling

65/70 Fastback.....\$29.95
65/68 Coupe Conv.....\$39.95
69/70 Coupe.....\$49.95
71/73 All.....\$49.95
Specify year, body style

Complete Floor Special

Incl. 1pr. A 107 fronts, 1pr. A 108 E rears plus 1pr. fire wall patches, 126 PR. FPS 200.....\$229.95

Convertible Floor Special

Incl. 1pr. A 107 fronts, 1pr. A 108 E rears plus 1pr. A 112 inner rocker panels and 1pr. A 114 torque boxes. FPS 300.....\$349.95

65/68 Heater Plenum

Best quality. C5ZZ 18471 BR.....\$22.95
Heater Hose. Orig. style 8 ft.....\$15.95

Tail Light Bezels

65/66 53489.....\$25.90 pr.
67/68 C8ZZ 13489 A.....\$59.70 set

Perfect Fit Radio

AM/FM stereo cassette, 14 watts
65/73 USA 02.....\$139.95
Digital USA 01.....\$219.95
Other Styles Available

Radio Antenna Kit

65/68, C5ZZ 18813 AR.....\$16.95

Floor Mats

A. Tri-Color Running Horse - Blk w/running horse on red, white, & blue striped circle. Set of 4.....\$27.90 set
B. Custom Two-Tone Carpeted Mats Available in black, blue, red or tan. Set of 4.....\$34.95 set
C. Original Pony Mats Black.....\$39.95 set
Color.....\$45.00 set

Export Brace

Black 160521.....\$35.95
Chrome 160522.....\$49.95

Mustang Videos

You'll see hundreds of classic Mustangs, early test drives, vintage TV ads. 30 minutes.
1100 Mustang Round-up '89. 60min. New.....\$19.95
VSR 1 Mustang Video.....\$19.95
VSR 7 Mustangs in Motion.....\$19.95
VSR B The History of Mustangs.....\$14.95
(Repair videos also available)

Car Covers by COVERCRAFT industries inc.

Specify Year & Body Style
Green Drill.....\$72.00
Tan Flannel.....\$99.95
Technolon.....\$99.95
Prices starting at.....

Car Cover Cable Lock

CBLE 100.....\$99.95

65/66 Fog Lamp Kit

Includes housings, bars, bulbs 68390.....\$169.95

Battery Box Kit

65/73 Exact factory repro Includes battery box, hold-down and hardware Specify year.....\$14.00
65/66 C5ZZ 10732 KIT.....\$25.00
67/70 C7ZZ 10732 KIT.....\$17.00

Tri-Y Headers

SAVE! High quality headers add to the performance of any sm. blk. engine. S1MS 9430 R.....\$109.95

P/S Lowering Bracket

Lowering bracket for power steering cylinders. C5ZZ 3A352 R.....\$14.95

HI-PO Exhaust Manifolds.

Add \$100 for chrome. C5ZZ 9430 PR.....\$289.95 pr.

Complete Dual Exhaust Kits

65/68 8 Cyl. C5ZZ 5257 ERK.....\$159.95
(Other Exhaust Kits Available) Save Money!

Door Panels

Specify Year and Color
65/66 Std. \$54.95 pr. 69/70 Std. \$99.95 pr. 65/66 Pony \$115.95 pr.

69/73 Deluxe Door Panels

Not a skin. Specify Year Black or white (less trim).....\$329.95 pr.

69/73 Deluxe Door Panel Skins

Most Colors.....\$249.95 pr.

Door Sill Plates

Please specify year and body style.
65/68 69/70 71/73
\$27.90 pr. \$32.00 pr. \$36.00 pr.

Monte Carlo Bars

Black Chrome
Straight 65602.....\$180.00 65601.....\$299.95
Curved 65603.....\$249.95 65600.....\$299.95

65/73 Leaf Springs

Leaf Springs.....starting at \$139.90 pr.
Specify year and engine size

Rear Shackles

FS 769.....\$15.00 ea.
Urethane Bushings 2019G.....\$4.00 ea.

KYB Gas Shocks

65/73 Set of 4.....\$99.95

Wheel Well Moldings

67/68 791654 Set of 4.....\$74.95
69/70 991654 Set of 4.....\$74.95

Rocker Moldings

65/66 Complete set, inc. hardware.....\$99.50 pr.
67/68 Complete set, inc. hardware.....\$90.00 pr.

See us at these shows!

Jan 19-20 Eastern States, Better Living Center West Springfield, MA
Feb 15-16 Convention Center, Atlantic City, NJ Hartford Civic Center, Hartford CT
April 5-6 Charlotte Motor Speedway Charlotte, NC
April 7 Stafford Motor Speedway, Stafford CT
Call in your order and save 5% by picking it up at the show. We pay the shipping & you save!

Door Handle Assemblies

65/66, 69/70.....524042 \$29.95 pr.
67/68.....724042

Dash Pads

65/66.....\$139.95 69/70.....\$279.95
67/68.....\$174.00 71/73.....\$169.95

Mirrors

65/66 Standard, 576961.....\$26.95
65/66 remote control, 576962.....\$49.95
67/68 remote control, 77696.....\$49.95

65/68 right hand mirror C5ZZ 17636 R.....\$44.95

67/68 right hand mirror CBAZ 17696 AR.....\$57.50

Upholstery

65/68 Standard Bucket Seats.....\$99.95 pr.
Complete Set.....\$149.95
Pony Upholstery \$204.95
Complete Set.....\$204.95
Specify year, body style & color

69/70 Mach 1 Bucket Seats \$159.95 Compl. Set \$239.95

Mustang Wood Steering Wheel

64 1/2, 966 A 65/67, 966 B 68/up, 966 C Complete with mounting kit. Specify Year. \$79.95

65/68 Cowl Vent Repair Kit

With instruc. C5ZZ 18501 R.....\$26.95
Deluxe kit C5ZZ 18501 KIT.....\$39.95

65/73 Front Spoilers

Fiberglass.....\$39.95
Mounting Kit, HH 188.....\$4.00
69/73 Orig. Style, Plastic with mounting hardware.....\$59.95

69/73 Rear Deck Spoilers

Specify year
Original.....\$209.95
Reproduction.....\$129.95

Rear Window Louvers

Easily installed. Specify year and body style. After Market Reproduction.....\$129.95
69/70 Original Style, (as above).....\$329.95

Trunk Mats

Original style. Correct in every way. MCA approved. 68/70 Specify year and body style.....New! \$90.00

Carpet Kit

You get: 1 molded carpet, seat plugs, 1 pr. sill plates, 1 set sill plate screws, seat track spacers, sound proofing. Specify year and body style. 65/68.....New! \$149.95

Molded Carpet

Specify year, body style and color.....\$84.95
Mach 1, w/ inserts.....\$145.00
Fold-down pieces for fastback.....\$15.00
Carpet Underlayment.....\$34.95
All Models.....

*10% shipping, all orders (min. \$2.00). *FREE U.P.S. shipping (Continental U.S. only) on most orders over \$200.00. *Pre-paid mail orders: Please send cashiers check or money order; personal checks must be held 5 days for bank clearance.
Information: (203) 647-1965 TeleFax: (203) 649-1260
Same Day Shipping, Next Day Delivery Available Upon Request!

'91 Marks The Beginning of MCA's 15th Year!

When a small group of people interested in the Ford Mustang got together at Stone Mountain, GA. 15 years ago, few of them could have realized that the organization they were about to form would become one of the largest and best-known collector car clubs in the world.

But from those humble beginnings back in 1976, the Mustang Club of America has grown to tremendous proportions as the popularity of America's original Pony car has soared.

So as we begin 1991, MCA marks its 15th anniversary of serving the needs and interests of Mustang lovers across the United States and in scores of foreign countries.

And we begin our 15th year in great health — our membership has been growing steadily over the past two years, the number of MCA regional groups has increased by almost a dozen in 1990 alone, and we are looking forward to one of the busiest show seasons in our history during the coming 12 months.

Our Show Season, in fact, gets off to an early start this year, with our first MCA sanctioned National set for Disney World in Orlando, FL the first weekend in March.

Bruce Weiss of our Board of Directors says early indications are that the Orlando Mustang National could attract the largest field ever for an MCA event.

That really isn't so surprising when you consider that participants in the Orlando show will receive about \$80 in admission tickets to Disney World attractions!

MCA has grown over the years to become a true family organization, and we expect to see hundreds of our members and their children in Orlando in March for a tremendous Mustang show and a great weekend of family entertainment.

What lies ahead for us during this 15th anniversary year is what I expect to be the best year ever in the history of MCA.

We are having a record number of regional groups express interest in national and grand national shows in 1992, we're seeing a strong membership surge even during the usually slow winter months (check this month's new members list in your magazine to see what I mean!), and we're constantly talking to new groups interested in becoming affiliated with MCA.

MT□MT□MT

Speaking of new regional groups, I had the opportunity during the past few weeks to visit with a lively and enthusiastic group in



CHARLES HAMPTON
MCA President

Savannah, GA, which is in the process of submitting an application for MCA affiliation.

During the course of the past 12 months, we have added 11 or 12 new regional groups to our roster. The Savannah group is simply awaiting the formality of board approval, and National Regional Group Director Horace Wood says he has been in contact with at least three other groups who are in the process of completing applications for MCA membership.

So it appears that we're going to start off 1992 with an even bigger bang than we finished 1990!

MT□MT□MT

Recently I also had the privilege of visiting with the Charlotte, NC MCA Regional Group, and their new president, Bill O'Neal.

This group, which has been with MCA for some time, has recently seen a resurgence in interest and enthusiasm — as have many of our other groups across the country.

Final Call For '92 Grand Nationals!

February 1, 1991 is the final deadline for applications from MCA Regional Group affiliates interested in hosting the 1992 Grand National. All clubs interested in being considered as the host group for the 1992 Grand National must have their applications in to MCA Headquarters by the Feb. 1 deadline.

Deadlines for groups interested in hosting MCA-sanctioned National Shows is 1992 is March 1, 1991.

The deadlines for National and Grand National Shows were changed in 1990 at the request of regional groups who are finding it necessary to book show sites as much as 12 months in advance.

The MCA Board of Directors will award the 1992 Grand National at its March, 1991 meeting. MCA-sanctioned National Shows

will be awarded at the board's April, 1991 meeting.

In an extended session with Bill and his members, I was able to answer a great many questions about MCA and to explain to these loyal Mustang lovers how the national organization and local groups can work together to make our hobby more interesting and exciting for everyone.

I expect we are going to be seeing great things from the Charlotte group in the weeks and months to come and I want to thank Bill and his members for inviting me to visit with them.

MT□MT□MT

As president of MCA, I want to extend a personal invitation to all of our members — from coast to coast and worldwide — to join your officers and board members January 26 in Marietta, GA for the 1991 Annual Meeting and Installation New Officers.

The banquet will be held at Baby Doe's Restaurant on Powers Ferry Road in Marietta, GA. The restaurant — which is a sight to behold! — is convenient to both I-75 and I-285.

The evening will begin at 7 p.m. and we encourage all MCA members who can to attend.

Advance reservations are required and the cost is \$25 per person. You can get your tickets by writing to MCA Annual Meeting, P.O. Box 447, Lithonia, GA 30058-0447. But hurry. All reservations and prepayments must be in by January 15.

Make your plans now to join us for this great event and help your national officers and board members kick off MCA's 15th Anniversary Year!

Grand Nationals are awarded one month in advance of national shows to permit regional groups who are not approved for Grand National events to resubmit their applications for National Shows, if they so desire.

MCA President Charles Hampton urges groups interested in applying for MCA-sanctioned events in 1992 to write today for forms.

"The interest among our regional groups in hosting MCA-sanctioned events is at an all time high. We urge any group interested in hosting a National or Grand National Show to mail their applications immediately as the deadlines are rapidly approaching," Hampton said.

The Mustang Times/January, 1991

OHIO & FLORIDA

MUSTANG

CONNECTION



NEW PARTS • REPRODUCTION PARTS • USED PARTS

1964 - 1973 Mustangs

- **BODY REPAIR & PAINTING**
- **FLOOR PAN & CONVERTIBLE FRAME REPAIR**
- **ENGINE CLEAN-UP & DETAILING**
- **UPHOLSTERY & HEADLINER INSTALLATION**
- **FULL RESTORATION FACILITIES**
- **INSURANCE APPRAISALS**

**2 LOCATIONS
TO SERVE YOU BETTER**

Ohio Mustang Connection
9140 Hazelton-Etna Rd. (Rt. 310)
Pataskala, Ohio 43062
(614) 927-6078

Florida Mustang Connection
7817 Commerce St.
Riverview, Florida 33569
(813) 677-3196

Our Sympathies To These MCA Members...

After a couple of trips around the show circuit in the Mustang hobby, you quickly begin to regard the many friends you meet as part of your extended family. That's why we feel the losses of our fellow MCA members deeply.

And, as always seems to be the case, the holiday season — which is such a joy for most of us — always brings its share of tragedy as well.

I know all our members will join me in extending sympathy to the family of Bill and Barbara Koivu in the loss of Bill's step-father, Stan Bentley, of Lansing, MI, just before the Thanksgiving Holiday.

Bill and Barbara are both long-time members of the MCA's Board of Directors and Bill has served as our national treasurer since 1978.

After 13 years as treasurer, Bill is an MCA institution. He is also the person most of you talk to when you call the MCA office in Lithonia.

He fields literally thousands of calls each year — many from prospective new members, many others from regional groups and members who have questions or suggestions about our organization.

And, if that wasn't enough, Bill and Barbara are the two people who make sure you get your *Mustang Times* each month. They handle the complex task of keeping up with our thousands of members and mailing each issue of the magazine.

We all value the Koivus and their dedication to MCA and offer them our prayers.

MT□MT□MT

We also wish to extend our sympathy to Charlie Barrett of Marietta, GA who lost his wife, Nancy, to ALS before Thanksgiving.

Charlie has been an MCA member for many years. He has two Mustangs of his own and his son is a Pony lover as well.

Mrs. Barrett was 54.

Our thoughts are with Charlie and his family in their time of sorrow.

MT□MT□MT

A tragedy of another sort befell Ken Dutton right after the Thanksgiving Holiday.

Ken's Mustang business on College Avenue in Decatur, GA burned to the ground — resulting in the loss of countless parts and several classic cars.

Ken is a charter member of MCA and has been a Mustang enthusiast ever since the first Pony rolled off the line in Detroit. His storehouse of parts was a tremendous loss



JACK YEAGER
Publisher

to him personally and to all of us who love our Mustangs.

We sincerely regret Ken's loss and hope he can find a way to rebuild his business as quickly as possible.

MT□MT□MT

So many MCA members know one another from years of visiting and socializing on the show circuit, and that's why we at *The Mustang Times* consider it important that you share any information you have about your fellow members with us.

We think it is important to make note of

the losses suffered by our members, just as we consider it essential to keep Mustangers informed about show results, outstanding cars, and news related to Mustangs and the classic car hobby in general.

And we depend upon you — our readers — to help us get all this information in to your magazine.

So if you have an item to contribute about any of your fellow regional group members or other MCA members you know personally, please drop us a line. We want to include as many of you as possible in your monthly magazine.

We're especially interested in any of our members or their loved ones who might be serving our country in Saudia Arabia during these tense and trying times.

If you know the name of a Mustanger participating in Operation Desert Shield, please let us know. And include their address so some of our other members can drop them a line and let them know how much those of us back home appreciate what they are doing for their country.

I hope to be hearing from you soon.

—Jack Yeager

MCA's 1991 ANNUAL MEETING and INSTALLATION OF OFFICERS WILL BE HELD JANUARY 26th

All Current MCA Members Are Invited!

Make your plans now to attend the 1991 MCA Annual Dinner Meeting and Installation of Officers January 26 at Baby Doe's Matchless Mine in Marietta, GA.

The dinner meeting will begin at 7 p.m. at the restaurant, located at 2239 Powers Ferry Road, Marietta, GA. The restaurant is convenient to both I-75 and I-285.

Reservations and pre-payment are required. Reservations and checks (\$25.00 per person) must be received by MCA no later than January 15, 1991.

Mail checks to: MCA Annual Meeting, P.O. Box 447, Lithonia, GA 30058-0447.

Reader's 1965 Mustang Wins An AACA Trophy

Editor:

I am very proud to be a member of The Mustang Club of America and I look forward to reading *The Mustang Times* each month.

I am also a member of the Antique Automobile Club of America, which is headquartered in Hershey, PA.

On October 13th, my 1965 Ford Mustang coupe was entered in the Fall AACA National Show and I am very proud that my coupe received a second junior trophy award in this show.

My Mustang was the first to be registered as an antique in the state of Pennsylvania. It was registered very early in January of 1990. I am hoping to show my car in shows again in 1991.

**Carl H. Ney, Jr.
Ashland, PA**

Desert Shield Reservist Spots GT In Saudia Arabia

Editor:

I have always been intrigued by reading letters about Mustang owners in distant and unlikely places. Now I am writing as one.

I am an Army Reservist serving in Saudi Arabia. My first week here I spotted a 1989 GT, a beautiful dark red one. I'll try and get a picture of it with its Saudi Arabian license plate if I see it again.

The smooth, uncrowded highways, combined with the 120 KPH speed limit, would make this ideal Mustang territory. The 38-cent-per-gallon gasoline wouldn't hurt, either.

I will have to keep my eyes open for any vintage Mustangs over here.

I hope to be back just in time for the Pensacola Show in 1991. Maybe I will see you there.

**Cpt. Roger Roseman
321st MMC
Operation Desert Shield
APO NY, NY 09616**

Indy Pace Car Registry Now Being Organized

Editor:

For the past few years, people who have been trying to restore Indianapolis Pace Car Mustangs have run into a brick wall when it comes to locating parts and information. Now a registry is being formed to help those individuals.

Anyone wishing to find out more about this registry should send a stamped, self-

The Mustang Times/January, 1991

addressed envelope to Indy Pace Car Registry of 1979 Mustangs, P.O. Box 261251, Lakewood, CO 80226.

In return, that person will receive the necessary paperwork to complete. For a nominal fee, the paperwork will be processed and the Mustang owner will receive a lapel pin to show their association with the registry.

If there is enough response, a quarterly newsletter will be published with information and a parts locator service.

We are looking forward to the participation of MCA members.

**Wilhelm Troussemet
MCA Membership No. 20369**

More Comments Relating To Rumors Of Pre-71 Ban

Editor:

The talk about federal legislation banning the use of pre-1971 vehicles from our highways is completely stupid. What is the government hoping to accomplish? I can name many new cars that burn more oil than my 1964½ Mustang.

I am a 17-year-old high school student and cannot possibly afford a new car. I presently own three Mustangs and I don't care if they do pass the law, I will drive my cars anyway.

I have sent a letter to many of the elected representatives of Georgia. I hope I don't upset anyone with this opinion, but I feel very strongly about this, as I am sure many other Ford (as well as Chevy, Pontiac and other) car owners do.

**Michael Paul St. Germain
Member Number 22025
Snellville, GA**

(Editor's Note: As MCA Board Member Bob Deale explained in a letter published in the December issue of The Mustang Times, there is no legislation currently pending in Congress regarding the banning of pre-1971 vehicles from the highways. We certainly appreciate your concern in this matter, but apparently there has been a great deal of misinformation disseminated on this issue.)

MCA Member Praises Pony Carburetor Products

Editor:

I want to thank Jon Enyert and all the people from Pony Carburetors. I ordered a carburetor from them for my 1967 GTA coupe and their service is excellent.

What is most important is that their craftsmanship is superb. Now my pony is run-

ning like new. This isn't a sales pitch for them because their products speak for themselves. Thanks guys!

**SSG William A. Green IV
HHC 32nd Signal BN
APO, NY 09757
MCA Member No. 22269**

Reader Seeking Help Locating 14" Radial Tires

Editor:

I wonder if any of my fellow members out there can help me with a tire problem.

The MCA Judging Rules call for non-P metric tires, but will allow radial tires for my 1969 Mustang. I have used radials exclusively for the past 10 years and far prefer them to the old bias ply jobs with respect to both gas mileage and handling. Since mine is a street driven, concours class car, I would like to find some new radials, something like E-70 or F-70, but they seem to be non-existent. I have checked with three different dealers who handle antique tires and all they can supply are polyester bias ply tires.

Does anyone know if there are any manufacturers making non-P metric radials in 14" diameter that would be correct for my Mustang? If they are not available, maybe the rules committee could consider waiving this item as I really believe that street driven cars should be rolling on radials these days.

**William W. Gullett
Vero Beach, FL
MCA Member No. 212**

(Editor's Note: Two things you might try: you might have some luck searching for the tires you need at a junk yard, or, better yet, try some tire dealers in small towns who have been in business for years. Sometimes they have outdated stock that has been put back or warehoused for some time. Failing those two suggestions, we're printing your letter in hopes that some other MCA member might have a better solution to your problem.)

Your Letters, Comments Are Important To Us

Each month *The Mustang Times* prints at least one full page of comments and letters from our readers across the U.S. and around the world.

We encourage MCA members to take advantage of this forum to express their views about the Mustang hobby, to ask questions, to seek help, or to share information with other Mustang enthusiasts.

Address your letters to: Reader's Forum, *The Mustang Times*, P.O. Box 447, Lithonia, GA 30058.

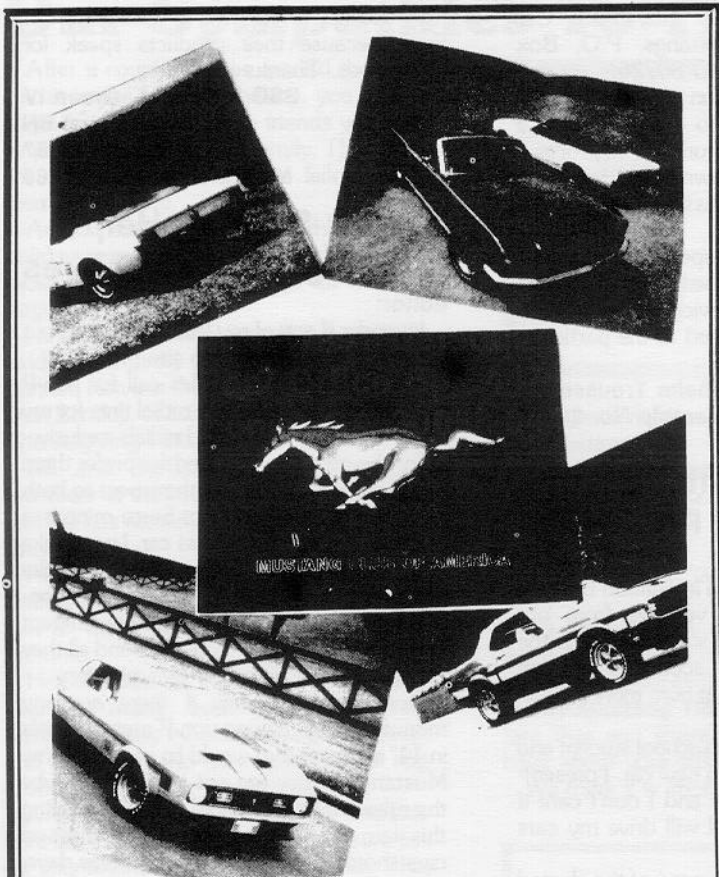

Hot Off The Presses! MCA's Official 1991 Calendar!

Be among the first Mustangers in the nation to get your own Official 1991 MCA Calendar — a full-color presentation of some of the best Mustang Muscle in the world.

The 1991 edition features 12 outstanding Pony cars from throughout the United States — an impressive assortment of convertibles, coupes, and hardtops representing the entire 26 year history of the Mustang.

This rare collector's item is a must for MCA members and it makes the perfect Christmas gift for any Pony lover. Send \$7.00 plus \$1.50 for postage and handling to:

MCA 1991 Calendar
Post Office Box 447
Lithonia, GA 30058-0447

MCA '91 Show Season To Get An Early Start

Mustangers eager for another MCA show season will have an opportunity to start '91 early, with the first National event set for March 2-3.

The Florida Regional Mustang Club will host the first MCA show of 1991 at Walt Disney Village in Orlando, FL that weekend.

Bruce Weiss, a member of the MCA Board of Directors and the Florida Regional Mustang Club, says interest is running high for the season kick-off and the Orlando show could very well be the largest show in MCA history by the time registration closes.

All show entrants at Orlando will receive two free passes to either the Magic Kingdom, Epcot, or MGM Studios, plus two free tickets to Pleasure Island.

MCA members desiring information on the Orlando MCA National can call Steve Ames at (813) 962-2936 or Weiss at (407) 259-9089 days or (407) 724-0875 evenings.

Registration information for the Disney World show also appears on Page 19 of this issue of **The Mustang Times**.

The Gulf Coast Regional Mustang Club will host the second 1991 MCA National during the final weekend in March at University Mall in Pensacola, FL.

The Gulf Coast group, which has always attracted large fields of competitors, also anticipates record crowds for its MCA-sanctioned national.

For information on the 1991 Gulf Coast Regional MCA National Mustang Show, contact Donnie Carlisle at (904) 455-6588 or Rodney (Shorty) Brown at (205) 947-4180.

A registration form for the March 29-31 Pensacola MCA show appears on Page 14 of this issue of **The Mustang Times**.

Other national shows planned for 1991 include an April 17 event hosted by the Music City Mustang Club of Nashville, TN. For information on that event, contact Frank Davis, President, Music City Mustang Club, 1028 Dozier Place, Nashville, TN 37216.

Registration forms for the Nashville MCA National will appear in the February issue of **The Mustang Times**.

The Central Illinois Mustangers will host an MCA National May 31-June 1 in Springfield, IL.

The Georgia Regional Mustang Club will host an MCA National at John Bleakley Ford on I-20 in Lithia Springs, GA, just west of Atlanta, July 12-14.

The final event of the 1991 season — MCA's 1991 Grand National — will be held in Kingsport, TN August 16-18. That event will be hosted by the First Tennessee Regional Group and will be held outdoors at the Kingsport Convention Center.



VINTAGE MUSTANGS

"Specializing in Small Block Fords"

LEE WILMOT
404-378-2817

2734 E. Ponce de Leon
Decatur, Georgia 30030

NEW ENGLAND MUSTANG SUPPLY



1830 Barnum Ave. • Bridgeport, CT 06610
(203) 333-7454 / Order Toll Free 1-800-242-2314

FREE UPS shipping on orders over \$200,
\$5 charge otherwise. COD \$4 additional (see our policy)

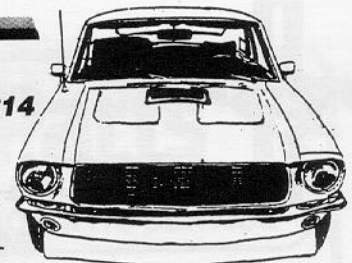

SUSPENSION

'64 1/2-'73

Coil Springs

Stock/GT

..... \$69.95 pr.

Lowered Competition

..... \$79.95 pr.

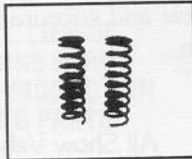

FRONT & REAR HANDLING SPRING KITS

'79-'89 M-5300-B "Sports" Handling

79-'89 M-5300-C "Super Sports" Handling

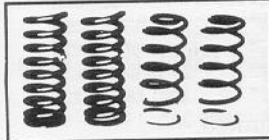

M-5300-C KIT
Shown Here
M-5300-B
M-5300-C
set of four
\$135

'64 1/2-'73 UPPER
CONTROL ARMS
\$99.95 Each

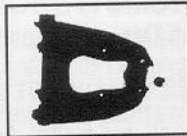

'79-'89 MOTORSPORT

M-3075-A Front Lower
Control Arm Kit

\$126 pr

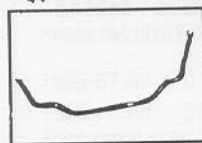

SWAY BAR KITS

'65-'73 Competition

Front or Rear

\$89.95 each

(Complete with hardware
& urethane bushings)

'79-'89 MOTORSPORT

M-5627-A
STABILIZER
BAR KIT

Front & Rear
\$144 pr

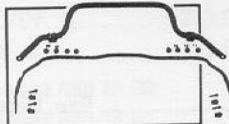

Kit includes beefy stabilizer bars, (front 1.31" dia. rear 0.79" dia.), teflon-lined insulators, urethane end-link bushings, necessary fasteners and instructions.

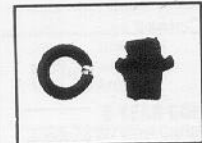

COIL SPRING LOWER MOUNTING ASSEMBLY

\$36.50 each

Insulators... \$3.00 each

'64 1/2-'73 REAR LEAF SPRINGS

\$150 pair / Heavy-Duty \$169.95 pair

U-Bolts \$3.50 each

Shackle Kit... \$15.00 each

LOWER CONTROL ARMS

'64 1/2-'73 \$39.95

TIE RODS...\$19.95 each

'65-'66 / 6 cyl. P.S. \$42.00 each

KYB GAS SHOCKS

'64 1/2-'73 Set of Four \$109.95

SUSPENSION & HANDLING KITS — 64 1/2-'73

* KIT #1

- 1 pr. Upper Ball Joints
- 1 pr. Lower Control Arms
- 1 pr. Outer Tie Rods
- 1 pr. Rebound Bumpers
- 1 pr. Strut Rod Bushings
- 1 pr. Sway Bar Bushings
- 1 pr. End Links

..... \$189.95

* 65-66 6-Cylinder with P/S \$229.95

* KIT #2

- 1 pr. Upper Control Arms
- 1 pr. Lower Control Arms
- 1 pr. Outer Tie Rods
- 1 pr. Inner Tie Rods
- 1 Grease Fitting Kit
- 1 Idler Arm
- 1 pr. Strut Rod Bushing Kit
- 1 pr. Sway Bar Bushing Kit
- 1 pr. End Links
- 1 pr. Tie Rod Adjusting Sleeves

..... \$449.95

* 65-66 6-Cylinder with P/S \$549.95

* KIT #3

- 1 pr. Rear Leaf Springs
- 1 pr. Front Coil Springs
- 4 KYB Gas Shocks
- 1 pr. Spring Seats
- 1 pr. Spring Insulators
- 1 set U-Bolts, Nuts & Bolts

..... \$399.95

* Add \$10 for 1" Lowered Coil Springs

* Add \$20 for H.D. Rear Leaf Springs
Note: Our rear leaf springs are not "one size fits all". We sell only springs for your specific application!

* KIT #4

DELUXE SUSPENSION AND HANDLING KIT

Includes all items in kit #2 & #3 plus front 1" and rear 3/4" sway bars with attaching hardware \$999.95

* Add \$10 for 1" Lowered Front Coil Springs

* Add \$20 for H.D. Rear Leaf Springs

* Add \$100 for 65-66 6-Cylinder with P/S

VALVE COVERS

351-C BLACK
OR POLISHED
\$59.95 Pair

COBRA

(Small Block)

Dress-Up Kit

\$139.95 Kit

Includes: Pair Cobra valve covers, Hi-Po air cleaner, chrome dipstick tube, chrome radiator cap, chrome oil cap.

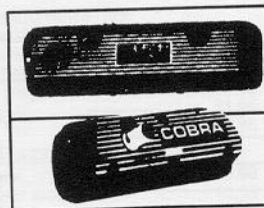

COBRA OVAL AIR CLEANER ASSEMBLY \$79.95

DUAL POINT DISTRIBUTOR CONVERSION KIT \$19.95



UPHOLSTERY & SOFT TRIM

'65-68 Upholstery Package

Special \$299.95

- 1 Full Set Standard Upholstery (Fr. Buckets & Rear Seat)
- 1 80/20 Molded Carpet
- 1 Pr. Standard Door Panels
- 2 Cans Interior Spray Paint
- Upholstery installation Kit



INTERIOR

65-69 Standard Upholstery w/Buckets and

Rear Seat	set 149.95
65-66 Pony Upholstery	set 199.95
69-70 Mach 1	set 249.95
71-73 Mach 1	set 289.95
69-73 Grande	set 350.00
71-73 Mach 1 white w/gray & white Comfortweave Very Limited Production, Prices Starting At	set 399.95
70-73 Standard Upholstery Front & Rear	185.00
65-68 Standard Door Panels	pr. 55.00
65-66 Dash Pad	159.95
67-68 Dash Pad	189.95
65-66 Arm Rest Base	ea. 5.00
65-66 Arm Rest Pad	ea. 7.50
65-73 Molded Carpet	set 89.95
65-73 Headliner	ea. 22.50
65-68 Convertible Quarter Trim Upholstery	pr. 25.00

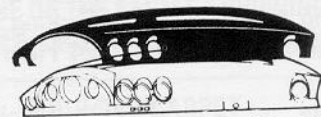

Your Answer to Cracked Dashes

Mustang Applications:

'65, '69-'73, '79-85	\$79.95
'74-78	\$9.95

STRIPE KITS — NEW!!!

73 Argent Mach 1 Kits	\$99.95
71-72 Argent Center Body Stripe	99.95
76-77 Cobra II 9 Piece Kit	150.00
78 King Cobra Kit	199.00
79-80 Cobra Hood Snake	\$100.00

MUSTANG WOOD STEERING WHEEL

Complete with mounting kit.

\$79.95



CHROME

65-73 6 Cylinder Valve Cover	\$49.95
65-66 Grille Molding	ea. 19.95
67-68 Grille Molding	ea. 12.50
65-66 Day/Nite Mirror	29.95
65-66 Back-Up Lights	ea. 29.95
65-66 Convertible Survivor Brackets	ea. 49.95
65-70 Export Brace	ea. 48.50
67-68 Remote Mirror	ea. 49.95
65-66 Taillight Bezels	pr. 25.00
67-68 Taillight Bezels (6)	set 59.95
65-70 Bumpers... ea 79.95, or	pr. 150.00
65-66 Bumper Guards	pr. 30.00
65-68 Hood Molding	ea. 9.95
65-68 Scuff Plates	ea. 12.95
69-70 Scuff Plates	ea. 19.95
71-73 Scuff Plates	ea. 19.95
65-66 Nameplate "Mustang"	ea. 6.50
65-66 Door Handle Kits	pr. 29.95
67-68 Door Handle Kits	pr. 29.95
69-70 Door Handle Kits	pr. 29.95
65-66 Hood Letters	set 7.50
65 Quarter Panel Ornament	pr. 29.50
66 Quarter Panel Ornament	pr. 35.00
65-73 Hi-Po Air Cleaner	ea. 19.95
65-66 Exhaust Bezel	pr. 25.00
65-66 Rocker Moldings	pr. 85.00

FLOOR PANS

65-70 Full Length ea. 80.00
65-70 Long Front ea. 39.50
65-70 Rear ea. 39.50
or Set 149.95



'64-'73 Mustang Catalog \$3.00 / '74-'89 Mustang Catalog \$5.00 / '90 Sportwear & Accessory Catalog \$2.00

SHIPPING POLICY: We pay shipping on normal UPS orders over \$200. We reserve the right to charge additional shipping on oversize or extra-heavy packages. Any shipment sent to a post office box or APO, add 20% shipping, minimum \$5. Items too large for UPS are sent via truck freight collect. This shipment policy good in the continental U.S. only. Prices subject to change without notice.





12th Annual Gulf Coast Regional MCA National Mustang Show



March 29-31, 1991 — Pensacola, FL

- March 29 8 AM to 5 PM: Vendors set up. Tech Inspection available and encouraged.
6 PM to 10 PM: Hospitality Party, Fish Fry, Holiday Inn.
- March 30 7 AM to 12 NOON: Tech inspection and parking.
12 NOON to 5 PM: Judging All Show Vehicles must remain in place until 12 Noon March 31.
6:30 PM: Entertainment
- March 31 8 AM to 12 NOON: Cars Displayed. NOTE: Call Motels directly. Do NOT call 800 Reservation Number.
12 NOON: Awards Presentation.
- Show Site Directly in front of University Square Mall. Exit from I-10 (Exit 5) and follow show signs.
- Vendors Please Pre-Register by March 20. Notification of space will be confirmed.
- Raffle Car 1966 Yellow Mustang Convertible. To Benefit Ronald McDonald House, Shrine Hospital Fund for Children, Sacred Heart Children's Hospital.
- Parking & Security Parking for trailers and motor homes. (No hook-ups). Look for trailer signs.
24 Hour security during show days.
- On Site Motels Mall Holiday Inn (on-site) (904) 474-0100
Hampton Inn (904) 477-3333
Reservation Deadline March 10. Specify Mustang Show.
- Special Interest Ford powered 1960-73 cars only. No trucks.
No umbrellas or aerosol cans on show grounds.

(PLEASE PRINT)

REGISTRATION

Name _____ MCA # _____ Exp. Date: _____

Address _____ City _____ State/Zip _____

Car #1: Year _____ Body Style _____ Serial # _____ Color _____

Car #2: Year _____ Body Style _____ Serial # _____ Color _____

Car Registration MCA (\$15 each) _____

Car Registration Non-MCA (\$25 each) _____

Vendor Space (10X20) (\$25 each) _____

Pony Corral (\$10 each) _____

Raffle Tickets (\$1 each) _____

or 6/\$5.00 _____

Total Enclosed _____

Car Classes

Concours (driven) _____

Concours (trailerd) _____

Street _____

Modified _____

Unrestored _____

Thoroughbred _____

Retired _____

Late Model (1974-up) _____

Club Affiliation, if any _____

Car #1 _____

Car #2 _____

Number Attending Hospitality Party _____

Mail Payment To:

Gulf Coast Regional MCA
P.O. Box 10126
Pensacola, FL 32524

For Additional Information:

Donnie Carlisle (904) 455-6588
Rodney (Shorty) Brown (205) 947-4180
Sue Carlisle (904) 455-6588 (Registration)

I agree to abide by all rules of the show and understand that I am responsible for my car and merchandise. I agree to release from all liability, The Mustang Club of America, Gulf Coast Region Group, Hampton & Holiday Inns, University Mall, Merchants Assn. and Corporate Property Investors for any damage, injury, lost or stolen merchandise from this event.

Signature _____ Date _____ Phone _____

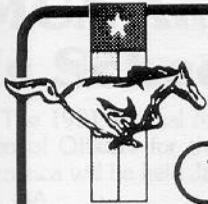

Texas Mustang Parts

THE COMPANY THAT GUARANTEES YOUR SATISFACTION & ITS SERVICE

WE CARRY A FULL LINE OF OVER 4000 GENUINE FORD AND QUALITY REPRODUCTION 1965-73 MUSTANG PARTS IN STOCK

- *Upholstery
- *All Interior Items
- *Under Hood Items
- *Clutch & Brake
- *Electrical
- *Weatherstrip
- *Exterior Items
- *Differential Items
- *Convertible Tops
- *AC Parts
- *Windshields
- *Audio
- *Suspension
- *Sheetmetal
- *Decals
- *Wiring
- *Literature
- *Moulding
- *Bumpers



1965-1973 Classic Mustang Parts and Accessories

PLUS MANY MORE ITEMS!

Call our **CATALOG REQUEST NUMBER 1-817-662-2793** or write for your **NEW FREE CATALOG** of 146 pages and over 675 pictures of **GENUINE FORD** and **TOP QUALITY REPRODUCTION PARTS** along with illustrations, code tables, & paint codes for your 1965-73 Mustang. **HAS YOUR MAILING ADDRESS CHANGED?** Please notify us so you will continue to receive our Catalog plus any special announcements.

Along with our guaranteed satisfaction policy, **TEXAS MUSTANG PARTS** provides the following services:

- * **FREE** Catalog
- * **FREE** Toll Calls for orders
- * **FREE SHIPPING** on orders over \$150 in continental USA if UPS acceptable
- * **LARGE PURCHASE DISCOUNTS**
- * **SAME DAY SHIPPING** on most orders, all within 36 hours or we will notify you
- * **GENUINE FORD & TOP QUALITY REPRODUCTION PARTS** separated by part numbers
- * **MONEY BACK GUARANTEE** on unused merchandise purchased from us.

Combine the above services with our **quality merchandise, low prices, and quick courteous service** and you will find out why **"WE ARE ONE OF THE FASTEST GROWING MUSTANG DEALERS IN THE USA."**

NEW WINDSHIELDS Shaded Top with Tinted Bottom *FREE DELIVERY IN CONTINENTAL USA*

1965-67 All	140.00
1968 All	140.00
1969/70 Cp/Cv	180.00
1969/70 Fb	200.00
1971-73 Cp/Cv	200.00
1971-73 Fb	230.00

Alaska Add 20.00
Hawaii Add 53.00

FINEST AUTHENTIC MUSTANG UPHOLSTERY AVAILABLE

1965-69 STANDARD SETS	
Two Buckets & Rear	149.95
Two Buckets	105.95
1970-73 STANDARD SETS	
Two Buckets & Rear	189.95
Two Buckets	125.95
1965/66 DELUXE PONY SETS	
Two Buckets & Rear	199.95
Two Buckets	129.95
1969-73 DELUXE/MACH1/SHELBY'S	
Two Buckets & Rear	249.95
Two Buckets	165.95

MOULDED CARPET

The most original moulded carpet available with the correct heel & toe plates, padding, & serge or vinyl bound edges.

80/20 Rayon/Nylon Blend	
1965-68	88.00
1965-68 Folddown	15.00
100% Nylon Blend	
1969-73	88.00
1969-73 Folddown	15.00
MACH I	
1969/70	160.00
1971-73 Pony Insert	160.00
1969-73 Folddown	15.00

ARM REST PADS & BASES

1965/66 Arm Rest Pad	ea. 9.50
1965/66 Chrome Base	ea. 7.50
1967 Arm Rest	ea. 21.95
1968 Arm Rest	ea. 28.95
1969/70 Arm Rest	ea. 33.95
1971-73 Arm Rest	ea. 26.95

6 YEAR CONVERTIBLE TOPS

1965-73 W/Vinyl Curtain Black or White	134.95
1965-73 W/Glass Curtain Black or White	224.95
1965-70 Original Type Webb Pads	4 Pc. 49.50

WEATHERSTRIP

1965-68 Conv Top Kit	5-pc. kit 100.00
1965/66 Door to Body	pr. 21.95
1967/68 Door to Body	pr. 26.95
1969/70 Door to Body	pr. 44.95
1965-68 Cp Roof Rail	pr. 31.95
1965-68 FB Roof Rail	pr. 52.95

GLASS GASKETS

1965-68 Windshield	25.95
1965-68 Coupe Rear Glass	25.95
1965/66 FB Rear Glass	25.95
1967/68 FB Rear Glass	34.95
1969-73 FB Rear Glass	39.95
1969-73 Coupe Rear Glass	39.95

STANDARD DOOR PANELS

New panels in all colors from our upholstery manufacturer. Exact match in grain & color.

1965-69	pr. 64.00
1970	pr. 79.00
1971-73	pr. 84.00

OTHER DOOR PANELS

1965/66 Pony WO/Chrome	pr. 134.95
1967 Deluxe WO/Chrome	pr. 179.95
1968 Deluxe Woodgrain	pr. 135.00

HEAVY DUTY KICK PANELS

1965-68 CP/CV/FB	pr. 22.95
------------------------	-----------

FOR 1964½ MUSTANGS

NEW STEERING WHEEL

call for details

Black	158.20
Colors	203.20

ORDER TOLL FREE IN TEXAS AND U.S.A.
1-800-527-1588

CATALOG REQUEST NUMBER
1-817-662-2793

FAX # 1-817-662-0455
INFORMATION: 1-817-662-2893

Texas Mustang Parts

Rt. 6, Box 996A Waco, Texas 76706

STORE HOURS:

Mon.-Fri. 8-5:30, Sat. 8-12 Central Time

We Accept Visa-MasterCard-COD-Money Order
Prices subject to change without prior notice
Texas Residents Add 6½% Sales Tax.

COMPARE OUR PRICES on the **BEST QUALITY PARTS** available to other dealer's prices and add the **FREIGHT** and **TELEPHONE** charges to their total price and you will find doing business with **TEXAS MUSTANG PARTS** will usually cost less. Plus our **LARGE PURCHASE DISCOUNT PLAN** will save you even more money.

MUSTANG COLLISION REPAIR SPECIALIST

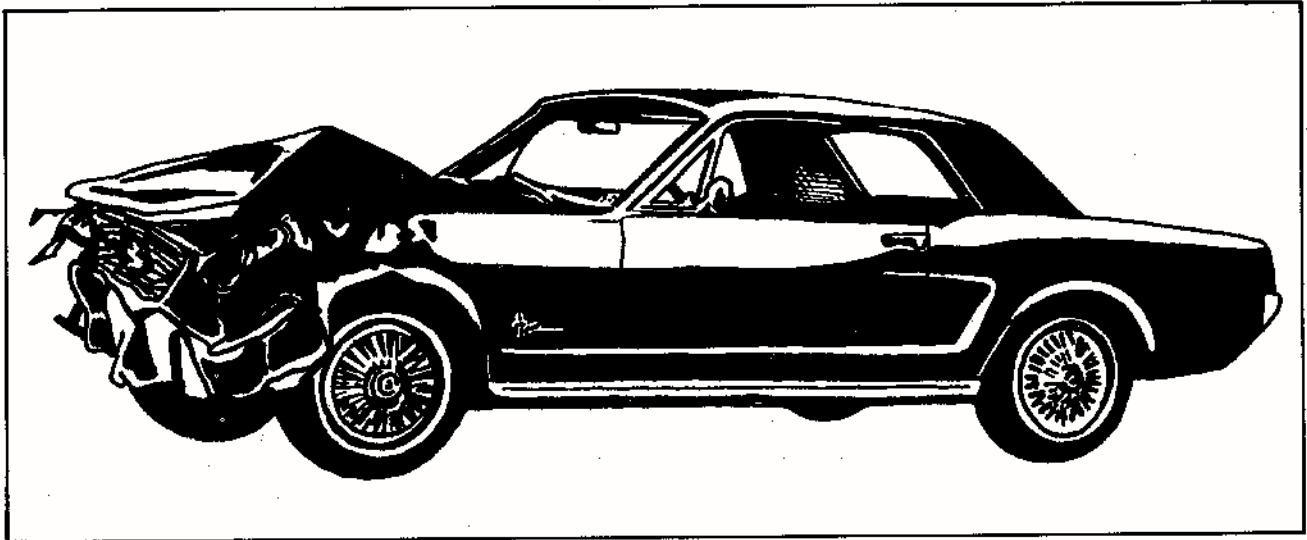

- Insurance Claims
- Show Quality Paint Our Specialty
- Frame Repair
- Sheet Metal Replacement
- Expert Paint Matching
- Towing

Custom Coachworks

Over 10 years experience dealing with Insurance Claims on Classic Mustangs.

ATLANTA, GA

404-422-3065

SOUTHEAST

Custom Coach Works
2960 Cobb Parkway
Kennesaw, GA 30144
404-422-3065

CHARTER MEMBER

CRA
Collision Repair Association

MCA Annual Installation Dinner Is Scheduled For January 26th

The 1991 Annual Meeting and Installation of Officers for the Mustang Club of America will be held January 26 in Marietta, GA.

The date for the annual dinner meeting was set by the MCA Board of Directors at its November meeting.

Newly elected MCA National Officers and Board Members will be officially installed at the dinner.

The meeting will begin at 7 p.m. and will be held at Baby Doe's Matchless Mine, 2239 Powers Ferry Road in Marietta, GA. The telephone number is (404) 955-3637.

The restaurant is convenient to both I-75 and I-285.

The installation banquet is open to all MCA members.

Reservations must be made by January 15 and payment (\$25 per person) must be received by that date.

Send checks and reservation requests to MCA Annual Meeting, P.O. Box 447, Lithonia, GA 30058.

Modified Rules Changes

MCA members interested in the upcoming year's rules changes in the modified classes are invited to express their comments.

All responses received by January 28 will be considered in the rules revisions. These changes will be included in a new rule book.

Write to: Modified Rules Changes, C/O Jeff Speegle, 1223 Huntington, Manteca, CA 95336.

Pony Carburetors Show Quality Rebuilt Carburetors

- ★ Competitive Pricing
- ★ We Rebuild Yours Or You Buy Ours
- ★ One And Two Barrel Specialists
- ★ Hi-Po Source

**Simple Do It Yourself 6 Cylinder Performance Kits
\$18.00 Plus \$2.00 Shipping**

- ✓ Improves Performance, Drivability And Power
- ✓ Corrects Hesitation, Flat Spots, Morning Start, Hot Start Stall
- ✓ Included: Parts, Complete Explanation, Instructions, Diagrams
- ✓ State Engine Size, Transmission Type, With Or Without Air

Reproduction Carburetor Tags \$10.00 (Includes Shipping)

- FoMoCo And Autolite Series
- Order By Application Or Your Tag Number
- State Engine Size, Transmission Type, With Or Without Air Production Date Of Car Or Carburetor
- Production Date And Design Changes Included On Tags

Pony Carburetors
P.O. Box 420 74 Lincklaen Street
Cazenovia, New York 13035
(315) 655-4466

**NOW ORDER TOLL-FREE!
(800) 882-7MPC**
For Info & Answers Call:
(214) 262-8171



Arm Rest Deal 2/85-66	1965-73 Decals
Bases 2/85-66	1965-73 Carpet
Pads \$23.00	Headliners \$25/ea
Trunk Deal! Trunk Mats Tire Cover & Jack Pack! \$25.00	Gadget Bag \$11/ea
	Trunk Mats \$17/ea
	1965-68 Door Panels
	Weatherstripping Kits
	Owner's Manuals \$5/ea
	1965-73 Upholstery Kits
	Jack Pack Plaid \$4.00/ea
	1965-73 Rechromed Bumpers
	Tire Cover Plaid \$8.00/ea
	Wiring Diagrams \$4.95/ea
	1965-66 Chrome Export Brace \$57.50
	Black Export Brace \$45.70
	1965-73 Heater Cores \$30.00
	1965-66 Armrest Bases \$7.50/ea
	1965-66 Armrest Bases \$5.00/ea
	1971-72 Pop Open Gas Cap \$48.15
	1965-73 Rear Leaf Springs \$79.00/ea
	1965-66 Window Regulators \$29.00/ea
	1965-68 Kick Panels \$27.00 pr
	Battery Tray 1965-66 \$10.75
	1967-68 \$15.00
	1971-73 \$9.90
	Convertible Top Repair Manual \$5.95
	Shop Manual 1965-68 \$29.00
	Floor Pans, Front 1965-70 \$36.95
	Rear 1965-70 \$32.95
	RH Battery Apron 1965-66 \$30.95
	1967-68 \$37.40
	LH Apron 1965-68 \$30.00
	Instrument Cluster Bezel
	1965 Black Camera Case \$37.50
	1966 Black Camera Case \$32.50
	1965-66 Woodgrain \$39.50
	1967 Black Camera Case \$63.00
	License Plate Frames 1965-73 \$6.00 pr
	Interior Laquer Paint \$6.95
	Interior Vinyl Die \$6.95
	Pony Kick Panel Chrome \$21.00 pr
	Radio Bezels 1967-68 \$37.20
	1969-70 Black \$27.00
	1969-70 Woodgrain \$33.00
	Lower A-Arm w/Ball Joint 1965-66 \$49.50 ea.
	1967 \$61.20 ea.
	1968-70 \$35.95 ea.
	Coil Spring 1965-68 \$58.80
	1967-68 \$55.05 ea.
	Vinyl Top Chrome 1965-66 \$90.00 pr.
	Vinyl Top Chrome 1967-68 \$60.00 pr.
	Spring Saddles 1965-73 \$39.15 ea
	Taillight Bezel 1965-66 \$14.25 ea.
	Taillight Lens 1965-66 \$4.50 ea.
	Taillight Body 1965-66 \$16.00 ea.
	Vinyl Tops 1965-68 \$47.00
	Watershields 1965-73 Coupe/Conv \$10.95
	1965-73 Fastback \$9.95
	Drip Rail Mouldings 1965-68 Coupe \$69.00 pr.
	Dash Pads 1965 \$159.00
	1966 \$169.00
	1967-68 \$189.00
	1969-70 \$310.00
	1971-73 \$174.00
	Windshield Weatherstrip 1965-68 \$22.95
	Rear Glass Weatherstrip 1965-68 Coupe \$22.95
	1965-70 Fastback \$29.00

Prices subject to change w/o notice
Add 10% for Shipping & Handling
(Minimum \$2.00)

FREE CATALOG

**MUSTANG
PARTS
CORRAL
of TEXAS**



P.O. Box 210524, Dallas, TX 75211
2100 E. Main St. #4A, Grand Prairie, TX 75050

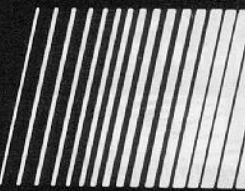

VIRGINIA MUSTANG SUPPLY, INC.

- FAST SERVICE
- HUGE INVENTORY
- GREAT PRICES
- QUALITY PARTS

YOU SHOULD HAVE THIS CATALOG!

If you don't, send \$3.00 for first class mailing (Free with order). 132 pages with over 650 photos. Well organized so you can find what you need for your 64 1/2-73 Mustang.

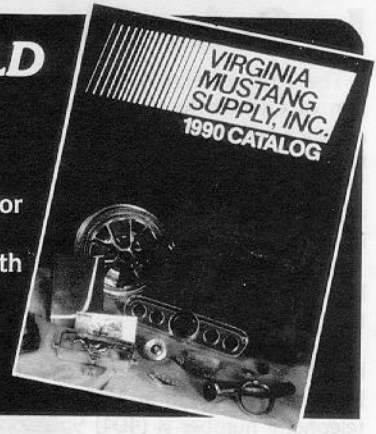

BRAND NEW! 1969 COMPLETE DELUXE DOOR PANELS

High quality plastic backboard won't warp like the original cardboard. Metal reinforcement at top like the original. Includes carpet, just transfer your original trim and cups (or purchase new cups below.) Currently available in black and white. Call for other colors and '70 style panels. These panels are very nice and are priced at only. . . **\$269.95 pair**

NEW! 65-66 FASTBACK DRIP RAIL MOLDING

Finally available **\$59.95 pr.**
65-68 Coupe **\$59.95 pr.**

HIGH QUALITY PLASTIC DOOR PANEL CUPS

69 Long Style (Fit above Panels) **\$29.95 pr.**
70 Short style **\$29.95 pr.**

COMPLETE POWER STEERING HYDRAULIC CONTROL VALVE REPAIR KIT

65-70 Includes ball stud, socket, gaskets and seals. Super value. New—Not Listed in Current Catalog. **only \$59.95 Kit**

MORE DOOR PANELS All Super Quality Panels

65-66 Pony **\$115.00 pr.**
65-68 Std. **\$54.95 pr.**
67 Deluxe **\$149.95 pr.**
68 Deluxe **\$119.95 pr.**
69-70 Std. **Call**

SEAT UPHOLSTERY

Thousands of sets sold. Over 500 sets in stock. Super quality—super prices. Most all original colors available. 67-68 Comfort Weave, 69-73 Std. and others are available that are not listed here.



65-68 Standard
2 Buckets **only \$99.95**
Complete Set **only \$149.95**
65-66 Pony (Pictured)
2 Buckets **\$129.95**
Complete Set **\$199.95**
69-70 Mach 1 & Shelby. Most all Colors!
2 Buckets **\$159.95**
Complete Set **\$239.95**

ORDERING INFORMATION

- Please indicate year, body style, and color of item (if applicable).
- VISA, Master Card, or COD orders accepted.
- \$20.00 minimum order.
- On prepaid mail orders, send cashier's check or money order (personal checks held 21 days for clearance).
- VA residents add 4 1/2% sales tax.
- Add 5% (\$2.50 minimum) for shipping and insurance. (Overpayment will be credited toward next purchase.)
- Fast UPS shipments.
- Prices subject to change without notice.

PHONE (703) 896-2695

HOURS: MONDAY—FRIDAY 9 A.M.—6 P.M.
SATURDAY 9 A.M.—1 P.M.



VIRGINIA MUSTANG SUPPLY, INC.

RT. 259 W., P.O. BOX 487
BROADWAY, VIRGINIA 22815

FLORIDA REGIONAL
MUSTANG CLUB OF AMERICA

PRESENTS THE

FIRST MCA NATIONAL EVENT OF 1991

MARCH 2nd & 3rd

AT WALT DISNEY VILLAGE, 15 MINUTES SOUTH OF
ORLANDO

**SUPER
FORD**
Magazine
OFFICIAL MAGAZINE

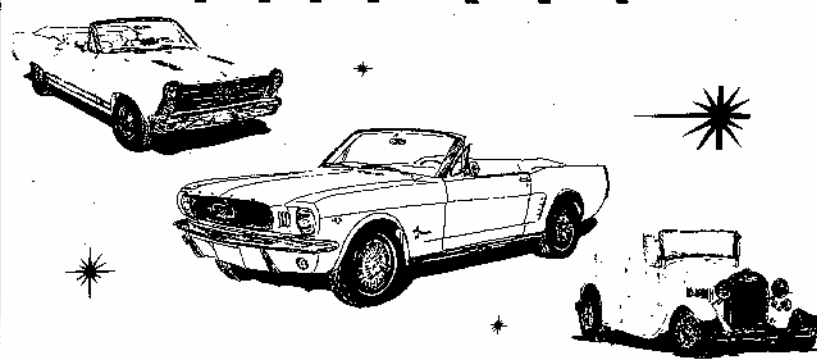
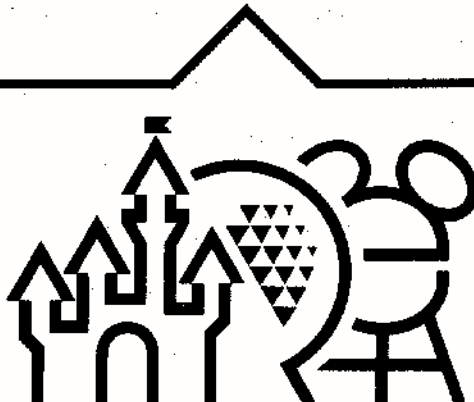

S E C O N D A N N U A L
F L O R I D A R E G I O N A L
M C A S H O W

Walt Disney World®
MARCH 2nd & 3rd 1991

Mustang
Monthly
OFFICIAL MAGAZINE

ROSE
AUTO STORES

Motorcraft 
QUALITY PARTS FOR QUALITY CARS

CORPORATE SPONSOR

- Theme Parks
- Shopping
- Refreshments
- Food

- MULTIPLE SPECIAL INTEREST FORD CLASSES
- ON SITE HOTEL
- ALL PROCEEDS DONATED TO "MAKE A WISH FOUNDATION."

FOR REGISTRATION AND INFORMATION CALL:

STEVE AMES: 813-962-2936 NIGHTS or BRUCE WEISS: 407-259-9089 DAYS, 407-724-0875 NIGHTS

DALLAS

MUSTANG

PARTS

THEY ALL PROMISE THE LOWEST PRICES WHEN YOU WANT MORE — WE DELIVER

WEATHERSTRIPPING

Convertible Body Pillar Weatherstrip

65/68, RH & LH	C5ZZ-7602626-RL	\$ 41.95
69/70, RH	C9ZZ-7602626-A	59.80
69/70, LH	C9ZZ-7602626-A	59.80

Convertible Top Weatherstrips

Made out of long-lasting compression molded E.P.D.M. rubber. Corner sections are bonded, not glued. Highly detailed cross-sections and compound curves. Steel inserts are molded inside rubber. Correct Stud sizes for easy mounting. Complete with installation instructions.

65/68, 5 pcs.	C5ZZ-7651563-R	\$119.95
65/68, Header w/s	C5ZZ-7653986-R	44.95

Roof Side Rail Weatherstrip

65/66, Cpe., repro, excellent	pr. \$ 34.95
65/66, FB, repro, excellent	pr. 64.95

Front Door Weatherstrip

65/66, repro, excellent	pr. \$ 29.95
-------------------------	--------------

Windshield Weatherstrip

65/68	C5ZZ-6503110-A	\$ 39.95
-------	----------------	----------

Rear Window Weatherstrip

65/66 FB	C5ZZ-6342084-A	\$ 39.95
65/68 Coupe	C5ZZ-6342084-A	39.95

Trunk Lid Weatherstrip

65/68, FB	C5ZZ-6343720-BR	\$ 19.95
65/68, Cpe, Cvt.	COMB-6443720-CR	19.95



Door/Quarter Window Weatherstrip Kits

Excellent reproduction as good or better than the original for about half the price. Kits include all pieces for doors and quarter windows, where applicable.

65/66	Eight piece kit	\$ 39.95
67/68	Eight piece kit	39.95
69/70	Eight piece kit	39.95
65/66	4 piece kit for FB	34.95
67/68	4 piece kit for FB	34.95
69/70	4 piece kit for FB	34.95

At DALLAS MUSTANG PARTS we go out of our way to help solve your Mustang parts and restoration problems. We have over a quarter-century of experience in Mustang knowledge that you can count on. Every item you see here—and in our catalog—is in stock and ready for sale and same-day shipping! **SATISFACTION GUARANTEED 100%**



DMP Izod™ Mustang Shirt—The best blend of 60% cotton, 40% polyester golf style shirt with embroidered (not silk-screened) Mustang car on front. Small, medium, large and extra-large. Light blue, dark blue, red or white. **\$19.95**

Call for our new 88 page catalog!



Store location:
9515 Skillman, Dallas, Texas
Monday-Friday 8 AM – 5 PM

VISA-MASTERCARD WELCOME
FREE SHIPPING ON ORDERS \$150.00 OR MORE!

SHEET METAL

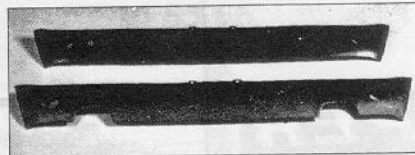

Rear Valance

65/66, w/backup lite hole	C5ZZ-6540544-AR	\$ 49.95
65/66, w/o backup lite hole	C5ZZ-6540544-BR	49.95
67/68, w/o exhaust opening	C7ZZ-6540544-C	49.95
67/68, with exhaust open for GT (see photo)	C7ZZ-6540544-D	49.95

Rear Valance Installation Kit

65/68	PS146, PS113, PS901	\$ 6.65
-------	---------------------	---------

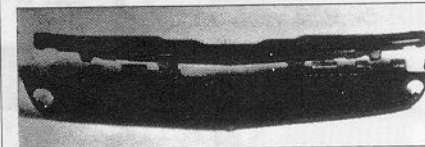

Front Bumper Deflector

65/66	C5ZZ-17779-A	\$ 43.65
67/68	C7ZZ-17779-A	30.80

Front Valance

65/66, with park lite holes	C5ZZ-17A939-AR	\$ 59.95
67/68, with park lite holes	C7ZZ-17A939-AR	59.95

HEADLINER

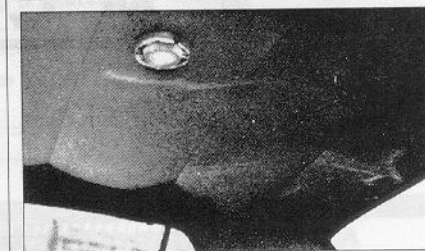

Made of the original moonskin grain vinyl cut to factory patterns. Pre sewn & ready to install. Specify color. For 65/70 Cpe. & FB **\$ 27.85**

ORDER TOLL-FREE
1-800-527-1223

IN TEXAS, CALL
1-800-442-1047

FOR INFORMATION
1-214-349-0991

P. O. BOX 742916
DALLAS, TX 75374

Hot Stuff!



Pantera-Powered Pony Has Proud Past...

MUSTANG

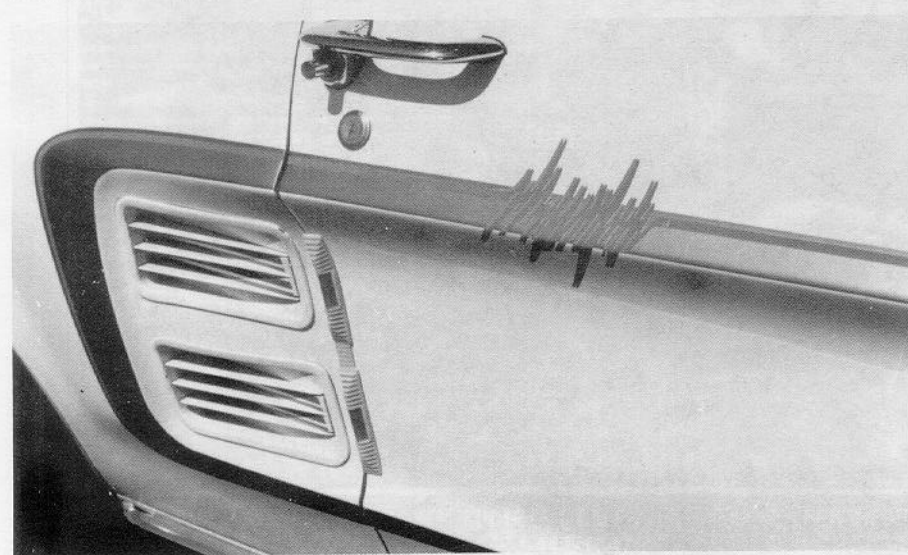
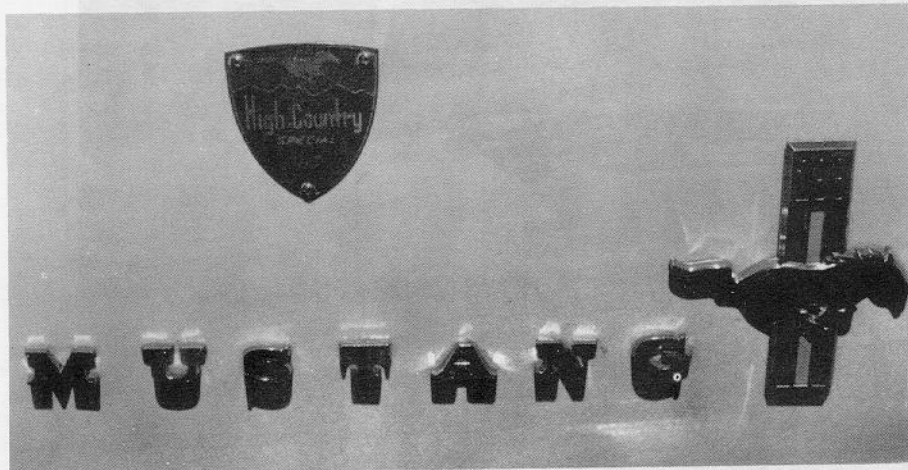

**The Rocky Mountain News
Wednesday, July 12, 1967**

"The largest single shipment of automobiles ever hauled by the Rio Grande Railroad — 400 High Country Special Mustangs — arrived in Denver Tuesday night less than 48 hours after they had left the Ford Motor Company's San Jose assembly plant.

"Thurlo Newell, Ford Division Denver district sales manager, said the cars have been ordered by the district's 100 Ford dealers, with more than half going to the 11 dealers in Denver, Aurora, Golden, Lakewood, Littleton and Wheat Ridge.

"Denver reporters met the 27-car train at Fraser and returned to Denver aboard a luxury lounge car the Rio Grande hooked to the rear of the Mustang Special.

"The High Country Mustangs are painted three Colorado colors — Aspen Golden, Columbine Blue and Timberline Green.

"They are available in all three Mustang body styles — hardtops, convertibles and fastbacks. Each will be identified by the new colors and by a High Country emblem on each front fender.

"Hardtop and convertible models have the 'sprint package,' which includes white sidewall tires, full wheel covers, lowered hood with turn signals, vinyl covered shift lever, bright metal rocker panels and chrome air cleaner.

"Newell said the special Mustangs were ored to keep pace with the demand in the Rocky Mountain area.

"Since the introduction of the Mustang in April 1964, a total of 20,444 Mustangs have been sold in the Denver district.

"Last year Mustangs accounted for 9.5 percent of all new car sales in the Denver Metropolitan Area and, Newell said, its sales are continuing to grow.

"The first month after introduction, 221 Mustangs were sold in the Denver district; in calendar 1964, the total was 3341; in 1965 the number doubled to more than 6500; in 1966 sales rose to 7373 and through the first half of 1967, Mustangs sales were about 3000."

In January of 1990, John Adams of Littleton, CO stopped by Ken's Quality Cars in Denver to do some browsing. He was delighted to find a 1967 Mustang fastback on the showroom floor on consignment.

"I took a close look at the car and decided to buy it because it was modified to my liking," John recalls.

Nine years earlier, the Mustang was sitting in the backyard of a house in the northern part of Colorado, where its new owner decided to begin a few modifications.

The 289 two-barrel was exchanged for a 351C Pantera engine out of a '70 Pantera. The engine was modified, the existing four-speed was replac-

The Mustang Times/January, 1991

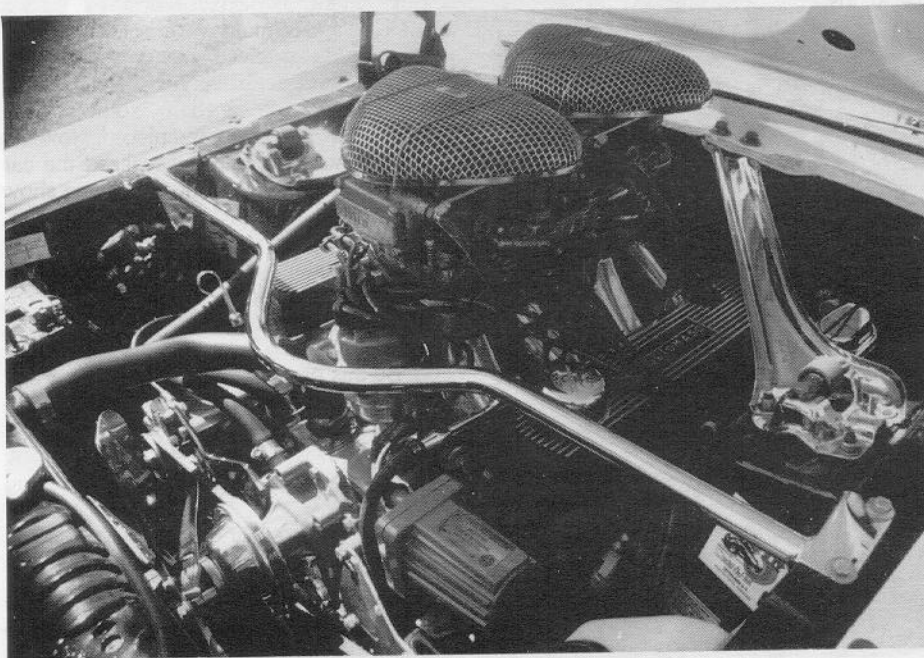
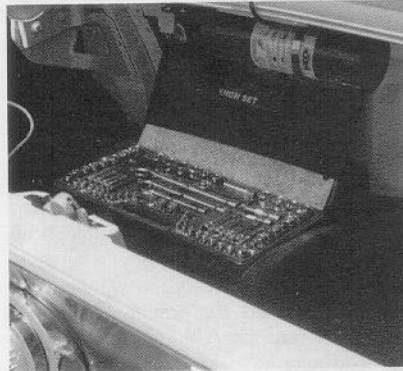

ed with a four-speed close ratio transmission from a Boss 429. The rear end was swapped for a 9" Detroit Locker.

When the work was complete, the engine had a 285-degree cam, 12-to-1 compression pistons, quenched heads, a Weland tunnel port intake, and two 650 CFM dual pumper Holley carbs.

The interior sported bucket seats from a 1969 Mach I and an original roll bar from a 1967 Shelby. The deluxe interior is light and dark blue.

It was eight years later that this modified '67 fastback was sold to a high school student in Evergreen, CO.

Less than a year after that, it ended up at Ken's Quality Cars on consignment.

Impressed by the modifications, John decided to take it home.

A couple of weeks later, he got a pleasant surprise.

"I looked at the data plate and told a friend about it. He advised me to call Bob Teets, who helped me verify that my modified '67 fastback was a High Country Special."

Adams says he had no idea the '67 he bought off the showroom floor in Denver was a High Country Special.

"When I bought it, the car had been used as a daily driver. I had to do body work to the passenger rear quarter and roof. But the body is original, except for the hood scoop and rear spoiler."

Adams also rebuilt the modified Pantera engine. He had the necessary body work done at Highwood Auto Body after which the shop added a coat of Pearl White and Medium Blue Metallic DuPont paint.

John says the '67 Mustang was originally Col-

umbine Blue, one of the three "Colorado colors" used on the '67 High Country Specials.

In the short year he has owned this piece of Mustang history, John — a member of the Front Range Mustang Club and MCA — has used it as a show car, taking second place at the Rocky Mountain Mustang Round-Up in Breckenridge this past summer and third place at the Kansas City MCA National in Overland Park, KS in July.

But he is proudest of his first place trophy won at the MCA Western Grand National in Albuquerque, NM over Labor Day Weekend.

While John is pleased with the modifications to his '67 fastback, now that he has verified that he owns one of those coveted High Country Specials he plans eventually to restore it to original factory specifications.

"I want to put the car back the way it was when it came off the Ford plant floor in California on June 30, 1967," Adams says. "That will include taking the modified parts and changing them over to a regular 1967 fastback."

To date, John says his prized Pony "is the only High Country fastback I have been able to find in existence."

And he still marvels over his luck in landing a bona fide '67 High Country Special that was passing for a "regular '67 fastback" in the dealer's showroom.

But even good fortune has its price.

"Before I bought the car, my wife asked me how I could afford a Mustang if I couldn't afford a hot tub — the one she wanted that I had been putting off buying. Guess what. She won that argument and she got the hot tub a few days later."

Now, John says, they're enjoying both the car and the hot tub!

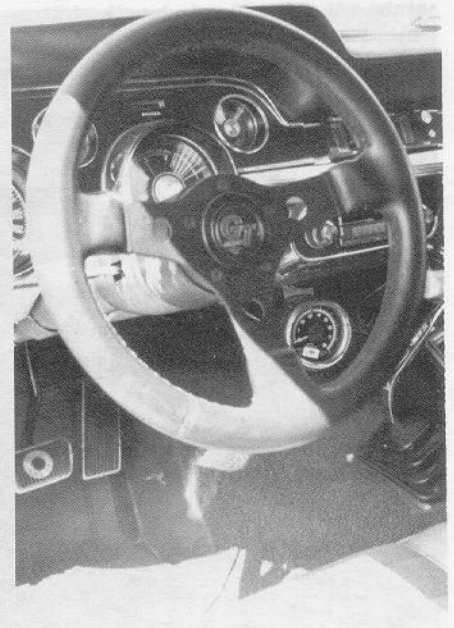

Ray's Mustang: Just What The Doctor Ordered

When Ray Ferrell decided to fix up a Mustang convertible to be used for cruising, he was just following doctor's orders.

The doctor, after all, had told Ray that he needed to relax more — that he should get involved in a hobby.

So what could be more relaxing than tinkering with a classic Mustang and nurturing it back to showroom beauty?

"It sounded relaxing, right?" Ray says.

Ray's wife, Gloria, was thrilled with the idea. The couple, residents of Concord Township, PA, had previously owned a 1971 Mustang convertible.

But when Gloria saw what Ray brought home as his new "hobby horse" she was flabbergasted.

Ray's new hobby came in on a flatbed. The disassembled 1972 Mustang convertible was unrecognizable to all but Ray. And to top it off, it took another trailer to haul home the parts.

"The car had last been driven in 1984 and it was rescued from the salvage yard by a young enthusiast who got discouraged and gladly turned the project over to me," Ray says.

Since his Mustang needed so many parts, Ray decided a parts car would be a good idea.

"But the neighbors kept asking me, 'Which one are you fixing?'"

It took six months, but the car finally began to take shape. All mechanical work was completed and the Pony was ready for the paint and body shop.



"I took the Mustang to my friend Gino Verone of Verone's collision for body work and painting. The car returned so transformed it was unbelievable. Even I couldn't imagine it was the same car!"

Ray then began the process of reassembling his convertible, "a project that took another month of many *relaxing* nights and weekends."

Then, finally, Ray says, "the fun started."

Ray and Gloria took to the road with their "finished product." The '72 convertible, now repainted red with black stripes, was all muscle under the hood where a rebuilt 351 Cleveland provided the power. Other options include ram air, AM/FM radio, power steering, power disc brakes and air. The black interior is deluxe.

Cruising on Saturdays and Sundays, Ray and Gloria received many appreciating glances and thumbs-up signs from passing motorists. Encouraged by others, Ray entered his first show and placed. Now bitten by the show bug, he realized the car needed much more work to become show quality, so he decided to resume "relaxing" nights and weekends.

Belts had to be changed, new hose clamps installed, the trunk and engine compartment had to be detailed and returned to original specifications.

"By this past summer, we were showing the car almost every weekend in Delaware, Pennsylvania or New Jersey," Ray says. "The shows were fun. Besides meeting new friends, the shows were always a learning experience."

In addition to their membership in MCA, Ray and Gloria are also members of The

Ray Ferrell took up Mustanging as a hobby when his doctor ordered him to find a way to "relax" more.



Valley Forge Mustang Club and the First State Mustang Club.

Even though his '72 convertible had won a basketful of trophies during the summer, Ray decided the car would still need a great deal of improvement to be competitive in a national show.

"I had the March 1991 MCA Florida National in mind, so I decided it was time to do some more relaxing. I pulled the motor, started detailing the engine compartment more thoroughly, and tackled the rear end and undercarriage. I'm going to send it back to the paint shop to repair the road nicks encountered from this summer's travel to the car shows. The hockey sticks, along with the plastic chrome on the dash, will be refurbished. I may even add original tires and a new set of Magnum 500s."

So Ray is now spending most of his long winter nights in the garage with his convertible, his new "hobby," which he admits is "just what the doctor ordered."



Ray Ferrell's 1972 Mustang convertible came home on a flatbed — with a trailer full of parts following behind. But after hours of "relaxing" with his Pony in the garage, he finally had the Mustang ready for weekend cruising. Then he made the mistake of entering a car show, and soon found himself back in the garage, working to perfect his convertible. Now he's spending the winter months making even more improvements in hopes of bringing home a trophy from the MCA Florida National early this year.

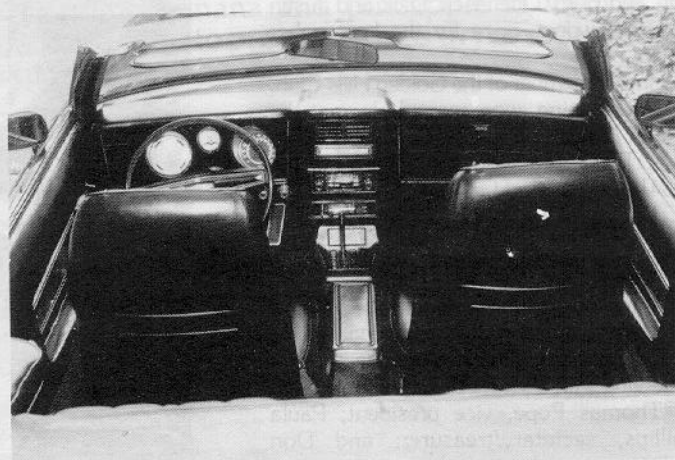
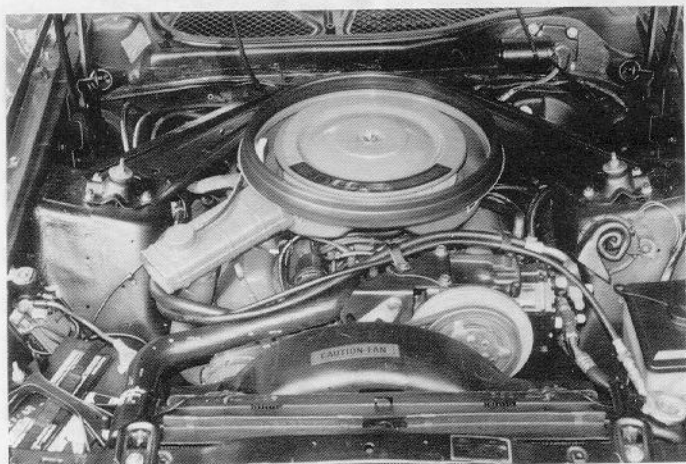

Lynchburg Club Holds 6th Annual Show

The Lynchburg, VA Area Mustang Club held its sixth annual show October 20. This year the club members were singing "Rain, Rain Go Away," for a week before the event, but to no avail.

October 20th was the club's rain date and it dawned clear and cold, but with Mustangers in high spirits.

The home-made chili prepared by the ladies in the Lynchburg club helped warm the day up, but because the group was forced to postpone the show until the rain date, spectator participation suffered somewhat.

Nevertheless, a total of 76 cars showed up for the event.

First, second and third place trophies were offered in 27 different classes. In addition, Best of Show, Best Paint and Hard Luck trophies were awarded.

The hard luck trophy went to a couple from Michigan who showed up on October 13 — the original date. When rain forced the Lynchburg group to postpone the show for a week, the couple decided to stay. In addition to the hard luck trophy, they also won the long distance award.

The club members served complimentary donuts, coffee and hot chocolate for all early morning risers, and despite the chill, the 76 participants and those spectators who braved the elements enjoyed the event.

Golden Hills Mustangers Participate In Road Rally

The Golden Hills Mustang Club held a road rally in late October, attracting 15 cars for the event.

The rally began at 8 a.m. and continued until 1:40. The best time went to Doug and Terri Schultz, who finished the course in 3 hours and 59 minutes.

The award for the slowest time went to Curt and Betty Ocenasek. Dick and Justin Pickering won a prize for the best poker hand.

Another member of the Golden Hills Club, Howard Brining, won second place at the BAMA Mustang Fall Classic held at Fremont Ford. He won the award in the 1964½-66 Restored class.

Tarheel Mustang Club Elects 1991 Officers

Sonny Vick has been elected president of the Tarheel Mustang Club, a regional affiliate of The Mustang Club of America.

Serving with Vick for the coming year will be Thomas Pope, vice president; Paula Phillips, secretary/treasurer; and Don Phillips, national director.



Tennessee Valley Club Hosts Annual Show

The Tennessee Valley Mustang Club held its annual show October 5-7 at Sears in Oak Ridge, TN and attracted more than 60 entries.

All profits from the show were donated to the Amy Gamble Bone Marrow Transplant Fund. Amy is an 18-year-old Oliver Springs, TN girl who is in a life and death struggle with aplastic anemia, a rare, life-threatening disease which affects the blood cells.

The Tennessee Valley Mustang Club, a regional group of MCA, has 60 members in the Knoxville area. The club holds its meetings the fourth Monday of each month.

Mustangers receiving trophies in the club's annual show included:

STREET DRIVEN

1964½-65 Coupe: First Place, T. Bose; Second Place, (tie) J. Reynolds, N. Young, and R. Hamer; Third Place (tie) C. Lemmons and R. Weigel.

1964½-65 Convertible: First Place, M. Millican; Second Place (tie), F. Brown, J. Fellers and D.C. Taylor.

1965-66 Fastback: First Place, J. Kerr; Second Place, S. Lemmons; Third Place (tie), J. Farmer and S. Wiley.

1966 Convertible: First Place, L. York; Second Place, D. Scott; Third Place, R. MaCaulay.

1967-68 Coupe: First Place, J. McMahan; Second Place, V. Smyth.

1967-68 Fastback: First Place, M. Marion.

1967-68 Convertible: First Place, E. Calton.

1971-73 (All): First Place, T. Kincer; Second Place, M. Brown.

1974-89 (All): First Place, B. Murphy; Second Place, S. Webber; Third Place, M. Millican.

Shelbys: First Place, R. Wright.

Modified: First Place, R. Seveasance; Second Place (tie), G. Shields, J. Harrison; Third Place, M. Capers.

Special Interest: First, K. Ledbetter.

TRAILERED

1964½-65 Convertible: First Place, F. Vetterick.

1965-66 Fastback: First Place, F. Gray.

1967-68 Coupe: First Place, Junior & Pat Downer.

1969-70 Fastback: First Place, S. Hightower.

Shelby: First Place, G. Ramsey.

Boss: First Place, J. Burnett.

Long Distance Trophy: Luke and Barbara York of Greensboro, NC.

People's Choice: Jim Reynolds, 1965 Coupe.

Best of Show: Fred Gray, 1966 Fastback.

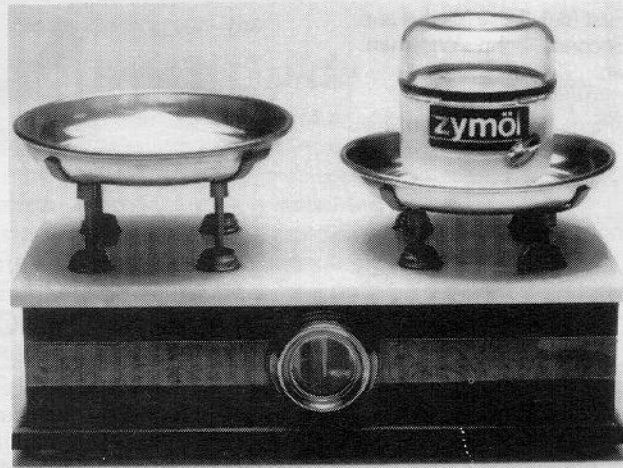

How Does Your Wax Measure Up?

Zymöl is unique in its use of a natural plant oil (Montan) instead of an inexpensive petroleum solvent to make the Carnauba spreadable. It has been engineered to carry pure essence oils of coconut, banana and pineapple to form a moisture barrier on the paint to prevent excess dryness due to sunlight (UV) exposure.

CORCO WEST, INC.

Car Care Division

1-800-533-5743



Mustang Club of Maryland Holds Show

The Mustang Club of Maryland and the Early Ford V8 Club held the annual "Big M Show" in Churchville, MD Sept. 30, attracting 129 Fords from 1930 to 1990.

Proceeds from the event went to benefit the Maryland Special Olympics.

The show was held at the Big M Drive-In, which offers a real 1950's drive-in restaurant and drive-in theater with ample space for more than 130 cars.

The huge field included more than 60 Mustangs. A trophy presentation that afternoon saw 75 car owners win trophies.

Trophy winners included:

1965 Mustang: First (tie), Jesse Mitchel and Tom Droege; Second, John Wiseman; Third, Bill Bogdan.

1966 Mustang: First, Ken Daughton; Second, Bradley Trimble; Third, Andrew Shade.

1967-69 Mustang: First, James Britton.

1970-73 Mustang: First, Nick Budda; Second, Denise Sauerwald; Third, Ray Mebar.

1974-79 Mustang: First, James Hammer.

1980-86 Mustang: First, Rick Merryman; Second, Robert Gobel; Third, Emory Anderson.

1987-90 Mustang: First, Rich Faix; Second, Kirk Momay; Third, Joey Blue.

1969-73 Mach I: First, Chris McAiro; Second, Joe Farace; Third, Jim Lutz.

1969-71 Boss: First, Bob Hare; Second, Keith Nusinov; Third, Harry Kronen.

1965-67 Shelby: First, Charles Beard; Second, Bob Johnson.

1968-70 Shelby: First, Bill Ey; Second, Glen Burnap; Third, Bob Birmingham.

1964-73 L Modified Mustang: First, Butch Hyde; Second, Dennis Daughton; Third, Chip Smith.

1964-73 H Modified Mustang: First, Don Hagermann.

1974-90 L Modified Mustang: First, Doug Denton.

1955-67 T-Bird: First, John Krupinsky; Second, Gene Wallace; Third, Jack Wolfe.

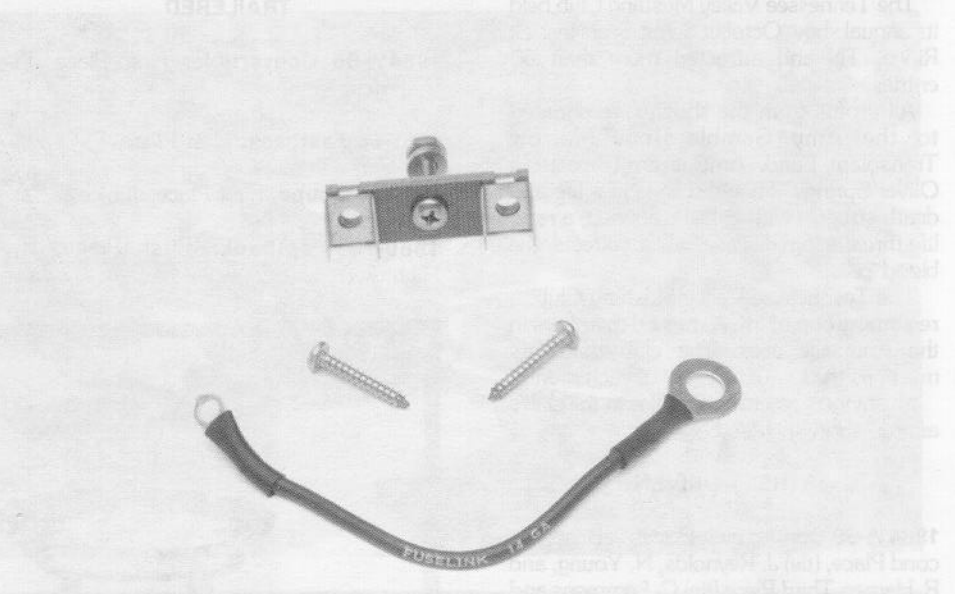

'66 Power Top Circuit Breaker Block Offered

Virginia Mustang Supply Inc. has introduced a 1966 power top circuit breaker block with fuse link. This part needs replacement on virtually all 1966 Mustangs with power tops, according to a spokesman for the company. The kit includes mounting block below starter solenoid, screws and fuse link. "Up until now, this was an impossible part to find," according to Virginia Mustang Supply. The kit retails for \$19.95. Please add \$2.50 UPS charges when ordering. Send money order or cashier's check. COD, cash, Visa and Mastercard orders are also accepted on all purchases totaling \$20 or more. No minimum order if prepaid. Contact Virginia Mustang Supply Inc., P.O. Box 4 87, Broadway, VA 22815 or phone (703) 896-2695.

1958-66 T-Bird: First, Fred Bowles; Second, Don Bubb; Third, John Magnuson.

1930-39 Antique: First, Bruce Hittle; Second, Gary Wilmer; Third, Gus Wurtzer.

1940-49 Antique: First, Richard Lytle; Second, Richard Garrish; Third, Al Quatman.

1950-59 Antique: First, Joe Story; Second, Tom Linch; Third, Scott Myers.

1960-69 Antique: First, Bruce Myers; Second, Steve Boschert; Third, Joe King.

1970-90 Late Model: First, William Dink; Second, Mike Nimmitz.

1903-49 Street Rod: First, William Colosimo; Second, Gary Winas.

1950-63 Custom: First, Charley Lupp; Second, Charles Wall.

1969-90 Street Mac: First, Denny Herr; Second, Pete Henson.

Truck Stock (All): First, Rich Carr; Second, Bill Watkins; Third, Bobbie Carr.

Truck Modified (All): First, Rodger Shakleford; Second, Bryan Lattiar; Third, John McConnell.

Special Interest: First, Mike Altar.

Baton Rouge Results Corrected

The show results from the seventh annual Mustang Round-Up held by the Baton Rouge Mustangers and published in *The Mustang Times* inadvertently omitted two trophy winners.

J.F. Ponder of Mendenhall, MS won first place and John Jackson of Houma, LA won second place in the 1967-70 Shelby class at that show.

The Mustang Times/January, 1991

Valley Forge Group Holds Judging Clinic

The Valley Forge Mustang Club held a Judging Clinic Sunday, Oct. 28, at Sloan Motors in Exton, PA.

Members from the First Pennsylvania Mustang Club, the Lebanon Valley Mustang Club, the North Jersey Mustang Club as well as members of the Valley Forge Club attended.

A free lunch was provided by the club and the members of the various groups enjoyed some social time prior to beginning the clinic.

There was also a discussion among members of the North Jersey Club and the Valley Forge group about making applications for national and grand national MCA shows in 1992.

After some discussions about the do's and don'ts of judging Mustangs and some talk about the judging rules and the recent National Judges' Meeting held in Juneau, WI, members attending the clinic visited Sloan Motor Company's shop where Natalie Gomez's 1964½ and John Schell's 1966 Mustang were used for some "hands on" judging experience.

"The two cars were gone over with a fine tooth comb and we all learned a lot," said Valley Forge Club Vice President Rick Andrews.

"We also talked about how to become certified judges and a packet of information was provided to those who attended.

"I would also like to send out a special thanks to Dave and Brenda Zimmerman from the North Jersey Club for coming down to assist us with the clinic and to Jim Patterson of Sloan Motors for allowing us to use his facility," Andrews said.

Green Country Members Hold Fall Foliage Drive

Eight Mustangs from the Green Country Classic Mustangs of Tulsa, OK were joined by one Thunderbird for a Fall Foliage Drive which included lunch and wine tasting at the Wiederkehr Winery at Altus, AR Nov. 27.

Following the visit to the winery, club members drove to the top of Mt. Nebo and toured Russellville and Dardanelle.

The fall outing continued Sunday as the group caravanned to Petit Jean State Park and the Antique Car Museum. Following a stop for dinner on the return trip, the group arrived back in Tulsa about nine Sunday evening.

Those participating in the trip were Jerry and Stella Bush, Gary and Nancy Girdner with Johnny Girdner and Dan Glass, Curtis and Sue Jones, James and Roxanna

Khoury, Sharon Kruckenberg, Bill Parker, Jack and Jean Penn, Jim and Sharon Slack, Dick and Karen Talley and Willie and Martha Usry.

On Nov. 10, the Green Country Classic Mustangers had 15 Ponies in a display at the Second Annual Salvation Army Classic Those participating included Don Bell, Bob

Black, Jerry and Stella Bush with Michael and Shayna, the Cooks, Harold Crowder, Lucille Duncan, Chuck Harrington with Amy, Alex and Jill, Jim Khoury, Jack and Jean Penn, Craig Rutter with Christopher, Jim and Sharon Slack with Christina, Betty Smith, Dick and Karen Talley, Willie Usry with Allen Usry and Yayoi and Stephanie.

FREE SAMPLE ISSUE

Here is the automotive source you've been looking for—the

Ford Buyer's Guide

with its valuable marketplace for Mustang car and parts. Throughout the pages of the monthly magazine, you'll find useful information on buying, selling, restoring and customizing your Pony; a calendar of events and swapmeets; new products on the market and aftermarket; and a money saving network of mail order new, used and reproduction parts. And, you can sample a current issue FREE.

SEND NO MONEY. Just call our toll-free number and ask for the Ford Buyer's Guide. We'll send your free issue; **NO COST, NO OBLIGATION.** If for any reason, you don't like the issue, just return your invoice for the next 11 issues (a full year subscription) marked "cancel." You'll be under no further obligation and the complimentary issue is yours to keep.

All of this yours for the low subscription rate of \$16.95 for 12 action-packed issues, less than \$1.42 per issue. A savings of over 43% off the newsstand price.

For Faster, More Convenient Delivery

CALL NOW!

FORD BUYER'S GUIDE

"For the serious performance and restoration enthusiast."

Subscribe Toll-Free
1-800-435-0715
 Weekdays or evenings
 7:30am-10:30pm CST

SUBSCRIPTION DEPARTMENT: P.O. BOX 1964, MT. MORRIS, IL 61054-8092

Skip Mason of Peachtree City, GA owns this Meadowlark Yellow/black-topped '68 convertible. The Mustang is powered by a 289 two-barrel and has automatic transmission and power steering. Skip and a friend completed a ground-up restoration on the convertible last year, taking the Pony back to factory-original with the exception of the addition of front and rear stabilizer bars. Skip says he uses the car "whenever the weather is nice." His MCA membership number is 16,272.

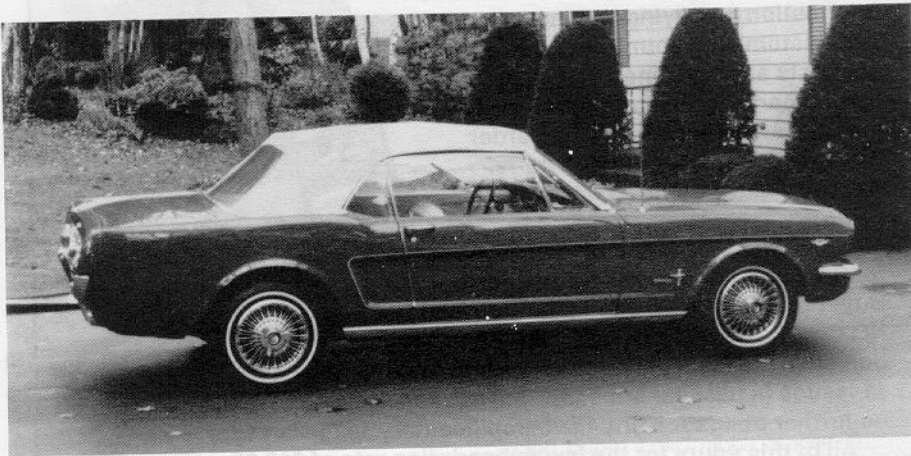

Larry and Carol Richardson of Vernon, VT use their 1964 1/2 Mustang convertible as a driver and show car. Members of the Mustang Club of New England, the Richardsons have completed a full restoration on this Pony. The '64 1/2 is Rangoon Red and includes rally pac, trunk release, wood steering wheel, wire hub caps, console, rocker panel molding, power steering, power brakes and parchment/red interior. The car is powered by a 289-4V. The Richardsons MCA membership number is 23,365.

New MCA members John and Jacky Willoughby of Hockley, Essex, England, are the proud owners of this 1975 Mustang II. The car is powered by a 302 V8. If any MCA members can help John with new running horse decals, he asks that you contact him at 142 Plumberow Avenue, Hockley, Essex 555 5AT, England.



Mustang Times Owner Information Sheet

Your Name _____

Address _____

City _____ State _____ Zip Code _____

Phone _____

How is this car used? _____

What clubs are you affiliated with? _____

When did you buy/inherit this car? _____

Year of car _____

Model _____ Body Style _____

How many miles? _____

Level of restoration/modification _____

Who did body work? _____

What paint was used? _____

Who painted car? _____

What color is car? _____

Give data plate information _____

Type of wheels _____ Tires _____

Options on car _____

Interior color _____ Standard or Deluxe? _____

Engine _____

Who did engine work? _____

Was engine modified? _____ If so, how? _____

Feel free to include a separate sheet with information pertaining to the restoration of your car. Include any stories about locating the car, finding certain parts, or anything else that might make your Mustang unique.

PHOTOGRAPHY CHECKLIST:

Minimum of one roll of 35mm black and white film _____

When shooting the film, did you remember to take front shots _____

rear shots _____ engine shots _____ interior shots _____

special decal shots _____ pictures of any special equipment unique to your particular model _____

When you have assembled your photographs and information, please mail to Steve McMullan, P.O. Box 447, Lithonia, GA. 30058-0447. All Mustang Times Owner Information Sheets received after Jan. 1, 1989 will be acknowledged by return mail within 14 days. Your membership number must accompany your submission. If you desire to have your photographs returned, please include a large, self-addressed envelope. We regret that only a small percentage of the feature articles received can be used as Cover Stories. However, many cars can be featured during the course of the year on the inside pages of the magazine. We encourage you to submit your photographs and information regarding your Mustang. Three to five of the most interesting and unusual will be selected each month for inclusion in the Mustang Times. Mail your owner information sheet today!

MCA Membership No. _____

Still Searching, 50,000 Mustangs Later!

By JIM SMART
With JIM HASKELL

For The Mustang Times

When I sat down to a dusty typewriter in a southwest Oklahoma kitchen during the late summer of 1979 and wrote the first "In Search of Mustangs" column, I was curious — curious about Mustang production and where my own two Mustangs fit in to the big picture.

I had a lot of the same questions many of you have asked Jim Haskell and me over the past several years.

"How many others out there are just like mine? Where are the Mustangs ahead and behind mine on the assembly line? What does 'DSO' mean?" And there were dozens of other questions to be answered.

I wrote a simple letter to then-MCA President Jim Osborn, which was printed in *The Mustang Times*. I asked fellow Mustangers to write with the data from their warranty/serial plates and certification stickers. At that time, I never dreamed where it would lead in terms of numbers of entries — more than 50,000 today — with new input hitting the mailboxes every day. What's more impressive is seeing the serial numbers and data listed on a page — then it all begins to make sense.

The real wiz kid behind "In Search of Mustangs" today is Jim Haskell, owner of a 1964½ Mustang Pace Car coupe and a major portion of the thrust behind the growth of this project since 1987.

Jim stepped in, gathered data in raw form from the files of "In Search of Mustangs," developed a computer program and began inputting the data. The results have been incredible. And Jim's undying enthusiasm has been an immeasurable asset. I couldn't have done it without his expertise and genuine brand of Nebraska-born drive and determination.

Throughout the life of "In Search of Mustangs" we have been receiving your cards, letters and phone calls. Some of you have responded with interesting — often one of a kind — Mustangs with special histories, like Ed White of Macon, GA.

Ed set the mailbox on fire with 5F08F100006, with a date code of "05C" and a DSO code of 840027. Ed's first-day-of-production Mustang (actually built March 9, 1964 though the date code indicates March 5) is a Wimbledon White with red interior convertible found in a salvage yard in South Georgia. There wasn't much left of it when he found it in 1981. At the time, Ed didn't know what he had other, than a low serial number, first-day-of-production car.

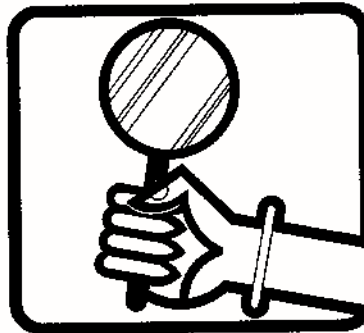

In Search Of Mustangs

By JIM SMART & JIM HASKELL

Paperwork discovered by Donald Farr, then editor of *Mustang Monthly*, indicated that Ed's convertible was one of 12 used at Ford's Magic Skyway exhibit at the 1964 New York World's Fair. Twelve identical 260 two-barrel V-8 drop tops were assembled and delivered to Carron and Company, a Ford contractor given the task of removing powertrains and fuel tanks for weight savings, then outfitting these convertibles for the exhibit. Once outfitted with the necessary brackets underneath to enable these cars to be pulled through the exhibit — plus additional interior lighting — the 12 Mustangs were shipped from Dearborn to New York City in enclosed trucks.

The Mustang convertibles, along with 1964 Ford and Mercury convertibles, were placed on the Magic Skyway where they did their duties hauling spectators, including such notables as entertainer Buddy Hackett, then-Ford Division General Manager Lee Iacocca, Product Planner Don Frey and, yes, Ford Chairman Henry Ford II. These individuals were identified in a photo, one of few witnessed from the exhibit, where the four were seated together in one of the 12 Mustang convertibles.

In the fall of 1964, each of the convertibles was shipped back to Carron and Company where powertrains and fuel tanks were reinstalled, interiors replaced due to wear and tear, then sold off the Ford employee resale lot in Dearborn.

To date, White's 100006 convertible is the only one to have surfaced from the first 12. We say the first 12 because 12 more 1965 Mustang convertibles — identical in appearance — were outfitted by Carron and Company during the winter of 1964-65, then shipped to New York via enclosed trucks. The second 12 units were six cylinder convertibles (no doubt due to a

shortage of 289 V-8s) where powertrains and fuel tanks were removed.

Only one of the second 12 has surfaced and, in fact, was the first World's Fair car to surface in 1978. This one belongs to Al and Gary Schweitzer of Detroit, MI and has been in storage since they bought it. Serial numbered 5F08T383386 with a DSO of 842011 and a date code of "15B" (15 February 1965), the Schweitzer's unusual Mustang convertible was stripped down for a restoration in 1978 and hasn't seen action since.

During a recent conversation with Al, we found they still intend to restore their convertible. However, Gary's career pursuits and other priorities have left the 35,000 original mile Mustang untouched for quite some time. We hope to see this gleaming example of Ford history surface one day at a Mustang Club of America Grand National Show, perhaps for the Mustang's 30th Anniversary in 1994. What about it, guys?

Ed White and 100006 disappeared quite some time ago — their whereabouts unknown today. At last contact in 1985, Ed was still in Macon, GA and 100006 was stored in a barn and up for sale. There's been no contact with White since. Any feedback from our readers is sincerely appreciated.

What's surprising is that of 24 total World's Fair convertibles, only two have surfaced, ironically, one from each grouping. All were sold off the Ford employee resale lot in Dearborn after their brief stints in New York. The best we can theorize is that most of them remained in the Detroit area and were ultimately destroyed by salt spray (rust) or accidents. Odds are very good that some survive with owners who don't understand their histories and who have never taken the time to examine the data plate.

Thousands of Mustangs remain in the hands of non-Mustang oriented people who

The Mustang Times/January, 1991

simply enjoy the cars for what they are. Often the cars lose their special identities through repaints, door replacements, modifications, you name it. At the shows, it always pays to examine Mustangs fitting these descriptions.

This month we have touched upon two of the more notable examples from the files of "In Search of Mustangs." In the months to come, we're going to look back at 12 years with "In Search of Mustangs," get caught up to date, then look to the future.

After years of focusing our efforts on 1965-73 Mustangs, "In Search of Mustangs" will be branching out to include all Mustangs assembled after 1973. This means your 1975 Mustang II Ghia, 1979 Cobra, and 1987 Mustang LX will be of interest to us in our efforts to continue counting America's Original Favorite Fun Car.

Getting **The Mustang Production Guide** to press hasn't been an easy task. Jim Haskell and I are still working out the bugs, though Volume 1 (1965-66) was promised before the end of 1990. As we grove into 1991, the first volume is taking shape and Haskell is busily adding to the 50,000. As we get closer to a publication date, we'll keep all of you posted.

The Mustang Production Guide will be a softbound book of about 300 pages (Volume 1) and will be sized to fit in your glove compartment. Price per copy for Volume 1 is expected to be \$18.95 each pre-publication and \$22.95 each after publication. Club and dealer inquiries are also welcome.

If you would like to be placed on our mailing list, or you have a Mustang you would like to submit to this ongoing census, please write to: Jim Smart, P.O. Box 727, Paris, TN 38242 or Jim Haskell, P.O. Box 883, Annandale, VA 22003.

Regional Groups Urged To Send Election Results

All MCA regional groups are urged to send information on the election of new 1991 officers to **The Mustang Times** as soon as possible after selections are made for the coming year.

Results of these elections will be printed in your club magazine.

Election results are also important to updating our quarterly listing of Regional Groups which appears in **The Mustang Times**.

Please forward information on your new officers as soon as possible after your annual elections.

Suncoast Mustang Club Members Take Trophies At Cypress Gardens

Several members of the Suncoast Mustang Club of Clearwater, FL participated in the ninth annual Cypress Gardens Mustang Show in late October.

Dick and Joan Slacter of the Suncoast Club won best of show with their 1966 Mustang convertible for the second consecutive year.

Other Suncoast club members winning trophies at the Cypress Gardens event included:

John and Helen Watjen, 1966 convertible, best interior;

Bruce and Karen Weiss, 1969 convertible, Best Mustang and Best Shelby with their

1966 GT350;

Juan and Vicki Mursuli, second place, 1965 coupe;

John and Helen Watjen, second place, 1966 convertible;

Ed and Ruby Welcher, third place, 1966 coupe;

Finley and Susan Johnson, second place, 1967 coupe;

Norm and Marilyn Terry, fourth place, 1968 coupe;

Pat and Kathy Reaves, third place, 1973 convertible;

Steve and Debbie Ames, second place, 1973 Shelby.

IN SEARCH OF MUSTANGS

We encourage your participation in "IN SEARCH OF MUSTANGS," an international census of Ford Mustangs and Shelby Mustangs 1964 1/2 through 1973. Data from over 40,000 Mustangs are already included in the census. Make sure yours is in there too!

From this project you'll see monthly updates in the Mustang Times that hopefully will answer your particular concerns or questions on Mustang production facts and other interesting tidbits about our ponies. In addition, a series of full-length Mustang production reference books called the Mustang Production Guide(s), are currently in the writing stage.

All you need to do to participate is fill in the blanks below. The information can be found on a metal plate (1964 1/2-69) or vinyl sticker (1970-73), found on your driver's door near the latch. If there is no plate or sticker, just the serial number is adequate. Total information is very important. Feel free to enclose the history on your Mustang(s).

Name: _____
Address: _____

Mustang # 1. Year _____ Is it a GT, MACH 1, T-5, etc. _____

Warranty/Serial Number _____

Body _____ Color _____ Trim _____ Date _____ DSO _____ Axle _____ Trans _____

Mustang # 2. Year _____ Is it a GT, MACH 1, T-5, etc. _____

Warranty/Serial Number _____

Body _____ Color _____ Trim _____ Date _____ DSO _____ Axle _____ Trans _____

Mustang # 3. Year _____ Is it a GT, MACH 1, T-5, etc. _____

Warranty/Serial Number _____

Body _____ Color _____ Trim _____ Date _____ DSO _____ Axle _____ Trans _____

Thanks for participating in this project. If you desire a reply, please enclose a SASE. Send all information to:

IN SEARCH OF MUSTANGS

Jim Haskell
P.O. Box 883
Annandale, VA 22003

or
Jim Smart
P.O. Box 31425
St. Louis, MO 63131

Engine Idle Adjustment For Thermal Sensing Distributor Vacuum

1967 289 CID Mustangs

The function of the thermal sensing distributor vacuum control valve is to switch the vacuum source for the distributor from the carburetor from the carburetor take-off to the intake manifold when the coolant temperature reaches approximately 230 degrees, which in turn subsequently activates the vacuum mechanism and advances the ignition timing.

An increase in engine idle speed is to be expected by virtue of the additional spark advance and under no circumstances should any attempt be made to reduce the speed by adjustment. When the coolant temperature lowers sufficiently, the idle speed will automatically be reduced.

The thermal sensing distributor vacuum control valve as used on Thermactor air conditioned-equipped vehicles consists of a thermal capsule, similar to the type used in the engine water thermostat, which moves a valve to cover and uncover ports in the valve body thereby switching the vacuum source between the carburetor and the intake manifold depending on the coolant temperature. The vacuum control valve mechanism is an integral part of the heater water takeoff connection and is located on top of the intake manifold at the water outlet fitting. It incorporates three .42" diameter vacuum hose connections which are identified by the letters "C", "D" and "M" denoting connections for the carburetor, distributor and manifold vacuum hoses respectively.

It should be noted that it is mandatory that the distributor vacuum line be disconnected when reading or adjusting the engine initial ignition timing.

The following procedure for adjusting engine idle speed must be followed to avoid erroneous settings on vehicles equipped with the thermal sensing valve.

1. Disconnect the distributor and manifold vacuum hoses at the thermal sensing valve.
2. Plug the manifold vacuum hose.
3. Adjust the engine idle speed in the normal manner.
4. Reconnect the distributor and manifold vacuum hoses to the thermal sensing valve.

(Information for The Troubleshooter is taken from Technical Service Bulletins published by Ford Motor Company for the instruction of their certified dealership mechanics.)

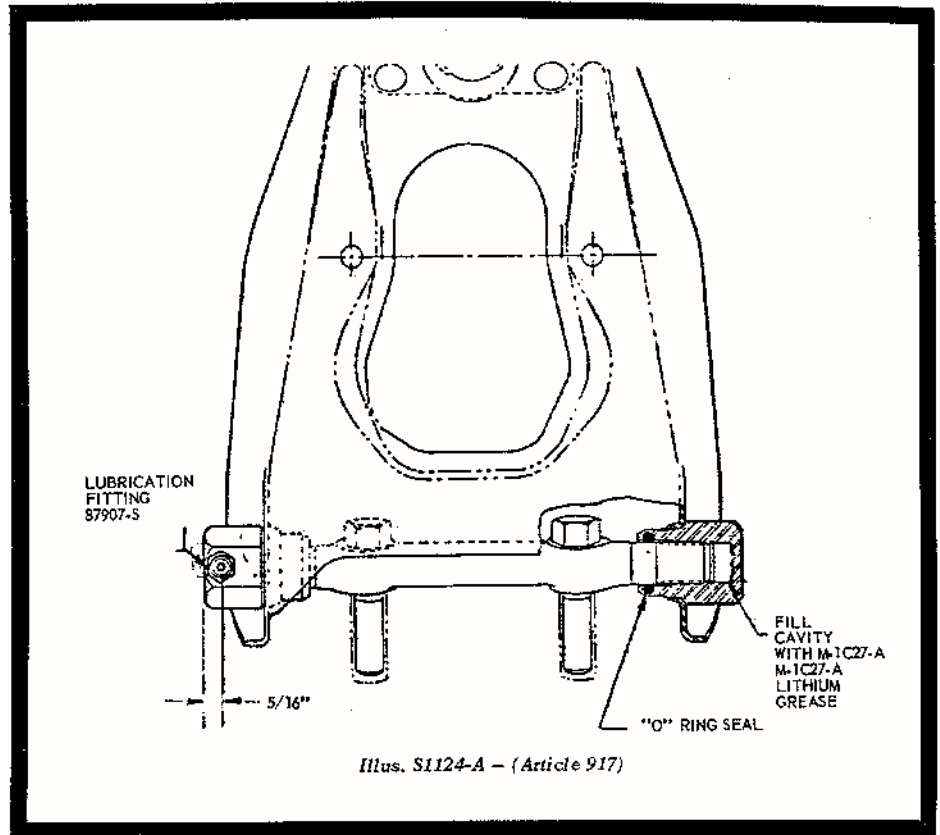

Front Suspension Upper Arm Creak

-1965-66 Mustangs

Field reports indicate that a creaking noise may be experienced at the front suspension upper arm pivots. This condition usually occurs at higher mileages and indicates a need for additional lubricant.

On a customer complaint basis, the upper control arm creak may be corrected by means of the following procedure:

1. Use a hoist or floor jack, placed under the No. 1 crossmember, to raise the front end of the vehicle so that the front wheels can be removed.
2. Place safety stands under the front end, but not under the suspension arms.
3. Remove the front wheels.
4. Through the wheelhouse opening, select the most accessible flat on the hexagonal upper arm pivot bushing. Use a suitable grinding tool to remove an area (5/8" and .020" deep) from the case hardened flat surface of the bushing. (This ground area should be located at the front end of the front bushing and at the rear end of the rear bushing. See Illustration).
5. Center punch a spot 5/16" from the

end of the bushing and on the ground surface of the flat.

6. Use a 3/16 and then a No. 5 drill to make a hole in the bushing (to the center cavity only) at the center punched spot located in Step 5. Be very careful while drilling to keep the drill chips from entering the inside cavity of the bushing. Grease applied on the end of the drill will pick up and remove practically all of the chips.

7. Use a 1/4-28 NF starting tap to thread the No. 5 hole. Use precautions in Step 5 to keep metal chips from entering the bushing cavity.

8. Install an 87907-A (1/4-28) straight lubricator fitting in the tapped hole.

9. Use a hand type grease gun to fill the bushing cavities with long-life lubricant. Apply only enough grease pressure to fill the bushing cavities without causing damage to the bushing "O" ring seal.

Transmission Level Indicator

Effective Nov. 11, 1969, all 1970 transmission oil level indicators will incorporate a new cautionary note "Don't Add If Between Arrows." The fluid level must be checked with fluid at normal operating temperatures.

The Mustang Times/January, 1991

Front Suspension Upper Arm Shaft Bushing Squeaks

—1964½-1969 Mustangs

Lubricate bushings using the upper arm lube kit as outlined below.

1. Raise front end of vehicles keeping the front suspension arms free.

2. Remove the front wheel assemblies to provide accessibility to the upper suspension arm assemblies.

3. Use the 19/64" box wrench to loosen the plug in the end of the noisy upper arm inner shaft bushing (See Fig. 2). Use the circular tool, with hex at center, to finish removing plug.

4. Use the fingers to screw the special lubricating tool into the hole in the end of the bushing — removed plug hole (See Fig. 3). The lubrication fitting on the tool should face outboard when installed. The tool need not be completely tight when in this position.

5. Carefully insert the hypodermic needle between the upper arm inner shaft and the bushing (See Fig. 4). This operation may require some experimentation to find a spot on the periphery of the shaft where adequate clearance between the shaft and bushing is available, due to manufacturing tolerances. The needle will slide in rather easily when the proper spot is found. Do not force the needle. The needle is required to vent the bushing and assure better grease distribution around the threads, and to prevent "O" ring seal "blow out."

NOTE: On some vehicles rust and dirt accumulations will restrict the clearance requiring a smaller diameter needle which can be purchased at a local medical supply.

6. Place hand operated lubricating gun fitting on fitting of the special tool, which was installed in step 4 (See Fig. 4). Apply gun lever pressure. If pressure build-up is felt to be excessive, remove and clean the needle as sometimes semi-dry grease will plug the needle. Re-insert needle and apply lubricant until it comes out the large end of the needle.

7. Remove needle and special tool. Place the plug, which was removed in step 3, in the hex opening of the circular removal and installation tool (See Fig. 5). Use fingers to reinstall plug, remove tool and use wrench to tighten plug to 2-6 lb. ft. (See Fig. 6).

8. Repeat above procedure, if required, on other bushings.

9. Re-install wheel assemblies and lower vehicle.

NOTE: Use upper arm lube kit tool No. T70P-3068-A (included as part of the 1970 essential service tool kit TKIT-1970-A).

The Mustang Times/January, 1991

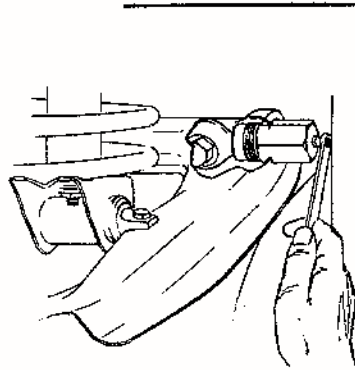

Figure 2 — (Article 1945)

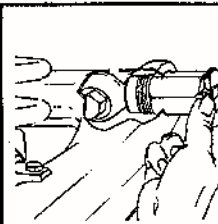

Figure 3 — (Article 1945)

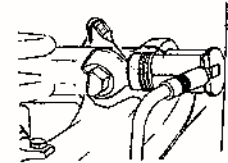

Figure 4 — (Article 1945)

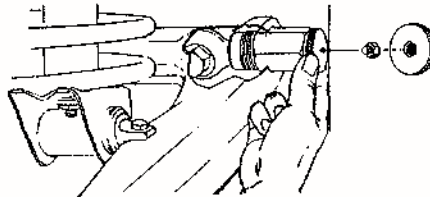

Figure 5 — (Article 1945)

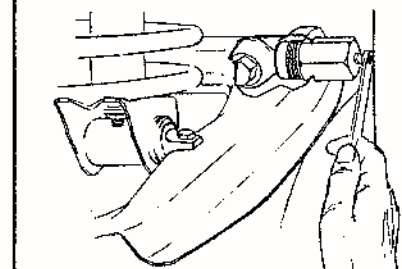

Figure 6 — (Article 1945)

Backup Lamps Remain Illuminated

—1965-66 Mustang

The backup lamp switches on three and four speed transmission units are exposed to road splash and dirt that can cause the switch plunger to corrode and stick in the depressed position. When this condition occurs the backup lamps will remain illuminated until the switch plunger is jarred loose.

On vehicles on which this condition is

reported by owners and on repairs requiring switch replacement, protect the switch plunger from corrosion by following the procedure outlined below:

1. Remove retaining bolt from backup light switch and position switch away from shift housing.

2. Clean corrosion from the plunger shaft and apply a light coat of lubricant.

3. Fabricate a boot from a tailgate limit switch seal C5AZ-14A353-B and install boot to switch plunger (See illustration).

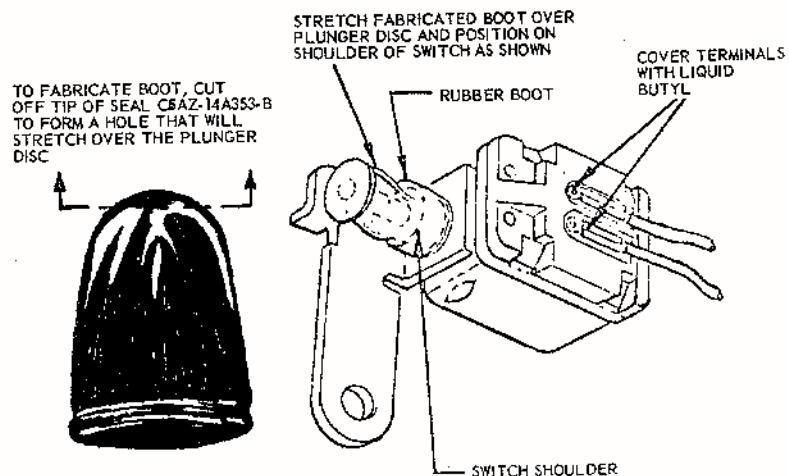

AUTOMOTIVE PURSUITS, INC.

presents

COMPU CLASSICS MUSTANG VOLUME I

The most complete database ever assembled for the 1964½-1968 Mustang is now available on one 5¼-inch floppy! How many hours have you spent looking for a specific piece of data? Put it all at your fingertips with **Compu Classics!**

Two years in the making, we offer over 100 screens of accurate, highly researched, informative data. Color schemes, Engine codes, Option codes, Production quantities, Data Plate Codes, Transmissions, Rear axles, and MUCH, MUCH MORE!!

Whether you own a classic Mustang or are thinking about buying one, our database will prove to be invaluable to your restoration project or potential purchase.

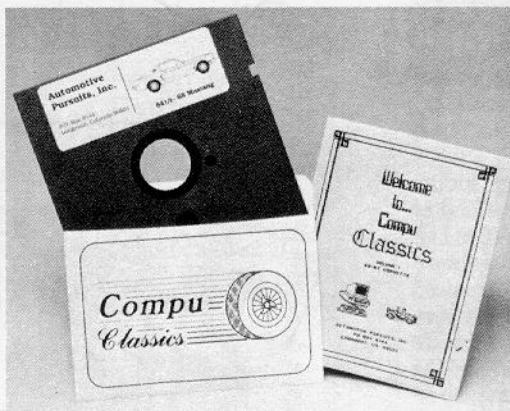

The key to an intelligent investment is ORIGINALITY. **COMPU CLASSICS** provides the raw data you need, while highlighting those items which collectors seek most.

Our program runs on any **IBM PC/XT/AT** or compatible computer. User friendly, menu driven screens are easily reproduced in hardcopy form when you need to take a piece of data with you. Run off a hardcopy of our TUNE-UP section, take it to the garage, and wipe your hands on the printout when you're done! No need to get grease all over that expensive manual.

Order Now!! Call our 24 hour a day hotline...

1-303-678-9164

or send check or money order to:

AUTOMOTIVE PURSUITS, INC. P.O. BOX 8144 LONGMONT, COLORADO 80501

(We Accept VISA and MASTERCARD)

PRICE INCLUDES SHIPPING AND HANDLING. PLEASE INCLUDE HOME ADDRESS IF ORDERING BY MAIL. ALLOW 2-3 WEEKS FOR DELIVERY.

ORDER # FMT001

VOLUME I 1964½ - 1968 MUSTANG..... \$29.95

* Colorado residents add 6% sales tax

TOTAL

Johnni Larsen Denmark
 Paul Deluca Bayonne, NJ
 Richard Silva Mahwah, NJ
 Eric Cronce Elverson, PA
 James Felts Ronda, NC
 John Fox E. Lansing, MI
 Thomas Stortz Janesville, WI
 Jim Dudley Rapid City, SD
 Rich Sagen Rapid City, SD
 Ben Pepper Aurora, CO
 Burton Dezendorf Englewood, CO
 Mark Eckrich Cheney, WA
 John Willoughby England
 Anthony Jeffery Middleboro, MA
 Joe Coleman Jr. Middletown, NY
 Joseph D'Ambrosio Glen Head, NY
 Michael Engler S. Williamsport, PA
 John Driscoll Conshohocken, PA
 Ralph Prichard Fallston, MD
 Fred Prickett Virginia Beach, VA
 Perry Bradshaw Waverly, VA
 Lisa Lau Chapel Hill, NC
 F.R. Corley Irmo, SC
 Andrew Burke Marietta, GA
 Sheri Jaynes Norcross, GA
 Elliott Linhoss Duluth, GA
 The Gadlage Family Lilburn, GA
 J.J. Mascara Peachtree City, GA
 Harvey Lester Pensacola, FL
 John Wayne Taylor Montgomery, AL
 Jamie King Montgomery, AL
 Wayne Barfield Montgomery, AL
 Dennis Charlesworth Montgomery, AL
 Ricky Brooks Montgomery, AL
 Jeffrey Johnson Montgomery, AL
 Dexter White Hixson, TN
 Ralph Stambaugh North Olmsted, OH
 George Houchins Haubstadt, IN
 John Prokop St. Paul, MN
 Robert Kimmel W. St. Paul, MN
 Paul Dudek Minneapolis, MN
 John Bryan Chicago, IL
 Gregg Cly Dallas, TX
 John Cox Burnet, TX
 Jerry Andersen Las Vegas, NV
 Mathew Clopp Santa Clara, CA
 R.C. Snyder Tacoma, WA
 Laurence Larsen London, England
 Bambi Bernstein Lincroft, NJ
 Steve Miller Huntington, NY
 Douglas Rumphorst Huntington, NY
 Barbara Ann Bunda Waldon, NY
 Elizabeth Negus Ames, NY
 Dennis Honeywell Clayton, NY
 A. & B. Anderson Wescosville, PA
 John Poole Chalfont, PA
 David Truax Perkasia, PA
 John Doyle Bensalem, PA
 Steve Moir Sharon Hill, PA
 Keith Larsen Baltimore, MD
 Ron Miller Springfield, VA
 Harry Lunsford Stauton, VA
 Ralph Holland Greensboro, NC

MCA's Newest Member

Francis J. Zurst of Blue Bell, PA is the newest member of The Mustang Club of America, logging in with membership number 23,649. We welcome Francis and the scores of others named here to MCA and look forward to sharing the Mustang hobby with these new members.

B.E. Triplett Jr. Concord, NC
 Robbie Hill Conover, NC
 Carol Sease Pomaria, SC
 Stanley Wrinkle Marietta, GA
 Chris Reid Americus, GA
 Jeff Dworek Pensacola, FL
 Jack Swain Sorrento, FL
 Ron Mazzaro Coconut Creek, FL
 Christian Bodemann Palm City, FL
 Jeffrey Lewis New Tazewell, TN
 Larry Connell Milan, TN
 William Graham Columbia, TN
 Candace Slawson Brandon, MS
 Doug Hambleton Dublin, OH
 Ron Kaeser Cincinnati, OH
 Boss Bertsch Willis, MI
 Buddy Belzer Rapid City, SD
 Paint-N-Place Cassville, MO
 Michael Coutee Chopin, LA
 John Brooks Batesville, AR
 Mark Taylor Huntsville, TX
 Dr. Paul Bunnell Port Lavaca, TX
 Paul Webb Odessa, TX
 Robert Ruiz Glendale, CA
 Dan Delahoyde Corona, CA
 Al Brensnick Santee, CA
 Edi Brunner Blauen, Switzerland
 Joe Jurcik Alberta, Canada
 Bernie Johnson Wallington, NJ
 Paul Matinho Warren, NJ
 Rich Zotta Bloomingdale, NJ
 E. Paul Leedom Wyckoff, NJ
 Howard Bateman Somers Point, NJ

Dr. David Hoffman Bethlehem, PA
 Rick Carosi Folcroft, PA
 Charlie Mowday West Chester, PA
 Francis Zurst Blue Bell, PA
 Robert MacKenzie Frederick, MD
 Steve Morgan Rocky Mount, NC
 Russ Neal Tucker, GA
 David Rankin Miami, FL
 Tim Dexter Dunedin, FL
 Bill Cunningham Memphis, TN
 R. Alan Rail Jackson, TN
 Aric Griffin Jeffersontown, KY
 David Fangman Park Hills, KY
 Charles Copher Elwood, IN
 Steve Kalan Canton, MI
 Dean Wold Green Bay, WI
 Holly Hansen Rapid City, SD
 Phil Merlo St. Louis, MO
 Constance Stern Scottsdale, AZ
 Stephen Lepper Clovis, CA
 Matthew Henkel Erial, NJ
 Jill Shannon Harrisburg, PA
 John Kerchner York, PA
 Frank Healey Carbondale, PA
 Ronald Hudson Newark, DE
 Linda Pototschnik Mount Airy, MD
 Chip & Mary King Fairfax, VA
 Paul Ianuario Sr. Greer, SC
 Edward Welcher Clearwater, FL
 Neil Melander Palm Harbor, FL
 Judy McCarthy Knoxville, TN
 Susanne Dalton Terry, MS
 Dr. Ronnie Harrison Hattiesburg, MS
 Doug Monroe Columbus, OH
 Harold Schichtel Columbia Station, OH
 Don Kyser Columbiana, OH
 Glenn Hamilton Dayton, OH
 Thomas Schatz Richfield, WI
 Dennis Degner Watertown, WI
 Jason Hurd Rockham, SD
 Dean Hartford Rapid City, SD
 Leo Herdina Rapid City, SD
 Michael Kinch Dallas, TX
 Steve Barnes Upland, CA
 Doug Richards Issaquah, WA
 David Carlson Mt. Vernon, WA

MCA Approved

Reproduced 65-68 Anti-Vibration Compressor Braces
 65/66 MCA #90-018 • 67/68 MCA #90-019



TONY & NATALIE RINALDI

P.O. Box 2178, Palos Verdes Peninsula, CA 90274 (213) 377-5889

North Charleston Mustang

1943 Remount Rd. North Charleston, SC 29406

65-68 Door Panels . . . \$59.95	65-68 Ft. Valance . . . \$39.95
65-70 Headliner . . . \$26.95	65-68 Rear Valance . . \$39.95
65-66 Dash Pads . . . \$159.95	65-66 Doors (New) . . \$249.95

Complete inventory of new Ford and Repo parts. We also have over 200 65-73 parts cars disassembled and ready to ship. We pay UPS on all orders over \$250.00 in Continental USA. COD welcomed. Catalog shipped same day, \$3.00.

For Information
Free Catalog
1-800-747-1857

Orders Only
1-800-624-1253

64½ MUSTANG 66 AIR-CONDITIONING

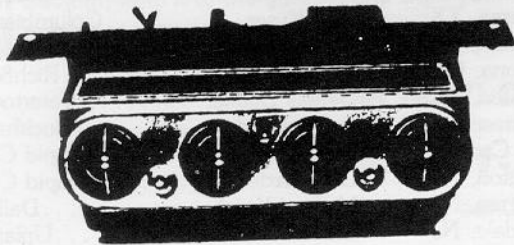

One Part or Complete System
TRY US!

ALL FORD
Under-dash units
and clutches remanufactured!!
Parts available through 1973
Dealer Inquiries Welcome
Call or write for **FREE CATALOG**

CLASSIC AUTO AIR MFG. CO.

Unit MT, 2020 W. Kennedy Blvd.
Tampa, Florida 33606
813-884-3681 • 813-251-2356

Woodhaven, MI

The 10th Annual Ford Indoor Swap Meet, sponsored by the Shelby American Automobile Club — Motor City Region, will be held at Gomo Ford from 9 a.m. to 3 p.m. For additional information call (313) 427-2449.

January 27

February 1

Atlanta, GA
February 1, 1991 is the deadline for the receipt of applications from regional groups interested in hosting the 1992 MCA Grand National. Applications are available by writing MCA, P.O. Box 447, Lithonia, GA 30058. Selection of the site for the 1992 MCA Grand National will be made at the March meeting of the MCA Board of Directors.

February 3

Nashville, TN
The Stones River Region AACA will hold its third annual swap meet and flea market. A \$2 donation will be collected at the door. For information contact Jesse Harvey at (615) 896-3404 nights or (615) 893-1814 days or Butch Roth at (615) 367-0945 nights or (615) 893-8004 days.

February 3

Moorpark, CA
The Mustang Owners Club of California will hold its "All Ford Round-Up," co-sponsored by Vista Ford, at Woodley Park. Pre-registration is required. Registration forms must be postmarked no later than Jan. 26, 1991. No cars will be registered the day of the show. Concours and Peoples' Choice Judging will be offered. Concours participants will be required to judge. Entry fee is \$15 for Concours Cars and \$13 for Peoples' Choice. Cars must be parked between 8-10 a.m. Spectators will be admitted free. For more information call Wayne at (818) 343-2091 or Joe at (805) 529-3245. Make registration checks payable to Mustang Owners Club of California and mail to Joe Ritz, 4360 Autumn Meadow, Moorpark, CA 93021.

February 17

Irwindale, CA
The Pacific Mustang Club will hold its Springtime Car Show in the Park at Irwindale Recreational Dam. Judging will be peoples' choice. There will be games for children, a volleyball tournament, barbecue and picnic. Entry fee is \$13 per car and the park charges a small entry fee. There is no charge for spectators. Rain date is February 24. Cars must be pre-registered by February 10. For additional information contact the Pacific Mustang Club, P.O. Box 33634, Granada Hills, CA 91344.

February 23-24

Monticello, IW
The 22nd Annual Rod and Custom Show will be held at the Youth Center Building. There will be numerous classes for Mustangs. Cash and trophies will be awarded. For additional information contact Ralph or Galen Miller, 853 Southhaven Drive, Monticello, IW 52310 or call (319) 465-5119.

March 1

Atlanta, GA
March 1, 1991 is the deadline for the receipt of applications from regional groups interested in hosting 1992 MCA National shows. Applications are available by writing MCA, P.O. Box 447, Lithonia, GA 30058. Selection of sites for 1992 MCA National shows will be made at the April meeting of the MCA Board of Directors.

March 2-3

Orlando, FL
The Florida Regional Mustang Club will host the first MCA National of 1991 at Walt Disney Village in Orlando, FL. MCA rules will apply. Registration opens at noon March 1 and continues until 11 a.m. March 2. Awards will be presented at a breakfast banquet Sunday, March 3 so they may be displayed with cars on the final day of the

show. All show car entries will receive two free passes to either the Magic Kingdom, Epcot, or MGM Studios, plus two free tickets to Pleasure Island. There is no admission charge for spectators. For information contact Steve Ames at (813) 962-2936 or Bruce Weiss at (407) 259-9089 days or (407) 724-0875 nights.

March 23-24 **Plant City, FL**
A Power Performance Show will be held at the Florida Strawberry Festival Grounds. General admission is \$4. A car and truck parade will be held at 5 p.m. Saturday. Classes for Mustangs will be included. First, second and third place trophies will be awarded Sunday afternoon in each class. Vendor spaces are available. For additional information call (813) 752-0192 or (813) 754-1032 or write Power Performance Show, 3905 N. Wilder Road, Plant City, FL 33565.

March 29-31 **Pensacola, FL**
The Gulf Coast Regional Mustang Club will host an MCA National Show at University Mall in Pensacola. MCA rules will apply. For registration and lodging information write: Gulf Coast Regional Mustang Club, P.O. Box 10126, Pensacola, FL 32524. Also, tickets for a Springtime Yellow 1966 Mustang convertible, to be given away on the final day of the Pensacola show, are available for \$1 each or six for \$5 by writing the same address.

April 17 **Detroit, MI**
The 27th anniversary of the introduction of the Ford Mustang, which was first offered for public sale on April 17, 1964.

April 26-28 **Nashville, TN**
The Music City Mustang Club will host the 1991 MCA Southeastern National Show. Show headquarters will be the Marriott Hotel, 1 Marriott Drive, (615) 889-9300. The hotel is located at I-40 East, exit Briley Parkway North to Elm Hill Pike East. For registration information and details call Frank at (615) 227-5671 or Joe at (615) 790-6792, or Gene at (615) 883-7866 or write Music City Mustang Club, 1028 Dozier Place, Nashville, TN 37216.

April 19-20 **Port Arthur, TX**
The Southeast Texas Mustang Club will host its sixth annual Regional Mustang Show. Show site will be Central Mall in Port Arthur. Host hotel will be the Holiday Inn Park Central. For hotel reservations call (409) 724-5000. A hospitality party with a live band will be held Friday night. An awards banquet will be held Saturday night. Trophies will be awarded in all classes and for participation cars. A student class will also be provided. Students must be between the ages of 16 and 21 and enrolled full time in high school, college or a vocational-technical program. For additional information contact Bob Davenport at (409) 727-1052 or write to Southeast Texas Mustang Club, P.O. Box 8848, Lumberton, TX 77711.

May 4 **Mobile, AL**
The third annual Mobile Bay Mustang Roundup will be held at Bel Air Mall. There will also be special interest classes for Ford-powered vehicles. For information contact the Mobile Bay Mustang Club, P.O. Box 8713, Mobile, AL 36689 or phone (205) 344-2643.

May 11 **Dixon, CA**
The Golden Hills Mustang Club will hold its seventh annual "Biggest Little Car Show" for Ford Mustangs at Ron Du Pratt Ford, 1320 First Street. The show is open to all Mustangs and Shelby models, from daily drivers to trailered show cars. There will be five classes offered, including a "Fun" class. Trophies will be awarded in each class. For entry forms and information call Robert Rand (707) 426-3103 evenings between 7-9 p.m.

May 18 **St. Petersburg, FL**
The Suncoast Mustang Club will hold its fourth annual Mustangs on the Pier Show, featuring 22 judged classes of Mustangs and Shelbys with a special interest Ford class included. Pre-registration is \$12. Show day registration is \$15. All festivities will be held on the pier with general admission free. For information contact John Moody at (813) 786-3048 or Bob Wilhelm at (813) 522-0858 or write Suncoast Mustang Club, P.O. Box 4622, Clearwater, FL 34618.

May 25-26 **Kennewick, WA**
The 11th annual Spring Show & Shine and Fun Run, presented by the Pacific Northwest Mustang Club, will be held at Cavanaugh's, 1101 Columbia Center Blvd. The Fun Run and a Hospitality Party will be held on the 25th and the show will be held on the 26th. Participant voting and people's choice awards will be presented at a banquet following the show. The event is open to all Mustangs, Bosses, Shelbys, Ford-powered cars, non-Fords and vendors. Trailered cars are also welcome. For information contact Harold L. Odahlen at (509) 377-2239 days or (509) 783-6309 evenings.

May 31-June 1 **Springfield, IL**
The Central Illinois Mustangers will host an MCA National Mustang Show. Show headquarters will be Holiday Inn East. MCA rules will apply. For registration and lodging information write: John Murphy, President, Central Illinois Mustangers, P.O. Box 845, Paunee, IL 62558. Additional information on this MCA National will be published in future editions of **The Mustang Times**.

less than 500 available!

GOLD PLATED EMBLEM KEYS

Makes the Perfect Gift!



For all **MUSTANGS** please specify year & check key for single or double cut.

Other Collectible Keys Available

\$12.50 plus \$2.00 postage & handling for each key.
(Ohio residents add 68¢ sales tax.)

Please include phone # with order.

Send check or money order to:

JESSER'S AUTO CLINIC
26 West Street • Akron, Ohio 44303

(216) 376-8181

*Keys are mailed uncut and can be cut at any key shop.
Please allow 1 week for delivery. Keys are mailed first class.*

Member # 23296

CALENDAR OF EVENTS

June 2

Bloomington, IL

The 10th annual Central Illinois Ford Day Show and Swap Meet will be held at Bob Dennison Ford. There will be 32 classes for all Fords. Trophies, dash plaques and door prizes will be awarded. Food and drinks will be available on the grounds. For information contact Central Illinois Mustang Association, C/O Steve Lubbert, RR 3 Box 407A, Bloomington, IL 61704 or call (309) 963-4536.

June 14-15

Lakewood, CO

The third annual Rocky Mountain Mustang Roundup, the largest Mustang show in Colorado, will be held. The event is co-sponsored by six Colorado Mustang clubs. For additional information call Lil at (303) 751-3105, Ron at (719) 475-7369 or Jean at (303) 499-6507. Vendors, entrants and spectators are all welcomed.

June 21-22

Hollywood, CA

The "National Fabulous Hollywood Car Show," hosted by Pacific Mustang Club, will be held. The show will be at the Beverly Garland Hotel. Entry fee is \$25 and all cars must be pre-registered by June 14. Admission to the public is free. There will be a Friday evening cocktail party. Saturday will feature the car show, raffles, a banquet and an awards presentation. For additional information write Pacific Mustang Club, P.O. Box 33634, Granada Hills, CA 91344.

July 12-14

Lithia Springs, GA

The Georgia Regional Mustang Club, in cooperation with John Bleakley Ford, will sponsor the 1991 Atlanta MCA National. The

event will be held at the dealership in Lithia Springs off I-20 west of Atlanta. Additional details on this show will be included in future issues of **The Mustang Times**.

August 16-18

Kingsport, TN

The 1991 MCA Grand National will be held outdoors at the Kingsport Convention Center. For registration and lodging information write: First Tennessee Regional Group, P.O. Box 512, Hillen Valley Road, Kingsport, TN 37663. Additional information on this MCA event will be published in future editions of **The Mustang Times**.

September 8

Long Beach, CA

The Pacific Mustang Club presents its fourth annual Eldorado Picnic and Car Show. Judging will be peoples' choice. Activities will include games for children, a volleyball tournament, door prizes and an awards presentation. Entry for the show is \$14 per car if pre-registered by August 29. The park itself will charge a small entry fee. Rain date is September 15. Spectators attend free. For additional information write Pacific Mustang Club, P.O. Box 33634, Granada Hills, CA 91344.

(The Mustang Times welcomes items for its monthly calendar of events. To have your event included in our calendar, please send full details including date, location, time, and contacts, including telephone numbers with area codes to: Calendar of Events, The Mustang Times, P.O. Box 447, Lithonia, GA 30058. Please submit items at least 60 days prior to the event to insure inclusion on a timely basis.)



ORIGINAL AUTOMOTIVE ILLUSTRATION

One of a kind, hand drawn, true-to-life color illustrations of your prized collector car! Each illustration is a unique creation of incredible detail, drawn directly from your photograph. Each Trainor original comes matted and is available with or without frame and mounting hardware. Black and white pen and ink illustrations are also a specialty. Call us for any type of automotive illustration. Please allow 3 weeks for delivery.

The Perfect Idea for That Once-In-A-Lifetime Gift, Fund Raisers, Club Prizes, Raffles, Etc.

939 Dallas Way • Lawrenceville, GA. 30245 • (404) 963-7840

Cars For Sale

1966 Mustang GT coupe, V8, AT, black with red deluxe interior, console, styled steel wheels, new tires, rebuilt motor and transmission, no rust. Price: \$8,000. Call Owen Tomlinson after 3 p.m. at (804) 239-1594.

1969 Mach I, Acapulco blue, refurbished on a solid metal body, in-dash tach, 4-speed, PB, PS, hood scoop, factory AM-FM, new tires, louvers, spoilers on a beautiful driving and looking detailed auto. Upcoming college tuition forces sale. Price: \$10,000. Call (309) 897-3371.

1966 Mustang convertible, Wimbledon White, white top, red deluxe Pony interior, AT with console, 200 Sprint, wire wheel covers, complete restoration in 1989 of solid Florida car. Will trade for 1969-70 Mach I of close value at \$10,500. Call (717) 424-5762.

1985 SVO Mustang, Oxford White, gray cloth interior, only 57,000 true miles, one of only 1,954 built. Get one while they are still affordable. Price: \$7,495. Call (818) 856-5168.

1973 Mustang convertible, 302, power steering, power brakes, factory original blue metallic paint, original white top, medium blue comfortweave interior. Unrestored MCA show car. Pocono Grand National originality score was 578 points out of 594 possible. One beautiful car. Price: \$11,900. Call (717) 473-8095.

1966 Shelby GT350H, No. 1396 plus famous Hi-Po trailer. Class winner at SAAC-15 in Dearborn in 1990. You have seen it in Mustang Monthly, August 86 and Autoweek. Your chance to own the most famous Hertz. Need money for concours '67 GT350. Price: \$55,000 OBO. Call Bob Stroud at (919) 276-8202.

1966 Mustang GT coupe, Nightmist Blue, A-Code, optional four-speed transmission, new clutch, all original GT. Drive anywhere. VIN 6R07A156902. Call Chuck at (713) 453-6464 or (713) 455-5544.

1966 Mustang 200 Sprint, professionally

restored. Lady's pampered, garaged baby. Candy Apple Red, black interior, AT, wire-styled wheel covers, 95,000 actual miles. Have all receipts. Price: \$7,850 firm. Call Karen Laren at (206) 696-0244 evenings.

1965 Mustang "K" convertible, VIN 5F08-K792638. Rangoon Red/Red Pony interior, four-speed, no drivetrain. Rust and body damage but restorable. Price: \$8,000. Have non-matching Hi-Po engine, toploader, clutch assembly, driveshaft and 9-inch 3.70 rearend for \$2,500. All for \$10,000. Call (314) 921-3673.

1966 Mustang, two-door hardtop, 289-2V, AT. Candy Apple Red with black standard interior. Virginia car in excellent condition. Purchased from original owner. All original except for paint. Price: \$7,195. Call (717) 766-0961 days or (717) 766-1685 evenings.

1966 Mustang convertible, Candy Apple Red, white top, standard black interior, console, 200 cu. in. six, AT (C4), power top, 70,000 miles, fully restored. Garaged with car cover. Choice collectible. Price: \$7,800. Call (609) 654-1968.

1966 Mustang, six cylinder, 3-speed, black with red interior, garaged since 1987 when body work and paint were completed. Price: \$5,500. Call Mike at (215) 353-4847.

1969 Mustang coupe, 302, V8, AT, 72,000 miles. All original, second owner (since 1976).

Garage kept. Metallic green, new paint. Complete maintenance records for past 8 years. Always driven with care. Price: \$4,000. Call (201) 543-2278.

1966 Mustang fastback, with GT options, Emberglo with 225 HP engine, AT, PS, AC, console, rally pac, disc brakes, styled steel wheels, Pony interior (Parchment with Emberglo appointments), red line tires, MCA Grand Natinal winner in 1989 (street driven second place). Price: \$13,950. Contact Larry Machacek, P.O. Box 515, Porter, TX 77365, (713) 572-2505.

Parts For Sale

1969-70 Boss 302 carburetor, new, in box, \$385. 1967 fastback quarters with wheel houses (1/4 of car), good, \$125. 1967-68 windshield (tinted) CP/FBK, \$100. 1967-68 fastback rear window, \$125. 1967-68 fastback trunk lid, complete, \$150. 1970 Mach I hood/grill, \$50 each. 1969-70 big block chrome valve covers, one rechromed, \$175, 1 new (repro), \$175. Call (201) 666-8022.

For 1985-90 5.0s, Spikes-Spider for rear wheels. They attach in five minutes and can be driven up to 60 MPH. They are recommended by many Mustang publications and they don't rub against the fenders. Call Darren at (201) 599-2684 or (212) 571-4080. Have extra (4) LX rims plus other parts.

NOS Mustang II body parts: D7ZZ 6027840A quarter panel, now obsolete; D7ZZ 6027841A

THE PRICE IS RIGHT!

Mustang Times Classified Ads Are Free To All MCA Members!

WORLD CLASS BRAKING

Nearly Doubles Braking Power, Efficiency, and Control

USED BY: • High Performance Vehicles • New and Used Vehicles • Law Enforcement • Medical Service • Limousines • Utilities • Fire • RVs • Fleets • People Who Care

BRAKE GUARD IS:

- It is a Safety System with "Anti-Lock" benefits for vehicles with hydraulic brakes.
- It operates automatically, every time the brakes are applied.
- It works to inhibit wheel lock-up, skidding and loss of control when braking.
- It stops vehicles straighter and shorter with better steering control.

HOW BRAKE-GUARD WORKS:

Heat and other dimensional factors cause brake drums and discs to become slightly egg-shaped or warped. So, when the brakes are applied, the contact surfaces are correspondingly uneven. This in turn causes an unequal transmission of braking effort from the wheels to the roadway resulting in premature wheel lock-up, early brake fade, uneven wear, skidding and loss of control of vehicle.

Like a computer, Brake-Guard's patented system automatically responds to the unequal braking surfaces at each wheel, constantly metering and compensating every time the brakes are applied. The result is an even, constant pressure and uniform coefficient of friction at each wheel through the cycle of rotation, resulting in a smoother, shorter and controlled stopping of the vehicle.

Reg. Retail \$895.00 Installed

Mustang Club Special!

\$499⁰⁰ You Install



Copyright 1990



BRAKE-GUARD PRODUCTS, INC.
P.O. Box 9880 • Spokane, Washington 99209-9880
Phone (509) 325-5599 • Fax (509) 328-7251



CLASSIFIED ADS

quarter panel, now obsolete; D7ZZ 16006A front fender, \$650 plus shipping. Contact Anthony Dilabio, RR 3, Metcalfe, Ontario, Canada K0A 2P0. Phone (613) 821-1012 evenings after 7 EST or Ross Saunders (613) 224-2085. Keep trying!

NOS 1964-68 heater assembly in box. Also fits Falcon, \$350. NOS PS pump assembly/brackets for 289 engine, \$350. Consoles, AC units, some hard to find parts on hand all the time. Send list. Dan Coakley, 1724 Blomington, Kingsport, TN 37660. Phone (615) 288-8488.

1975 Cobra II stripes, NOS (Blue) sides, \$120. Fender Cobras, \$12. Hood/cowl stripes, \$100. Dave Shanahan, P.O. Box 711, Great Barrington, MA 01230. (413) 637-1017.

1970 Boss body, incomplete, rusty but restorable. Complete numbers, \$1950. Also, 1973 Grande 351C, PS, PB, AC, good car. Price: \$2,000. Call (404) 394-1279.

1967 GT350 parts: Hi-Po cam and solid lifters, hoses, belts, with washer box and pump, E70-15 Speedway tire, Kelsey-Hayes MagStar wheel (15X7), build sheets for undercarriage color codes, gas tank, bumpers, hood pin latch set. H. Hooper, 8817 Bridlewood Drive, Huntsville, AL 35802. Call (205) 883-2948.

NOS 1969 AM radio from radio kit, no knobs, \$35. D1ZZ-16C726-7 pr NOS hoodpin mounting brackets, fits Boss, \$125. S1MS-16224C white Shelby stripe kit in box, one side only, \$28. C5ZZ-17B876A RH bumper guard bracket, \$10. Used 1967-68 instrument cluster, 6000 RPM tach, trip od, no clock, \$150. NOS Autolite PCV valve in box with tag C70Z-6A666a 69 Boss 302, 67 390, \$18. NOS C6ZZ-18978A blk speaker grille in box, \$60. D1ZZ-6523942A1E red std door panel, NOS, \$80. C6ZZ-7017A B Warner 4-speed input shift NOS, \$75. C8ZZ-18817D console radio knobs, NOS in box, \$50. Sorenson, 19 Lisa Lane, Methuen, MA 01844, (508) 689-9600. Price plus actual shipping.

Cars Wanted

1986-90 5.0L HO Mustang with five-speed. Wreck preferred, as the drivetrain and wiring will be transplanted into a Turbo Coupe. Call Shawn Evans at (404) 498-7484.

Parts Wanted

429 S/CJ heads (fresh). 428 S/CJ heads (EC). 351C quench 4-barrel heads, 427 LR 2X4 aluminum intake, 428 police interceptor aluminum intake, 1969 Boss 302 balancer and NOS hose, Boss 351 dominator intake (D1ZX-prototype). Wanted: Boss 429 anything. Call (708) 448-6782.

Wanted: Circuit diagram for 1965 Philco AM radio. Harvey Lester, 3990 Aiken Road, Pensacola, FL 32503.

Miscellaneous

Original Mustang literature: sales literature, manuals, factory photos, etc. for all Mustangs. Specify year(s) with stamped envelope for free list. Be sure to specify Mustang as I have lists for all other cars and trucks, domestic and foreign. Walter Miller, 6710 Brooklawn Pkwy, Syracuse, NY 13211. Phone (315) 432-8282.

For Sale: Mustang Times, 1984-89, Hot Rod Mustang and Mustang Monthly, 1978-90; Mustang News. Also, 1968 Shelby GT 350/500 sales literature. 1973-74-75-82 Mustang Club catalogs. Ford 8X10 photos. 1967 Mustang convertible photos from new department. 1984 20th Anniversary edition buttons and news photos, kit. 1984 Ford trim upholstery loose leaf binder with Mustang SVO. Contact Charles Tickner, 4225 East Ridge Drive, Mason, MS or call (601) 366-2508.

Restoration, modification, maintenance, detailing, etc. by 20 year veteran. Ex-Ford dealer technician. Highest quality workmanship. Contact Dave Shanahan, P.O. Box 711, Great Barrington, MA 01230 or call (413) 637-1017.

New! 1965 Mustang cast metal bank, coupe or fastback. Please specify. Price: \$14.95. 20th or 25th FoMoCo anniversary posters, \$10 each or two for \$18. Prices include shipping. Bill Koivu, 7138 Maddox Road, Lithonia, GA 30058.

Zymol Car Care Products available. Derived from 110-year-old German carriage wax formula. Each product is natural. We utilized only plant oils and their derivatives as opposed to chemicals and synthetic waxes. The BMW, Mercedes and Porsche Clubs of America members continue tout Zymol as the best car system for protecting their investments. Call us for more information. Corco West Inc., Car Care Division, 1-800-533-5743.

For Sale: Mustang sales brochures, post cards, performance catalogs, posters, 1964 1/2-1990. Send SASE for free list to Randy Church, P.O. Box 7, Baldwin, GA 30511 or call (404) 778-3413.

1991 Mustang Club of America Calendar! Collector's item. Beautiful, full color calendar featuring some of the most impressive Mustangs in the nation. Price is \$8.50, which includes postage and handling. Send check or money order to MCA Calendar, P.O. Box 447, Lithonia, GA 30058.

Mustang carburetors rebuilt. Show quality. Set to specs. Better than new to overcome inherent driveability problems. Complete with new car-

buretor tag. One and two barrel specialists. Send us yours to rebuild or buy ours. Pony Carburetors, Box 420, Cazenovia, NY 13035, (315) 655-4466.

Quartz! \$64.95 updates most Mustang clocks to quartz. Includes 15 month warranty. We also repair tachs, gauges, speedometers. Instrument dial refacing and complete 1965-66 rally pac renovation available. Authorized Borg Clock/Faria Tach service. Gary Herbert, 123 Fairview Road, Simpsonville, SC 29681. Phone (803) 967-7719.

Appraisals: Keeker's Automotive Appraisals can provide you with your vehicle's current market value, whether your needs are proof of value for insurance, property settlement, estate, purchase or sale. Contact Garth McNichol, candidate member, American Society of Appraisers. Appraisals by mail available. MC and Visa accepted. Call (913) 749-1888 or write 2909 Lawrence Avenue, Lawrence, KS 66047.

Tachometer, clock, speedometer, gauge and motor professionally repaired, converted, rebuilt or modernized to factory specifications and guaranteed. Call (914) 628-4866 after 6 p.m. EST.

Now your Mustang's build date code is available through the "In Search of Mustangs" project. Send \$10 for each, including a self-addressed, stamped envelope and your Mustang's serial number. We will send your build date based on statistical information in our census. Contact P.O. Box 727, Paris, TN 38242 or call (901) 642-0010.

Now Available
MCA's Official
Judging Rule Book
\$3.00

Send Check
or
Money Order
to

MCA Accessories
P.O. Box 447
Lithonia, GA
30058-0447

